

Effective December 6, 2006, this report has been made publicly available in accordance with Section 734.3(b)(3) and published in accordance with Section 734.7 of the U.S. Export Administration Regulations. As a result of this publication, this report is subject to only copyright protection and does not require any license agreement from EPRI. This notice supersedes the export control restrictions and any proprietary licensed material notices embedded in the document prior to publication.

Air-Operated Valve Maintenance Guide



SINGLE USER LICENSE AGREEMENT

THIS IS A LEGALLY BINDING AGREEMENT BETWEEN YOU AND THE ELECTRIC POWER RESEARCH INSTITUTE (EPRI). PLEASE READ IT CAREFULLY BEFORE REMOVING THE WRAPPING MATERIAL. THIS AGREEMENT CONTINUES ON THE BACK COVER.

BY OPENING THIS SEALED REPORT YOU ARE AGREEING TO THE TERMS OF THIS AGREEMENT. IF YOU DO NOT AGREE TO THE TERMS OF THIS AGREEMENT, PROMPTLY RETURN THE UNOPENED REPORT TO EPRI AND THE PURCHASE PRICE WILL BE REFUNDED.

1. GRANT OF LICENSE

EPRI grants you the nonexclusive and nontransferable right during the term of this agreement to use this report only for your own benefit and the benefit of your organization. This means that the following may use this report: (I) your company (at any site owned or operated by your company); (II) its subsidiaries or other related entities; and (III) a consultant to your company or related entities, if the consultant has entered into a contract agreeing not to disclose the report outside of its organization or to use the report for its own benefit or the benefit of any party other than your company.

This shrink-wrap license agreement is subordinate to the terms of the Master Utility License Agreement between most U.S. EPRI member utilities and EPRI. Any EPRI member utility that does not have a Master Utility License Agreement may get one on request.

2. COPYRIGHT

This report, including the information contained in it, is owned by EPRI and is protected by United States and international copyright laws. You may not, without the prior written permission of EPRI, reproduce, translate or modify this report, in any form, in whole or in part, or prepare any derivative work based on this report.

3. RESTRICTIONS

You may not rent, lease, license, disclose or give this report to any person or organization, or use the information contained in this report, for the benefit of any third party or for any purpose other than as specified above unless such use is with the prior written permission of EPRI. You agree to take all reasonable steps to prevent unauthorized disclosure or use of this report. Except as specified above, this agreement does not grant you any right to patents, copyrights, trade secrets, trade names, trademarks or any other intellectual property, rights or licenses in respect of this report.

(continued on back cover)

Air-Operated Valve Maintenance Guide

Air-operated valves (AOVs) are used extensively in the power generation industry for process-control and system-isolation functions. This guide provides methods for establishing predictive and preventive maintenance programs for AOVs. It suggests techniques for reducing failure rates and discusses proven repair methods that can help utilities reduce downtime and unplanned outages.

INTEREST CATEGORIES

Nuclear plant operations
and maintenance
Engineering and technical
support
Maintenance practices
Nuclear component
reliability

KEYWORDS

Valves
Control equipment
Maintenance
Predictive maintenance
Preventive maintenance

BACKGROUND An increased awareness of AOV importance at nuclear power plants has led to progressively more sophisticated maintenance practices within the nuclear industry. Non-nuclear plants are also heavily dependent on reliable AOV operation. The dynamic method used by fossil power plants to satisfy transient electrical demands places additional stress on plant components, including AOVs. Therefore, there is a growing need for standardized technical guidance related to AOVs.

OBJECTIVES To research degradation modes for AOVs and to provide guidance for a practical and cost-effective AOV maintenance program that will address these degradation modes.

APPROACH EPRI's Nuclear Maintenance Applications Center (NMAC) gathered information on maintenance techniques by visiting numerous power plant maintenance department personnel. Failure data were gathered using the Institute of Nuclear Power Operation's Nuclear Plant Reliability Data System reports on AOV failures for all plants in the database. This research provided data to support maintenance program recommendations.

RESULTS This guide discusses air-operated valves (AOVs) and common accessories. Diagrams indicating the application and operation of various types of actuators are presented as an aid for thorough investigation of malfunctioning equipment. Recent developments in diagnostic equipment for AOVs are covered, and valve traces on valves with maintenance-related problems are used to demonstrate how the diagnostic equipment can quickly solve complex valve problems.

The guide includes a troubleshooting section with tables that provide easily accessible information to minimize troubleshooting costs. A detailed discussion on diaphragms that provides guidance for selecting, installing, and maintaining AOV diaphragms is furnished. Appendixes augment the guide by providing a glossary of terms and various engineering schedules, including useful engineering parameters for the proper maintenance of AOVs and accessories.

EPRI PERSPECTIVE Power plants rely on AOVs for the proper operation of many plant systems. AOVs are used extensively on both large- and small-bore piping systems and heating, ventilating, and air-conditioning (HVAC) ducting to provide isolation and flow control functions. Process applications include water, steam, N₂, H₂, and air. Predictive and preventive maintenance is one of the key ways to enhance AOV performance and subsequently reduce AOV failure rates. Through the proper implementation of key AOV maintenance activities, utilities can realize significant savings. This guide will help power plant professionals take the most effective and appropriate maintenance actions.

Related EPRI research includes reports NP-7079, *Instrument Air Guide*, and NP-7414, *Solenoid Valve Maintenance and Application Guide*.

PROJECT

WO# 3814-17

EPRI Project Manager: Kenneth F. Barry

Nuclear Maintenance Applications Center

Nuclear Power Group

Contractor: Marriott Valve Services

Altran Materials Engineering, Inc.

For further information on EPRI research programs, call EPRI Technical Information Specialists at 415/855-2411.

Air-Operated Valve Maintenance Guide

NP-7412R1
Work Order 3814-17

Final Report
November 1996

Prepared by

Revision 0
STANLEY E. PRECKWINKLE

Revision 1
MARRIOTT VALVE SERVICES
Fran McDonald
William Marriott

ALTRAN MATERIALS ENGINEERING, INC.
Joseph Groeger
Leslie Compton

Prepared for
NUCLEAR MAINTENANCE APPLICATIONS CENTER
1300 W.T. Harris Boulevard
Charlotte, NC 28262

Operated by
Electric Power Research Institute
3412 Hillview Avenue
Palo Alto, California 94304

EPRI Project Manager
Kenneth F. Barry
Nuclear Power Group

DISCLAIMER OF WARRANTIES AND LIMITATION OF LIABILITIES

THIS REPORT WAS PREPARED BY THE ORGANIZATION(S) NAMED BELOW AS AN ACCOUNT OF WORK SPONSORED OR COSPONSORED BY THE ELECTRIC POWER RESEARCH INSTITUTE, INC. (EPRI). NEITHER EPRI, ANY MEMBER OF EPRI, ANY COSPONSOR, THE ORGANIZATION(S) BELOW, NOR ANY PERSON ACTING ON BEHALF OF ANY OF THEM:

A) MAKES ANY WARRANTY OR REPRESENTATION WHATSOEVER, EXPRESS OR IMPLIED, (I) WITH RESPECT TO THE USE OF ANY INFORMATION, APPARATUS, METHOD, PROCESS, OR SIMILAR ITEM DISCLOSED IN THIS REPORT, INCLUDING MERCHANTABILITY AND FITNESS FOR A PARTICULAR PURPOSE, OR (II) THAT SUCH USE DOES NOT INFRINGE ON OR INTERFERE WITH PRIVATELY OWNED RIGHTS, INCLUDING ANY PARTY'S INTELLECTUAL PROPERTY, OR (III) THAT THIS REPORT IS SUITABLE TO ANY PARTICULAR USER'S CIRCUMSTANCE; OR

(B) ASSUMES RESPONSIBILITY FOR ANY DAMAGES OR OTHER LIABILITY WHATSOEVER (INCLUDING ANY CONSEQUENTIAL DAMAGES, EVEN IF EPRI OR ANY EPRI REPRESENTATIVE HAS BEEN ADVISED OF THE POSSIBILITY OF SUCH DAMAGES) RESULTING FROM YOUR SELECTION OR USE OF THIS REPORT OR ANY INFORMATION, APPARATUS, METHOD, PROCESS, OR SIMILAR ITEM DISCLOSED IN THIS REPORT.

ORGANIZATION(S) THAT PREPARED THIS REPORT

Marriott Valve Services
Altran Materials Engineering, Inc.

ORDERING INFORMATION

Price: (\$10,000)

Requests for copies of this report should be directed to the Nuclear Maintenance Applications Center (NMAC), 1300 Harris Boulevard, Charlotte, NC 28262, 800/356-7448. There is no charge for reports requested by NMAC member utilities.

Electric Power Research Institute and EPRI are registered service marks of Electric Power Research Institute, Inc. Copyright © 1996 Electric Power Research Institute, Inc. All rights reserved.

ABSTRACT

Air-operated valves (AOVs) are used extensively in the power generation industry for process-control and system-isolation functions. Their proper operation is essential to reliable power plant operation.

This guide discusses major components such as actuators, valves, and positioners, and explains the inter-relationship of these components. Diagrams indicating the application and operation of various types of actuators are presented as an aid for thorough investigation of malfunctioning equipment. Recent developments on diagnostic equipment for AOVs are covered and valve traces on valves with maintenance related problems are used to demonstrate how the diagnostic equipment can quickly solve complex valve problems. In addition, predictive and preventive maintenance recommendations based on specific failure data are included.

The guide also includes a troubleshooting section with tables providing easily accessible information to minimize troubleshooting costs. Appendixes augment the guide by providing a glossary of terms and various engineering schedules, including useful engineering parameters for the proper maintenance of air-operated valves and accessories.

ACKNOWLEDGMENTS

This guide was prepared for the Nuclear Maintenance Applications Center (NMAC), under the Electric Power Research Institute (EPRI) project number 2814-45. Revision 1 was developed under work order number 3814-17. In any document of this scope, numerous individuals and organizations provide extensive assistance and information to make the publication possible. We would like to acknowledge the assistance provided by Fisher Controls International, Inc.; Anchor Darling Valve Company, and Asea Brown Boveri/Combustion Engineering (ABB/CE) in granting us permission to reproduce illustrations and other information from their equipment manuals.

NMAC particularly recognizes the Air Operated Valve Users Group (AUG) and the following individuals for their valuable contributions through thorough reviews and comments. Time and attention provided by each is greatly appreciated.

Mark D. Adams - Waterford 3
Mike Alexander - Oconnee
Gayle Barb - Anchor Darling
Ralph Barfield - Vermont Yankee
Richard Boyd - Southern Nuclear
Bob Fetterman - Copes-Vulcan
Bill Fitzgerald - Fisher Controls
Steve Fuller - Fisher Services Company
John Kelly - Vectra
Doug Koons - Clinton
Bill Loomis - Vermont Yankee
Bradley A. Merkel - Technicon Enterprises, Inc.
Timothy L. Messer - Sequoyah
Dave McKibbin - Vectra
Kevin McLeod - Bruce A
Raymond W. Rosten - Vectra
L. D. Stricker - Palo Verde
Frank Szanyi - Salem
John Thielmann - Palisades
Jack Walsh - ABB Combustion Engineering
Len Zucker - Pickering

TABLE OF CONTENTS

SECTION NO.	PAGE NO.
1.0 INTRODUCTION	1-1
1.1 BACKGROUND	1-1
1.2 GUIDE SUMMARY	1-1
2.0 TECHNICAL DESCRIPTIONS	2-1
2.1 INTRODUCTION	2-1
2.2 ACTUATORS	2-1
2.2.1 Introduction	2-1
2.2.2 Spring and Diaphragm Actuators	2-7
2.2.3 Piston Actuators	2-9
2.2.4 Rotary Shaft Piston Actuators	2-11
2.3 POSITIONERS	2-12
2.3.1 Introduction	2-12
2.3.2 Positioner Applications	2-14
2.3.3 Split-Ranging	2-15
2.3.4 Positioner Operation	2-15
2.4 TRANSDUCERS	2-20
2.5 PRESSURE BOOSTER	2-21
2.6 VOLUME BOOSTER	2-22
3.0 FAILURE MODE ANALYSIS	3-1
3.1 INTRODUCTION	3-1
3.2 NPRDS DATA	3-2
3.2.1 Failures by System	3-2
3.2.2 Detailed Sub-Component Failure Analysis	3-6
3.3 CAUTIONS AND CONCERNS	3-7
3.4 SUMMARY	3-8
4.0 TROUBLESHOOTING AND RECOMMENDED CORRECTIVE MAINTENANCE PRACTICES ...	4-1
4.1 TROUBLESHOOTING GUIDELINES	4-1
4.1.1 Control Valve Problems	4-1
4.1.2 Actuator Problems	4-7
4.1.3 E/P OR I/P Transducer Problems	4-11
4.1.4 Positioner Problems	4-12
4.1.5 Volume Booster Problems	4-13

SECTION NO.	PAGE NO.
4.2 MAINTENANCE PHILOSOPHY	4-13
4.2.1 A Holistic Approach	4-13
4.3 PRE-OUTAGE WORK	4-14
4.3.1 Preparation	4-14
4.3.2 Walkdown	4-15
4.3.3 Ordering Parts	4-15
4.3.4 Information Gathering	4-16
4.3.5 Notification (Scheduling)	4-17
4.3.6 The Checklist (Tickler)	4-18
4.4 CORRECTIVE MAINTENANCE TASKS	4-18
4.4.1 General Discussion	4-18
4.4.2 Starting the Job (Helpful Hints)	4-19
4.4.3 Rigging Out/In	4-20
4.4.4 Disassembly and Inspection	4-20
4.4.5 Actuator Maintenance	4-22
4.4.6 E/P or I/P Transducer Maintenance	4-24
4.4.7 Positioner Maintenance	4-25
4.4.8 Volume Booster Maintenance	4-26
4.4.9 Close Out	4-26
5.0 PREVENTIVE MAINTENANCE	5-1
5.1 Introduction	5-1
5.2 AOV PM Template	5-2
5.3 Template Notes	5-3
NOTE 1: Use of Template Intervals	5-3
NOTE 2: Service Conditions	5-3
NOTE 3: Run-To-Failure	5-3
NOTE 4: Post-Maintenance Test	5-3
NOTE 5: Regulatory Requirements	5-4
NOTE 6: Scheduling of Related Tasks	5-4
NOTE 7: Scheduling for Related Components	5-4
5.4 PM Rationale and Content:	5-4
5.4.1 Calibration of Accessories	5-4
5.4.2 Packing—Inspection and Adjustment	5-5
5.4.3 Visual External Inspection	5-5
5.4.4 Diagnostic Scan	5-6
5.4.5 Internal Leak Detection	5-7
5.4.6 Ultrasonic Techniques—Minimum Wall Thickness	5-8
5.4.7 Air Supply Filter Replacement	5-8
5.4.8 Actuator Assembly Overhaul	5-8
5.4.9 Replacement of Accessories	5-10
5.4.10 Valve Assembly Overhaul	5-11
5.4.11 Packing Replacement	5-12
5.4.12 Stroke Test—Timed Stroke, SOV, and Limit Switch Actuations	5-12
5.5 Examples of Valves Satisfying Template Conditions	5-13
5.6 Definitions of Template Application Conditions:	5-14
5.6.1 Critical	5-14
5.6.2 Duty Cycle	5-14
5.6.3 Service Condition	5-14

SECTION NO.	PAGE NO.
6.0 DATA ACQUISITION AND DIAGNOSTICS	6-1
6.1 INTRODUCTION	6-1
6.2 MANUAL CALIBRATION VERSUS DATA ACQUISITION SYSTEM CALIBRATION	6-2
6.3 DATA ACQUISITION SYSTEM OPERATION	6-3
6.3.1 Parameters To Be Measured	6-3
6.3.2 Testing Sequence	6-5
6.4 GRAPHICAL ANALYSIS	6-6
6.4.1 Evaluation from Step Open and Step Closed Testing	6-7
6.4.2 Evaluation from Slow Ramp Testing	6-10
6.5 PLANT SYSTEM APPLICATION	6-20
6.6 OUTAGE PLANNING	6-20
6.7 PREDICTIVE MAINTENANCE	6-21
6.8 DATA ACQUISITION SYSTEM BENEFITS	6-21
6.8.1 Reduced Maintenance Expense	6-21
6.8.2 Reduced Downtime	6-21
6.8.3 Improved Process Efficiency	6-21
6.8.4 Improved Safety	6-21
6.8.5 Improved Training	6-22
6.8.6 General Benefits	6-22
7.0 DIAPHRAGMS	7-1
7.1 INTRODUCTION AND BACKGROUND	7-1
7.2 DIAPHRAGM SELECTION	7-2
7.2.1 Compounding	7-2
7.2.2 Molding	7-9
7.2.3 Crosslinking	7-11
7.2.4 Rubber Options	7-12
7.2.5 Fiber Options	7-13
7.2.6 Service Conditions	7-16
7.2.7 New Diaphragm Inspection	7-17
7.3 PACKAGING AND HANDLING	7-17
7.3.1 Packaging Considerations	7-18
7.3.2 Environmental Considerations	7-18
7.4 INSTALLATION	7-19
7.4.1 Cleaning	7-19
7.4.2 Clamping	7-20
7.4.3 Bolt Holes	7-20
7.4.4 Lubrication	7-22
7.4.5 Valve Housing Considerations	7-22
7.5 MAINTENANCE	7-23
7.5.1 Inservice Inspection	7-23
7.5.2 Cleaning	7-26
7.6 FAILURE ANALYSIS	7-26
7.6.1 Evidence Preservation	7-26
7.6.2 Test Methods	7-27
7.6.3 Interpretation	7-38

SECTION NO.	PAGE NO.
7.7 POTENTIAL FAILURE MECHANISMS	7-40
7.7.1 Mechanical Rupture	7-40
7.7.2 Compression Damage	7-43
7.7.3 Solvent Exposure	7-46
7.7.4 Lubricant Interaction	7-48
7.7.5 Thermal Degradation	7-48
7.7.6 Delamination	7-51
7.8 LUBRICANT INTERACTION WITH POLYMERIC COMPONENTS	7-51
7.8.1 Common Lubricants in Plant Applications	7-52
7.8.2 Degradation Mechanisms	7-52
7.8.3 Polymer/Lubricant Compatibility Screening Tests	7-53
7.8.4 Physical Considerations	7-55
7.8.5 Recommendations	7-55
APPENDIX A: GLOSSARY	A-1
APPENDIX B: TEST CONNECTIONS FOR DATA ACQUISITION EQUIPMENT	B-1
B.1 WHAT ARE TEST CONNECTIONS?	B-1
B.2 TYPES OF SIGNALS	B-1
B.2.1 Electrical Signals	B-1
B.2.2 Pneumatic Signals	B-2
B.3 BENEFITS OF PERMANENT TEST CONNECTIONS	B-3
B.4 LOCATION OF THE PNEUMATIC TEST TEES	B-4
B.5 GENERIC PROCEDURE FOR INSTALLING QUICK DISCONNECTS	B-5
APPENDIX C: AOV ACQUISITION SYSTEM CASE HISTORIES	C-1
C.1 INTRODUCTION	C-1
C.2 SUPPLY PROBLEMS	C-1
Case 1	C-1
Case 2	C-4
C.3 TRANSDUCER PROBLEMS	C-5
Case 1	C-5
Case 2	C-6
Case 3	C-7
C.4 POSITIONER PROBLEMS	C-8
Case 1	C-8
Case 2	C-9
Case 3	C-12
Case 4	C-14
C.5 VALVE PROBLEMS	C-16
Case 1	C-16
Case 2	C-18
Case 3	C-19
Case 4	C-20
Case 5	C-21
Case 6	C-22

SECTION NO.	PAGE NO.
C.6 ACTUATOR PROBLEMS	C-23
Actuator Leak—Stem Seal	C-23
C.7 MISCELLANEOUS PROBLEMS	C-24
Pilot-Operated SOV	C-24
APPENDIX D1: ACTUATOR SELECTION	D1-1
ABSTRACT	D1-1
Actuator Selection	D1-1
Conclusions	D1-8
Equations	D1-8
BIBLIOGRAPHY	D1-11
APPENDIX D2	D2-1
D2.1 EXAMPLE	D2-1
D2.2 COMBINATION	D2-1
D2.3 APPENDIX “D2” EXAMPLE INPUT DATA	D2-2
D2.4 FREE BODY DIAGRAM	D2-2
D2.5 FORCE RESULTS	D2-3
D2.5.1 Referenced Equation BE 4	D2-3
D2.6 ACTUATOR PRESSURE CONDITIONS	D2-4
D2.7 SHUT-OFF CONDITON PRESSURE	D2-5
D2.8 REFERENCED DEFINITIONS	D2-5
APPENDIX E: PERIODIC TESTING METHODS FOR SAFETY-RELATED AIR-OPERATED VALVES	E-1
PURPOSE	E-1
DISCLAIMER	E-1
BACKGROUND	E-1
REQUIREMENTS OF THE GUIDE	E-1
Preservice Testing	E-1
Periodic Valve Stroke Test	E-4
METHODS OF TESTING	E-4
APPENDIX F: GENERAL PROPERTIES OF ELASTOMERS	F-1
APPENDIX G: PROPERTIES OF PLASTICS AND ELASTOMERS USED IN VALVES FOR SOFT SEATS, SEALS, AND GASKETS	G-1

SECTION NO.	PAGE NO.
APPENDIX H: RADIATION RESISTANCE OF PLASTICS	H-1
Group 1	H-1
Plastics retaining satisfactory properties after exposure to 10(10) rads	H-1
Group 2	H-1
Plastics retaining satisfactory properties after exposure to 10(9) rads	H-1
Group 3	H-2
Plastics retaining satisfactory properties after exposure to 10(8) rads	H-2
Group 4	H-2
Plastics retaining satisfactory properties after exposure to 10(7) rads	H-2
Group 5	H-3
Plastics retaining satisfactory properties after exposure to 10(6) rads	H-3
Group 6	H-3
Plastics retaining satisfactory properties after exposure to 10(5) rads	H-3
APPENDIX I: SAMPLE VALVE DATA SHEET	I-1
Plant Information	I-1
Equipment Information	I-1
Parts Information	I-1
Attach	I-1
Scheduling Information	I-1
APPENDIX J: VALVE MAINTENANCE CLEARANCE DATA	J-1
APPENDIX K: ACTUATOR AND ACCESSORY MANUFACTURERS	K-1
APPENDIX L: BIBLIOGRAPHY	L-1

LIST OF FIGURES

FIGURE NO.	PAGE NO.
2-1	2-2
2-2	2-3
2-3	2-4
2-4	2-5
2-5	2-6
2-6	2-6
2-7	2-8
2-8	2-10
2-9	2-12
2-10	2-13
2-11	2-15
2-12	2-16
2-13	2-17
2-14	2-18
2-15	2-19
2-16	2-20
2-17	2-21
2-18	2-22
2-19	2-22
4-1	4-24
6-1	6-3

FIGURE NO.	PAGE NO.
6-2	Typical On-Off or Isolation Valve Measured Parameters 6-4
6-3	Overall Valve and Component Responsiveness 6-8
6-3A	I/P Response to Increasing Signal 6-9
6-3B	I/P Response to Decreasing Signal 6-9
6-4	Mechanical Properties of a Valve 6-10
6-4A	Enlargement Section of Figure 6-2 (Shows Distortion Due to Seating Forces) 6-12
6-5	Typical Calibration of I/P Transducer 6-15
6-5A	I/P Calibration with Linearity Considerations 6-17
6-6	Calibration of Valve Positioner 6-18
7-1	Cross-Section of Representative AOV Diaphragm, with Component Areas Identified (Not Prepared to Scale) 7-2
7-2	Comparison of Buna-N Formulations (Concentrations in PHR Resin) 7-4
7-3	Block Diagram of In-Line Kneader Type Mixer for Preparing Elastomeric Compounds 7-7
7-4	Diagram of Internal Mixer and Its Relationship to the Milling Process 7-8
7-5	Illustration of Banbury-Type Internal Mixer 7-9
7-6	Molding of Fabric-Reinforced Components 7-10
7-7	Illustration of Crosslinking Methods 7-12
7-8	Comparison of Elastomer Characteristics 7-13
7-9	SEM Photomicrograph of Buna-N Diaphragm Fiber Weave, Magnification 15x 7-14
7-10	SEM Photomicrograph of Neoprene Diaphragm Fiber Weave, Magnification 15x 7-14
7-11	SEM Photomicrograph of Silicone Rubber Diaphragm Fiber Weave, Magnification 15x 7-15
7-12	Illustration of Fiber Damage from Field Drilling of Bolt Holes 7-21
7-13	Solvent-Attacked Diaphragm, Showing the Porosity Resulting from Dissolution of the Rubber 7-33
7-14	Surface Details at a Diaphragm Tear 7-33
7-15	Surface Details at a Cut in a Diaphragm Surface 7-34
7-16	Nylon Fibers, Showing the Surface Details Resulting from Cutting Damage during Installation or Handling 7-34
7-17	Surface Details at the Torn End of Nylon Fiber, Resulting from Tensile Overload 7-35

FIGURE NO.	PAGE NO.
7-18	Location of Tensile Samples for Mechanical Testing 7-36
7-19	Load versus % Elongation for Sample from Failed Buna-N Diaphragm and Non-Used Diaphragm from the Same Manufacturing Date 7-37
7-20	Photograph of a Failed Diaphragm with a Six-Inch Rupture 7-41
7-21	Photograph of Exposed Fibers near a Bolt Hole Showing the Fiber Pull-Out 7-43
7-22	Photograph of a Severely Compressed Diaphragm, Removed from Service after Failure .. 7-44
7-23	Photograph of Bolt Holes on a Severely Compressed Diaphragm, Showing the Extrusion of Rubber between the Threads 7-45
7-24	Comparative Thickness Profile Measurements for a Diaphragm Removed from Service and a Non-Used Diaphragm 7-45
7-25	Photograph of Crazed Surface of a Section of an OV Diaphragm Removed from Service during ISI 7-48
7-26	SEM Micrograph of a Diaphragm Surface Damaged by Thermal Degradation, Showing the Texture of the Flange Surface 7-49
7-27	Illustration of Plasticizer Migration from within the Bulk Elastomer, Concentrating at the Surface Following Thermal Aging 7-50
7-28	View of Graphite-Type Lubricant Film on the Surface of an AOV Diaphragm after Drying 7-55
C-1	Before—Small Supply Tubing C-1
C-2	After—Larger Supply Tubing C-2
C-3	Results of Change C-3
C-4	48-Inch Butterfly Valve with 5/16-Inch Tubing—70 Feet plus Long C-4
C-5	As-Found C-5
C-6	After Repair C-6
C-7	Overall Calibration C-6
C-8	I/P Calibration C-7
C-9	I/P Calibration C-7
C-10	Positioner Bellows C-8
C-11	Feedwater Valve—Double-Acting Cylinder Percent of Span versus Time C-9
C-12	Feedwater Valve—Double-Acting Cylinder PSIG versus Time C-10

FIGURE NO.	PAGE NO.
C-13	Feedwater Valve—Double-Acting Cylinder PSI versus Time C-11
C-14	Feedwater Valve—Double-Acting Cylinder Overall Calibration/Control C-11
C-15	Example of No Leak C-12
C-16	Typical Air Leak Study PSIG versus Time C-13
C-17	Typical Air Leak Study PSIG versus Actuator Pressure C-13
C-18	Typical Air Leak Study PSIG versus Time C-14
C-19	Typical Air Leak Study PSIG versus Time C-15
C-20	Time in Seconds 48-Inch Butterfly Valve—Seat Problem? C-16
C-21	Exploded View of Mechanical Properties C-17
C-22	Galling Cage Mechanical Properties C-18
C-23	Excessive Coking Mechanical Properties C-19
C-24	Severe Galling Mechanical Properties C-20
C-25	Packing Leak Mechanical Properties C-21
C-26	Expanded Seating Profile Mechanical Properties C-22
C-27	Total Valve (Travel versus Signal) C-23
C-28	I/P Calibration C-24
C-29	SOV Pilot Shift Indication at 100 psig C-25
C-30	SOV Pilot Shift Indication at 60 psig C-26
C-31	SOV Pilot Shift Indication at 40 psig C-26
D1-1	Force Balance Diagram D1-2
D1-2	Closure Member Unbalanced Area D1-6
D2-1	Free Body Diagram D2-6
E-1	Combining Methods E-2

LIST OF TABLES

TABLE NO.		PAGE NO.
3-1	PWR AOV Failures by System	3-2
3-2	BWR AOV Failures by System	3-2
3-3	PWR Main Steam System Failures by Application	3-3
3-4	PWR Main Feedwater System Failures by Application	3-3
3-5	PWR Main Steam Turbine Dump Valve Failure Causes	3-4
3-6	PWR Power-Operated Relief Valve Failure Causes	3-4
3-7	PWR Main Feedwater Regulating Valve Failure Causes	3-5
3-8	BWR Main Steam System Failures by Application	3-5
3-9	BWR Main Feedwater System Failures by Application	3-5
3-10	BWR Main Steam Isolation Valve Failure Causes	3-6
3-11	BWR Main Feedwater Regulating Valve Failure Causes	3-6
3-12	Subcomponent Failure from 6/1/94 to 6/1/95	3-7
4-1	Control Valve Problems	4-6
4-2	Diaphragm Actuator Problems	4-9
4-3	Piston Actuator Problems	4-10
4-4	E/P or I/P Transducer Problems	4-11
4-5	Positioner Problems	4-12
4-6	Volume Booster Problems	4-13
6-1	Overview of Graphic Analysis	6-7
7-1	In-Service Inspection Check List	7-25
7-2	Simple Field Tests for the Initial Evaluation of AOV Diaphragms and Other Elastomeric Components	7-29

TABLE NO.		PAGE NO.
7-3	Summary of Representative AOV Soft Parts Failure Mechanisms	7-39
7-4	Sources and Types of Plant Chemicals and Solvents Potentially Harmful to Diaphragm Elastomer Materials	7-47
D1-1	Packing Friction Factors	D1-4
D1-2	Seat Load Force	D1-5
D1-3	Identification of Letter Codes	D1-6
D1-4	Summary of Force Action	D1-7
E-1	Safety Function Parameters	E-5
E-2	Comparison of Data Acquisition Methods in Support of O&M 19	E-7

1

INTRODUCTION

Power plants rely on air-operated valves (AOVs) for the proper operation of many plant systems. AOVs are used extensively on both large- and small-bore piping systems and HVAC ducting to provide isolation and flow control functions. Process applications include water, steam, nitrogen, hydrogen, and air.

1.1 BACKGROUND

Air-operated valve failures in vital systems at nuclear power plants pose many significant problems. Not only do AOV failures raise reliability concerns with the regulatory agencies because of reactor trip, shutdown, and unnecessary transients, they are also extremely expensive to the utilities due to unplanned outages and lost production revenues. Non-nuclear plants are also heavily dependent upon reliable AOV operation. The dynamic method in which fossil power plants are used to satisfy transient electrical demands places additional stress on plant components, including AOVs.

Preliminary reports indicate that these failures could be attributed to poor quality instrument air. Further investigation has provided additional information indicating that errors in maintenance and manufacturing defects might also be suspect. NMAC Publication NP-7079, *Instrument Air Guide*, addresses instrument air system problems and maintenance. This publication is designed to supplement NP-7079 by providing guidance for the maintenance of air-operated valves and accessories. The Instrument Society of America (ISA) has published standards that are also useful: Instrument Air Quality (ANSI/ISA-S7.3-1975) and Recommended Practice for Producing Quality Instrument Air (ISA-RP7.7-1984).

1.2 GUIDE SUMMARY

In the Technical Descriptions chapter, the major components of AOVs, for example, actuators and positioners, are discussed; the interrelationship of the components is explained. Diagrams indicating various types of actuators, their application, and operation are presented as an aid for thorough investigation of malfunctioning equipment.

Failure Mode Analysis is the subject of the third chapter. A majority of the information was gathered using the Institute of Nuclear Plant Operation's (INPO) Nuclear Plant

Reliability Data System (NPRDS) reports on air-operated valve failures at all plants in the database. This research provides statistical data to support maintenance program recommendations. Additional failure data was gathered through site visits.

The AOV Troubleshooting and Corrective Maintenance Recommended Practices chapter provides common symptoms of a wide range of AOV problems with their associated causes. These tables are organized in a logical order to minimize troubleshooting costs. This chapter also covers corrective maintenance tasks for the actuator and accessories.

The Preventive Maintenance Template chapter provides a program for preventive maintenance (PM) tasks suitable for application to AOVs in nuclear power plants. This template was developed under EPRI Work Order 4109 under the project management of EPRI project manager John Gisclon.

The Data Acquisition and Diagnostics chapter covers recent developments on diagnostic equipment for air-operated valves. Valve traces on valves with maintenance-related problems are used to demonstrate how the diagnostic equipment can quickly solve complex valve problems.

The Diaphragm chapter provides detailed information in diaphragm selection, packaging and handling, installation, maintenance, failure analysis, potential failure mechanisms, and lubricant interaction with polymeric components.

The appendixes augment other chapters by providing a glossary of terms and various engineering schedules, including useful engineering parameters for the proper maintenance of air-operated valves and accessories.

2

TECHNICAL DESCRIPTIONS

2.1 INTRODUCTION

Air-operated valves consist of two major components: the valve and the actuator. Accessories such as positioners can interface with both components. Valves are described in detail in EPRI document NP-6516, *Guide for the Application and Use of Valves*, currently under revision by NMAC. This section covers actuators and the primary accessories used in a standard AOV application.

2.2 ACTUATORS

2.2.1 Introduction

Pneumatic actuators are devices that modulate valve plugs and disks to control the flow through valves in response to a signal. Pneumatic actuators are manufactured in two major categories: (1) spring and diaphragm actuators and (2) piston actuators. Each category can be designed for linear or rotary valve action.

Spring and diaphragm actuators have two operational modes: direct-acting (air to extend), shown in Figure 2-1, and reverse-acting (air to retract), shown in Figure 2-2. Spring and diaphragm actuators are also available as a springless type, shown in Figure 2-3. Springless-type actuators are often used with double-acting valve positioners and can provide larger seating forces than spring-type actuators.

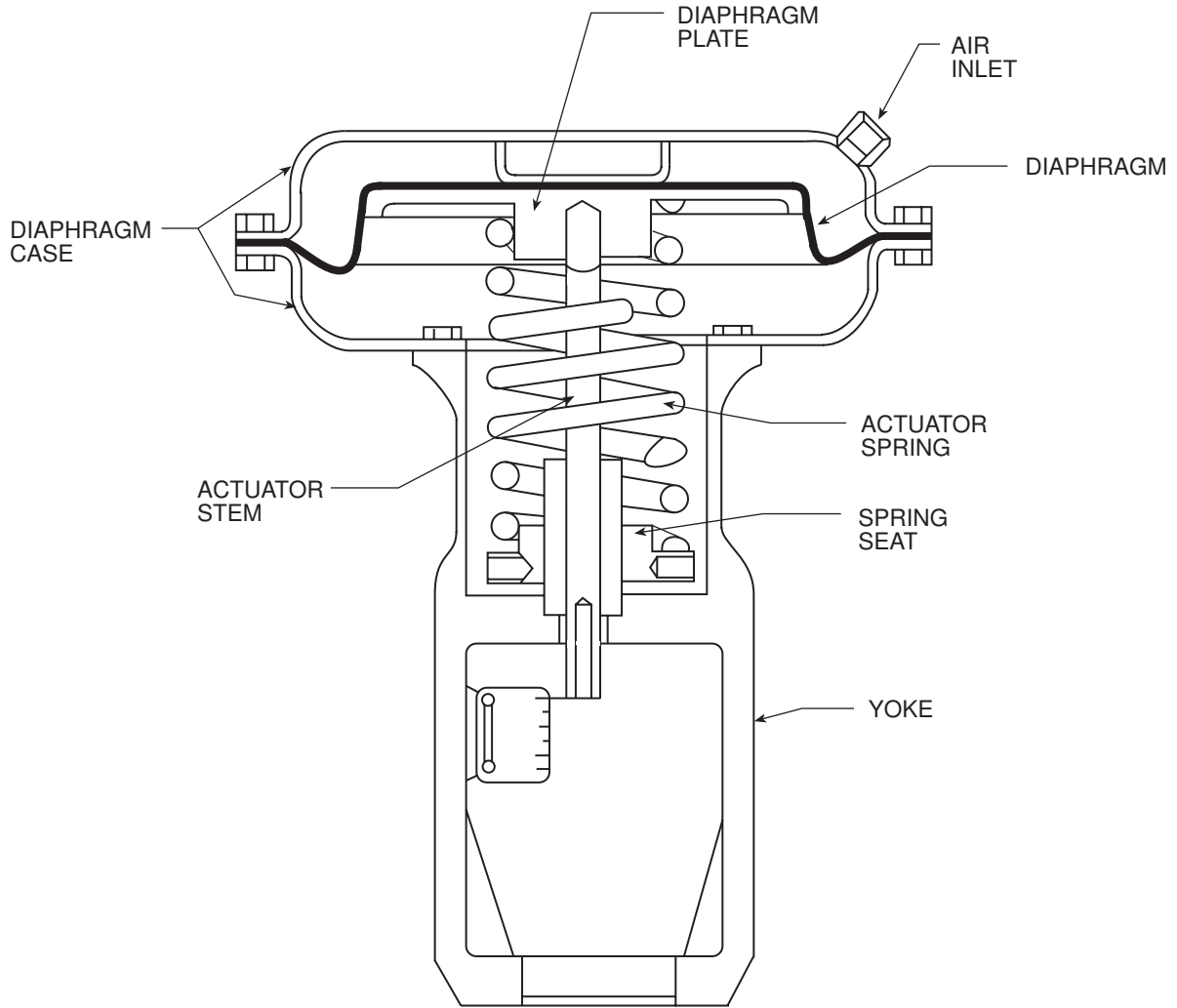

Figure 2-1
Direct-Acting Actuator

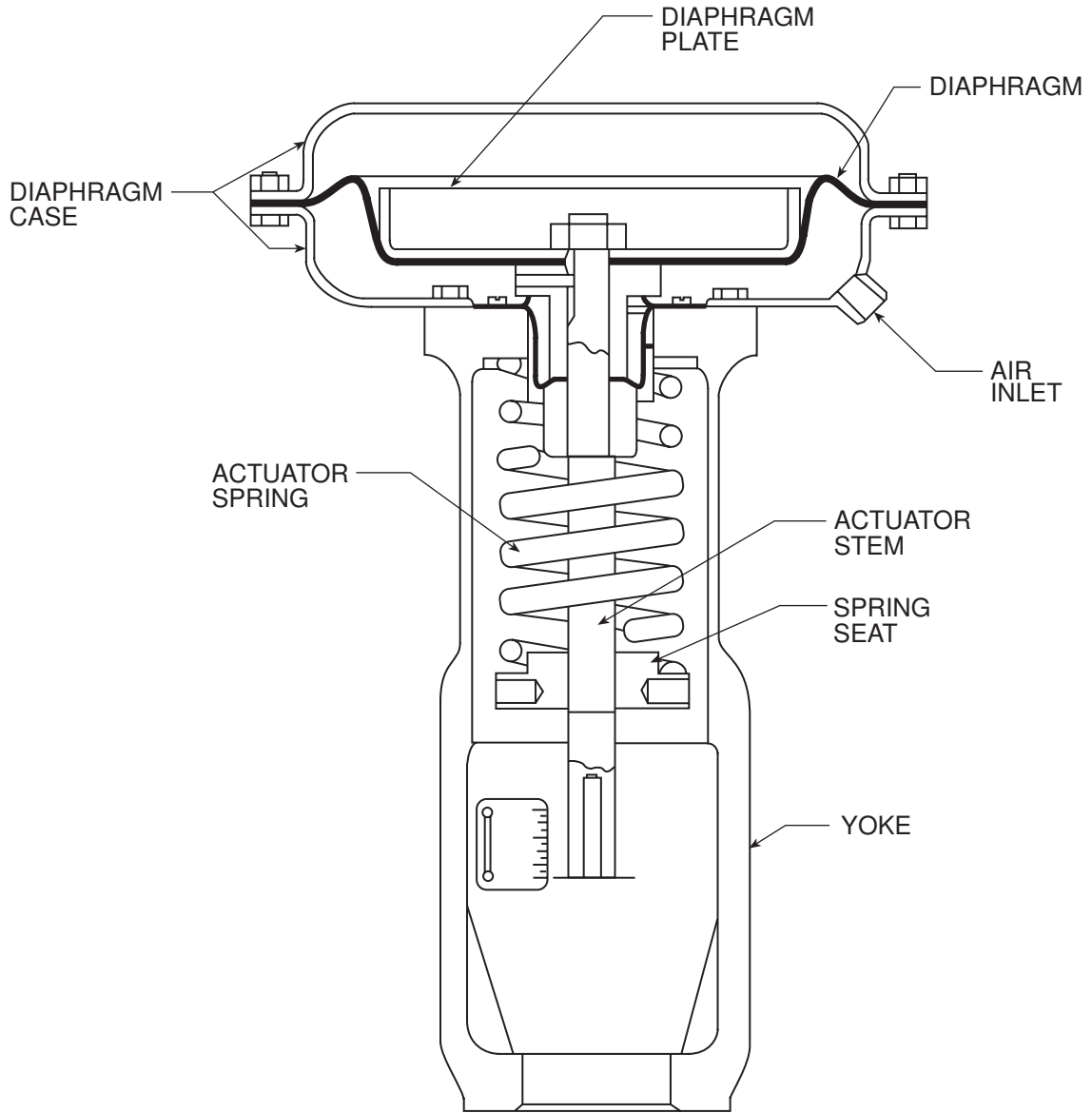

Figure 2-2
Reverse-Acting Actuator

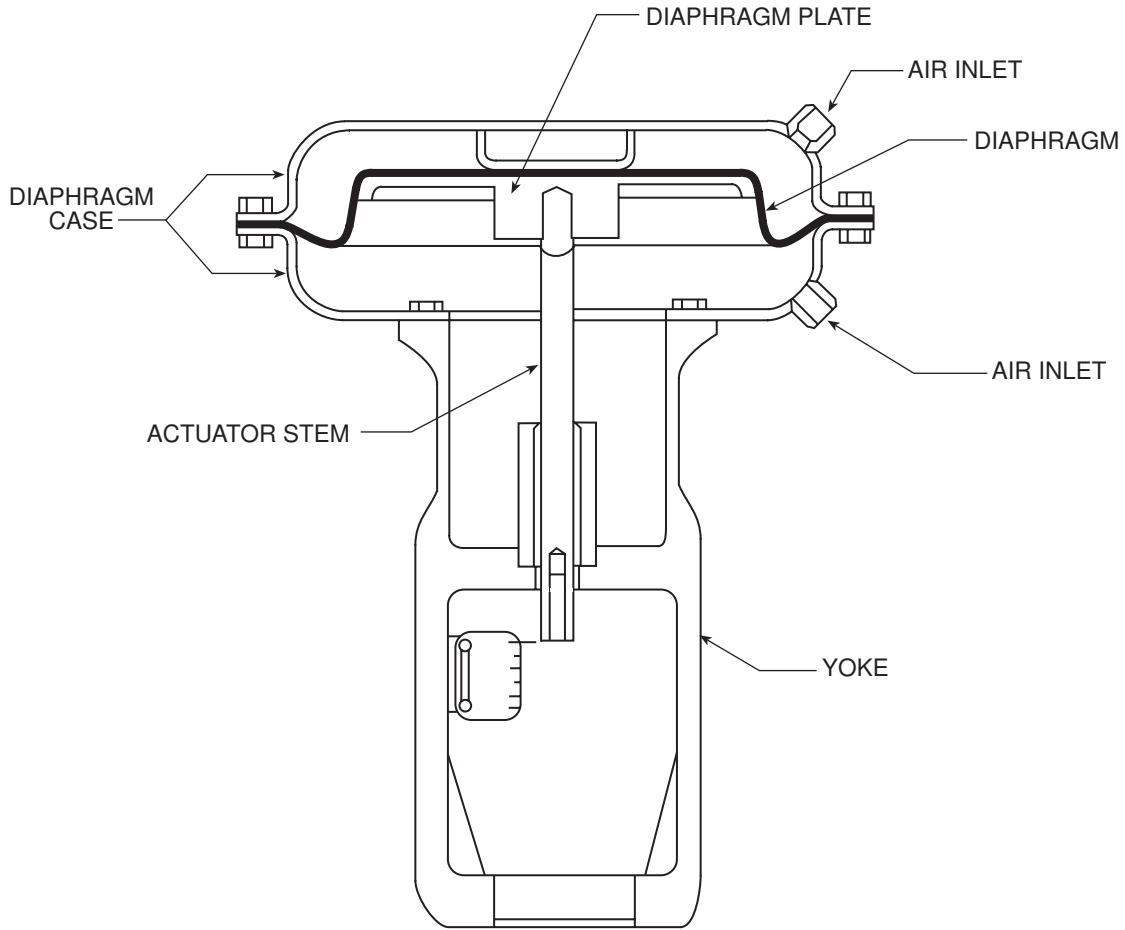

Figure 2-3
Springless-Type Actuator

Piston actuators have three operational modes: double-acting, spring-return, and spring-bias. They are available in both major constructions, linear (Figure 2-4) and rotary. Rotary constructions can use rack and pinion (Figure 2-5) or the Scotch yoke (Figure 2-6) to produce a rotary motion output.

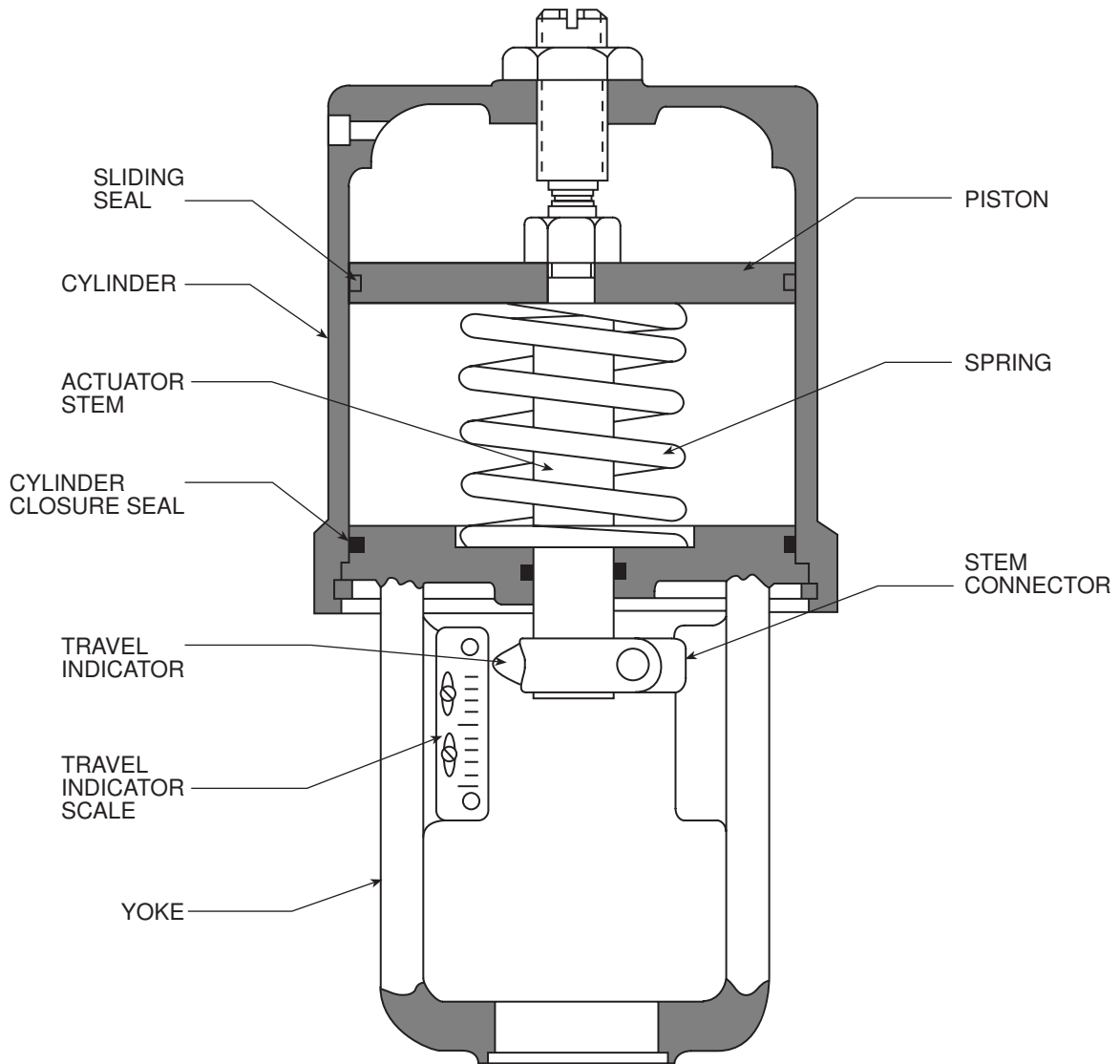

Figure 2-4
Linear Piston Actuator

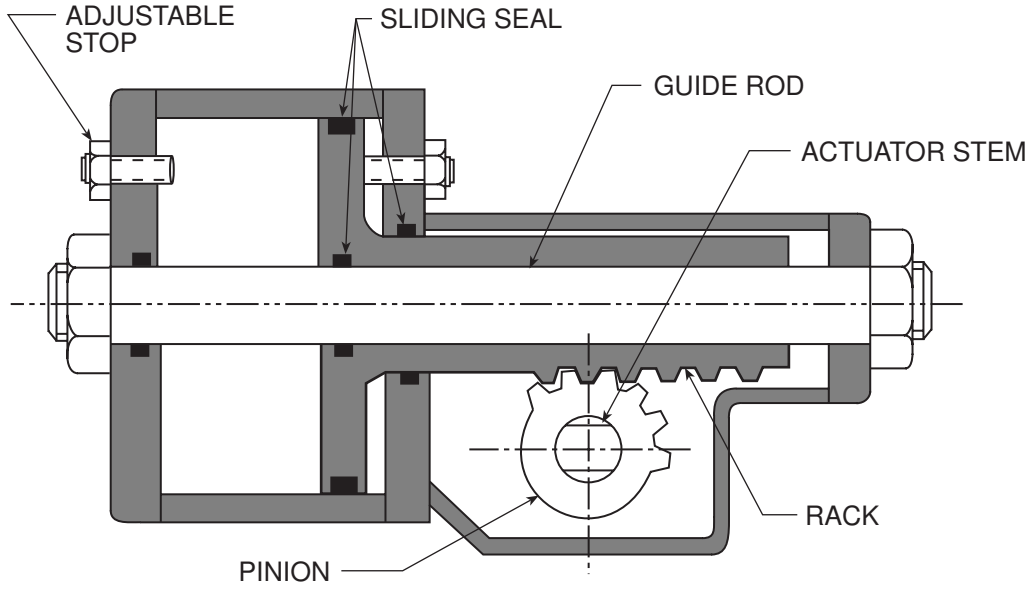

Figure 2-5
Rack and Pinion Actuator

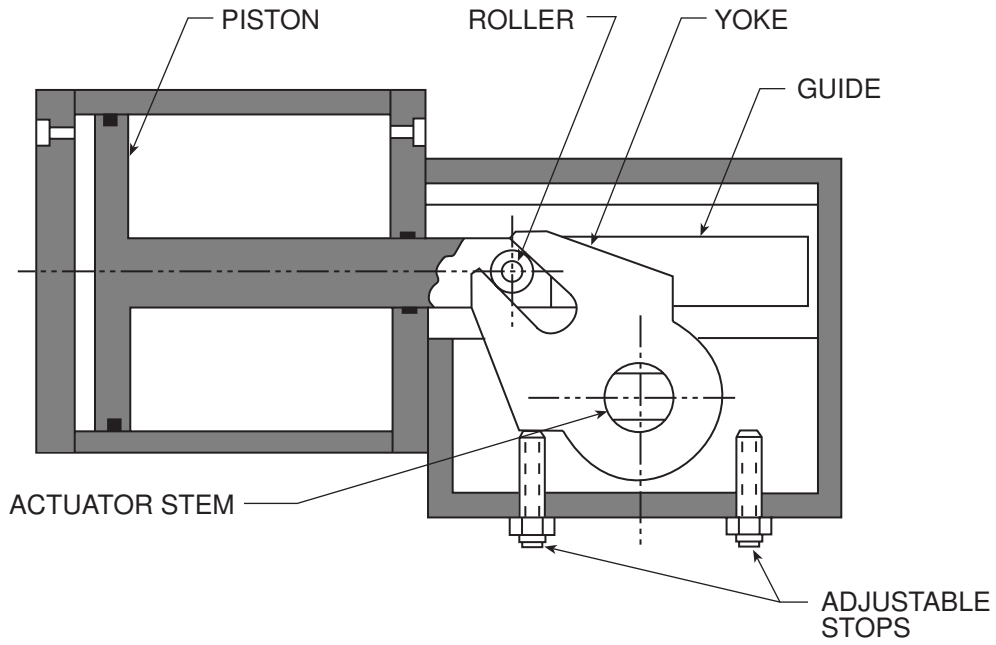

Figure 2-6
Scotch Yoke Actuator

2.2.2 Spring and Diaphragm Actuators

Pneumatically operated spring and diaphragm actuators are the most popular actuators in use today. This type of actuator is a pneumatically powered device in which the compressible medium acts upon a diaphragm to provide linear motion to the actuator stem.

AOV diagrams feature a raised center section with a flat flange edge. The overall diameter of typical diaphragms ranges from 6 inches to more than 18 inches. The flange edge is commonly 1 inch wide and the center hole is approximately 0.75 inch in diameter. In practice, the perimeter seal is established by compression of the flanges using a bolted housing. The center is sealed by use of a compression seal against flat support plates on both faces of the diaphragm.

For a direct-acting actuator (Figure 2-1), when pressure is applied to the air inlet, the actual force provided by the actuator is determined by the supply air pressure multiplied by the area of the diaphragm less the force of the actuator springs.

$$F = (Ppr^2) - S$$

Where:

F = Actuator force (lbs.)

P = Supply air pressure to the diaphragm (psig)

r = Diaphragm effective radius (inches)

S = Spring force (lbs.)

The actuator stem moves when the force supplied by the diaphragm exceeds that of the spring (friction forces of the actuator are negligible.) The actuator stem continues to move as the pressure is increased until the rated stroke is achieved. The distance that the stem moves when the actuator achieves the rated stroke is called *rated travel*. The time that the actuator takes to move the rated travel distance is called the *stroke time*. When the actuator is attached to the valve, many other forces affect the movement of the stem; these forces are covered in more detail in Appendix D1, Actuator Selection.

To move the stem in the opposite direction, the air supply pressure to the diaphragm is vented to the atmosphere and the spring force (the spring is compressed during the stroke cycle) moves the actuator back to the original position shown in Figure 2-1. The direction that the valve moves when the air supply is vented determines the failure mode of the valve. Figure 2-7 shows a fail closed valve. The valve, upon loss of air pressure, moves closed because the spring force is configured to push the valve plug into the seat.

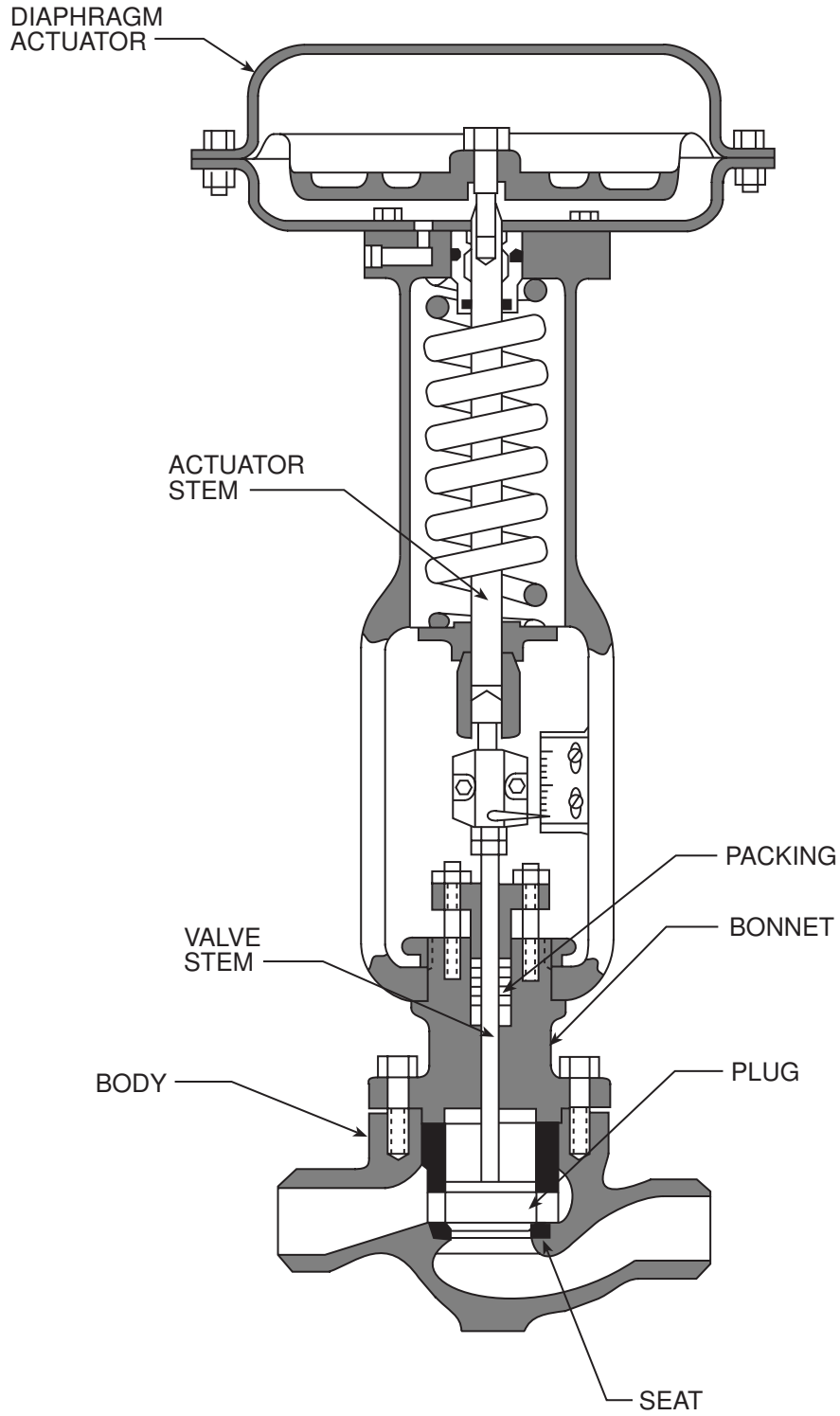

Figure 2-7
Fail Closed Control Valve

As can be observed in this simple example, the actuator provides a greater force for moving the valve if the air supply pressure is increased. Additional force is available until the air supply pressure exceeds the limiting design criteria (for example, failure of the diaphragm or actuator cases). Hence, there is an upper limit of the force that can be provided by a given diaphragm area.

A larger diameter diaphragm provides additional force due to its greater effective surface area and, hence, greater force. As the actuator size increases, its weight also increases, placing greater strain on the supporting valve and piping. The larger actuator also requires greater clearances for its installation.

For these reasons, spring and diaphragm actuators tend to be used for lower force requirements than piston actuators.

2.2.3 Piston Actuators

Piston actuators (Figures 2-4, 2-5, and 2-6) can be used to change the position of the valve plug, disk, or ball in a valve. Compared to diaphragm actuators, piston actuators exert large amounts of force for their compact size when a high-pressure air source is available, but they require a positioner for throttling. For on/off operation, a solenoid valve can be used. Piston actuators are manufactured with both sliding stem and rotary shaft configurations.

A piston actuator is a piston and cylinder assembly operated by pneumatic pressure (usually compressed air). It operates by pressure imbalance with the piston moving to the low pressure side.

Force and motion are produced by applying pressure to one side of the piston while exhausting pressure from the other. Pressure enters and exits through loading pressure connections. In double-acting and spring-bias types, two connections are used: one is always above the piston and the other always below it.

For spring-return types, a single loading pressure connection is on the side opposite the spring. The piston rod is guided by bushings in the actuator housing to provide positive alignment over the stroke; it is sealed with O-rings wherever it passes through the casing to keep cylinder pressure from escaping. Visual travel indication is provided by a travel indicator pointer and travel indicator scale, located in the yoke of a sliding stem actuator or on the side of a rotary shaft actuator housing. Travel stops, mechanical limits to travel, typically are located at the upper and lower ends of the cylinder in a double-acting actuator; in rotary actuators, they can be provided in the form of machine screws to limit lever motion.

Piston actuators other than spring return always require a positioner to control valve stem movement in throttling applications. Piston actuators also require a clean and dry air supply. Accumulated debris from dirty air can score the cylinder, damage the seals, and interfere with proper positioner operation. Moist air can deposit condensate inside the cylinder, causing corrosion and lubrication problems.

Double-acting piston actuators have air regulated to both sides of the piston. Unless modified by spring-bias, double-acting actuators (Figure 2-6) have no inherent fail mode; that is, they do not necessarily return to the open or closed position upon loss of supply pressure.

Spring-return actuators (Figure 2-4) have pressure applied to the loading side of the piston, compressing the spring on the non-loaded side. This provides an inherent fail mode. Springs can be located in the actuator cylinder or in the mounting yoke.

Spring-bias actuators (Figure 2-5) are modifications of the double-acting actuator designs. Either side of the piston can be pressurized, but a spring is added to provide a fail mode.

For on/off applications, a switching device such as a solenoid valve can be used to control the pressure sent to the actuator. A typical installation is a three-way solenoid for a diaphragm actuator or a four-way solenoid for a piston actuator. In Figure 2-8, these two installations are illustrated.

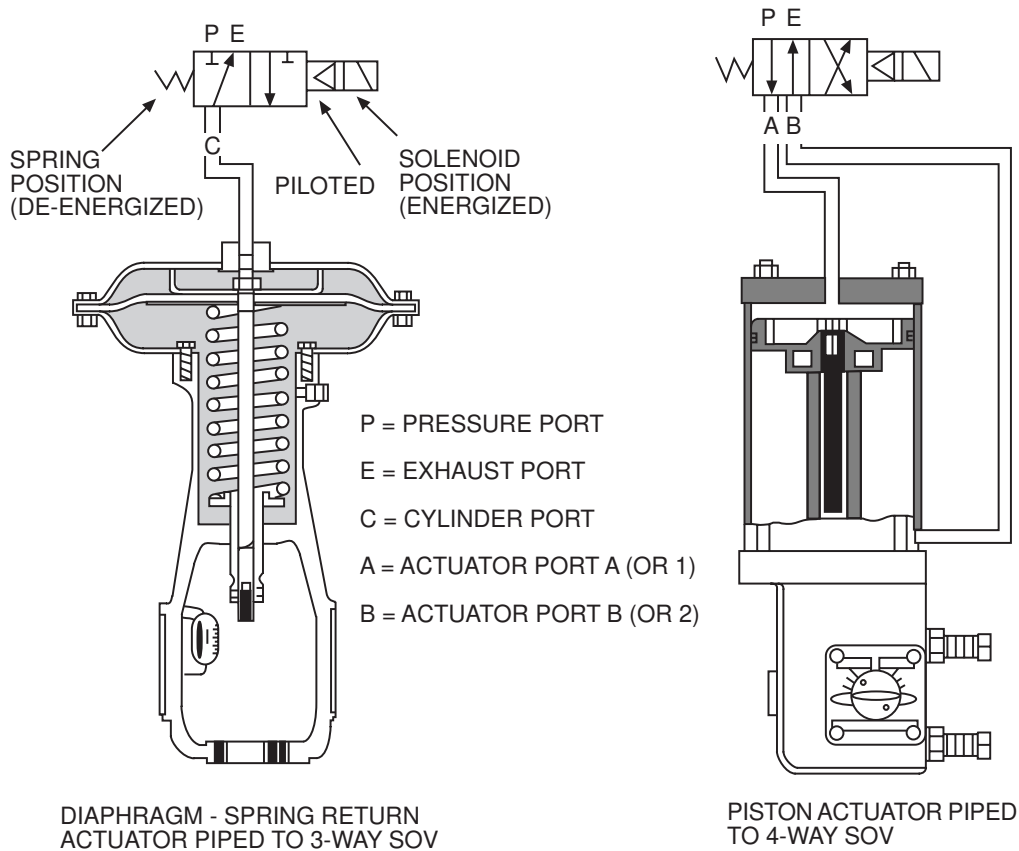

Figure 2-8
Solenoid Valve Controlling a Diaphragm and a Piston Actuator

The three-way solenoid in shown in the de-energized position, which connects the air line from the actuator to the exhaust port of the solenoid. This releases any pressure on

the diaphragm to the atmosphere and allows the actuator spring to return the actuator to the fail position.

When the solenoid is energized, it pushes against the solenoid spring and shifts to the left, applying instrument air system pressure to the top of the diaphragm, which in turn pushes the stem downward.

The four-way solenoid is also shown in the de-energized position, but the cylinder has not yet moved to its correct position. With the instrument air pressure applied to the top of the cylinder, the piston will be displaced to the bottom of the cylinder.

When the solenoid is energized, the top of the cylinder will be exhausted and the instrument air system pressure will be applied to the bottom of the cylinder. This will return the piston and stem to the top of the cylinder.

As can be seen in these two examples, solenoid control is simply on-off control, where the valve is either fully open or fully closed.

2.2.4 Rotary Shaft Piston Actuators

The difference between sliding stem and rotary shaft actuators is that rotary shaft actuators convert force (linear motion) to torque (rotary motion) in order to operate the valve.

To convert linear to rotary motion, the piston rod is attached to a lever assembly, which in turn is attached to the control valve shaft. Either the lever assembly or the valve shaft is supported by bushings or bearings in the actuator housing. This mechanism allows the conversion of linear to rotary motion and force to torque. This in turn causes the attached closure member (ball, disk, or plug) to rotate, thereby opening or closing the valve, depending on the direction of rotation. A travel indicator pointer is attached to one end of the valve shaft. This pointer indicates the degree of valve opening on a travel indicator scale, which is attached to the side cover of the actuator housing.

The actuator lever is typically secured to the valve's rotary shaft by a keyway or by splining. Splined shafts minimize deadband (lost motion). Actuator-to-valve-shaft coupling can also be accomplished with keyed shafts and connectors, or with squared ends. Index marks can be used on the shaft and lever for determining the proper mounting orientation of the control valve shaft and lever.

The piston-rod-to-lever connection moves in path that is shaped like an arc. Following this path, the piston rod moves on a plane that deviates from the vertical axis. Therefore, the simple O-ring stem seal used in sliding stem actuators to retain lower cylinder pressure will not work in rotary shaft actuators. Two different approaches to sealing lower cylinder pressure are used. The first is a dynamic or sliding seal mechanism, where the piston rod seal slides to follow the lateral motion of the piston rod. The other eliminates the need for a sliding seal by allowing lower cylinder pressure to enter the actuator housing. The necessary seal is then provided by O-rings that are installed around the actuator lever.

As the actuator is stroked, the deviation of the piston rod from a perfect vertical axis also causes the piston to cant or tip, so the piston edges do not gouge the cylinder walls. A common design approach is to tip the piston slightly at the end of stroke and to bevel or radius the edges of the piston to provide cylinder clearance.

Typical locations of travel stops are shown in Figures 2-4, 2-5, and 2-6. In the double-acting design shown, the distance traveled by the piston rod can be changed by installing a longer or shorter lower travel stop. In spring-return and spring-bias designs, cap screws limit lever rotation and can be tightened or loosened to establish travel limits.

2.3 POSITIONERS

2.3.1 Introduction

A valve positioner is a proportional controller that adjusts the output to the actuator based on control system input and feedback from the valve stem position. Pneumatic and electro-pneumatic positioners are used with pneumatic actuators to control infinite valve positioning and/or to provide greater force.

In a closed-loop control system, a measured variable (flow, level, temperature, pressure, and so on) is controlled at a desired value or setpoint. In a simple system, as shown in Figure 2-9, a transmitter senses the measured variable and sends a corresponding signal to the controller. The controller compares the incoming signal to the setpoint. If there is a deviation between the setpoint and the measured value of the variable, the controller sends a pressure signal to the actuator, thereby repositioning the valve to eliminate the deviation and achieve process control.

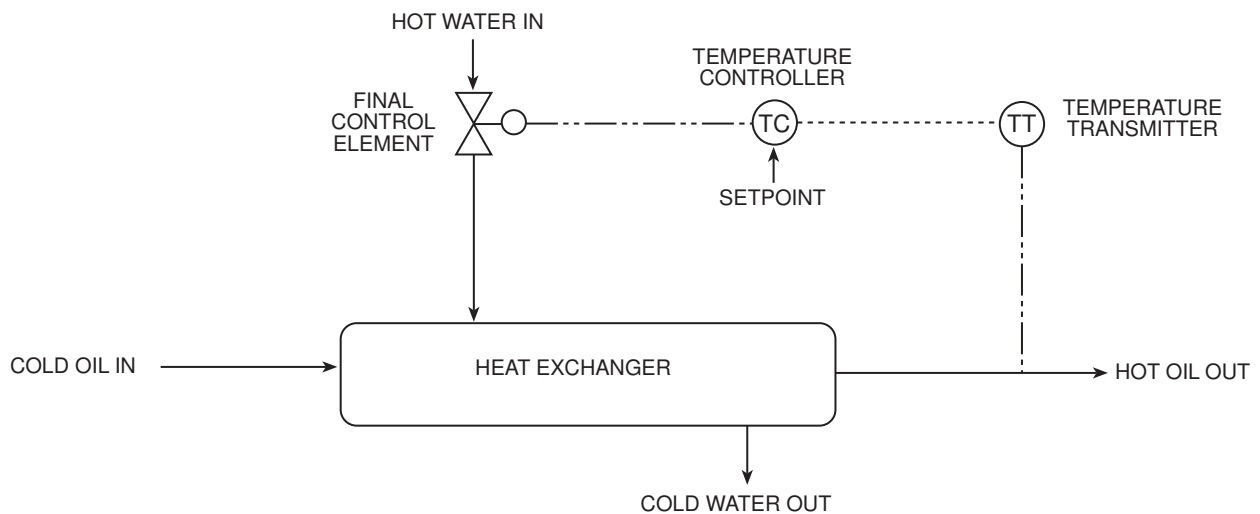

Figure 2-9
Closed Loop Elements

As the output pressure from the controller changes, the actuator is expected to produce a corrective change in valve stem position. However, there are many normal influences that can prevent this from happening. Among these are the normal effects of friction and the forces of fluid flow on the control valve closure member. When certain conditions interfere with actuator performance, a positioner can be used to improve stem positioning accuracy (Figure 2-10). The positioner receives an input signal from the controller (the controller output). This signal conveys to the positioner the desired stem position. At the same time, a feedback linkage between the valve stem and the positioner tells the positioner the actual stem position. Through mechanical means, the positioner compares the desired stem position with the actual stem position and adjusts the actuator loading pressure until the desired valve stem position is attained.

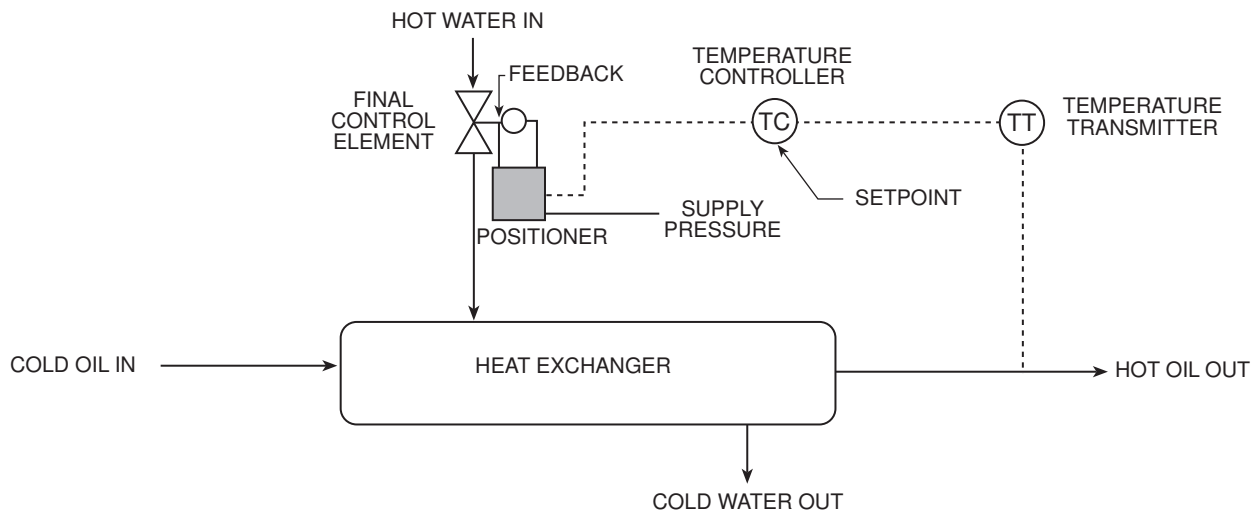

Figure 2-10
Closed Loop with Positioner

The input signal sent to the positioner is separate from the supply pressure that the positioner modulates. Therefore, an input signal of a given pressure range can be used to control the supply of a different pressure. For example, a 3 to 15 psig input signal can be used to control a higher 21 to 43 psig actuator loading pressure.

One of the key elements of positioner operation is feedback. Through the feedback mechanism, information relating the actual stem position is constantly relayed to the positioner mechanism. This feature differentiates positioners from other types of pneumatic control devices, such as relays or volume boosters.

The positioner is one of many instruments that relies on a force or motion balance for operation. The force balance is the net result of two forces determining the output of the device. In a positioner, the two forces are derived from the input signal (controller output) and the valve stem feedback linkage. The pneumatic output is determined by the balance of the two inputs.

A common misconception is that the use of a positioner always improves control. In an operating system, the dynamic characteristics of the positioner and the system process directly interface. There are some applications where the use of a positioner actually degrades system performance.

There are systems that can tolerate extra gain from the positioner, and systems in which the use of a positioner can cause instability because the total loop gain is near one at the system critical frequency. The major distinction is whether the process is fast or slow.

Fast processes are those in which a change in valve position causes a rapid change in the measured variable. For example, when the measured variable is fast flow, liquid pressure, or gas pressure in a small volume, it could reasonably be anticipated that a change in valve position will produce a rapid change in the measured variable. In these instances, the application of a positioner can actually degrade control. Fast systems using positioners can be made more stable by de-tuning the controller, but at the expense of control. Other devices, such as relays or boosters (or even no auxiliary device), can provide a better solution.

Slow processes are those in which a change in valve position results in a slow change in the process variable. For example, when the measured variable is liquid level, slow flow, temperature, or gas pressure in a large volume, the time it takes for a change in valve position to produce a change in the measured variable will take longer. In these applications, a positioner will probably satisfy the system requirements.

When the speed of the process is mid-range and difficult to classify as either fast or slow, either a booster or a positioner can be applied. Of course, there are instances when positioners must be used, such as with springless actuators.

The positioner's feedback mechanism can be altered to change the flow characteristic of a valve. Although most positioners are designed as linear devices, that is, the stem position is a linear function of positioner output, the feedback linkage or cam can be configured to produce a desired output versus input. However, it is best to characterize the valve with trim and plug changes.

Additionally, the positioner can be configured to supply extra seat load to enhance shutoff, or to provide additional capacity to decrease response time on large actuators.

2.3.2 Positioner Applications

Positioners are used to solve problems that result from the static characteristics of valves and actuators and from the dynamic considerations that are part of the operating systems.

Positioners are often used to overcome friction within the valve and actuators. Packing and seals are common sources of friction. This friction can result in the mispositioning of the valve stem or shaft. Positioners, by using feedback, sense and correct errors in valve position. Additionally, viscous fluids can gum up or solidify on internal valve parts. Positioners can be used to overcome valve seizing caused by these deposits.

2.3.3 Split-Ranging

Split-ranging (Figure 2-11) is where one control signal is used to operate two or more final control elements. An example is a process requirement with a minimum flow requirement of 5 gpm and a maximum flow requirement of 100 gpm. A valve of the preferred type that would provide control over this whole range could not be found. So two valves, one large and one small, are used in parallel. The larger valve controls the high flow rates; the smaller valve, the lower flow rates. The output is from the same control output signal.

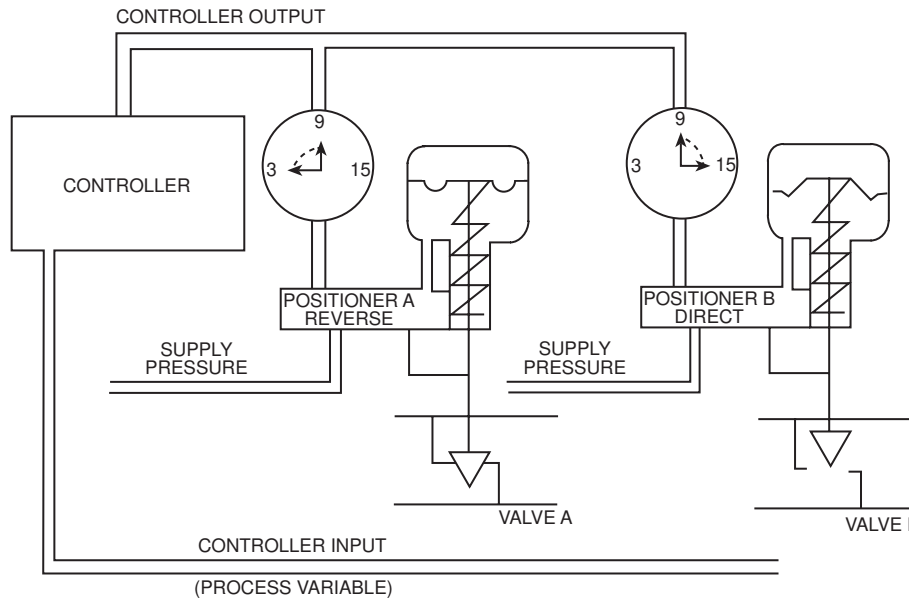

Figure 2-11
Split-Ranging

2.3.4 Positioner Operation

There is no one typical positioner in use for pneumatic control valves. This section describes the operation of three different types that cover the most commonly used positioners. Information from the manufacturer contains details of operation and calibration.

Figure 2-12 depicts a typical positioner and actuator interface for a single-acting pneumatic positioner. Supply pressure is supplied to the relay supply valve and fixed restriction. The diameter of this restriction orifice is less than the diameter of the nozzle, so that air can bleed out faster than it is being supplied when the flapper is not restricting the nozzle.

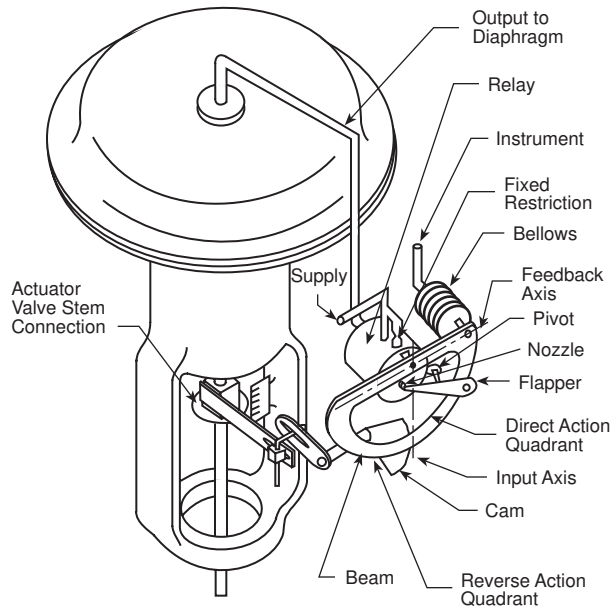

Figure 2-12
Pneumatic Positioner

When the input signal increases, the bellows expands and moves the beam. The beam pivots the flapper and restricts the nozzle. The nozzle pressure increases and moves the relay diaphragm assembly to open the supply port. Output pressure to the diaphragm actuator increases, moving the actuator stem downward. Stem movement is fed back to the beam by means of a cam that causes the flapper to pivot slightly away from the nozzle. Nozzle pressure decreases, and the relay supply valve closes to prevent any further increases in output pressure. The positioner is once again in equilibrium but at a higher input signal and a slightly different flapper position.

When the input signal decreases, the bellows contracts (aided by an internal spring) to move the beam and pivot the flapper slightly further from the nozzle. Nozzle pressure decreases, and through relay operation, the exhaust port in the relay opens to release diaphragm casing pressure to the atmosphere, permitting the actuator stem to move upward. Stem movement is fed back to the beam by the cam to reposition the beam and flapper. When equilibrium conditions are obtained, the exhaust valve closes to prevent any further decreases in diaphragm case pressure.

The principle of operation for reverse-acting units is similar, except that as the input signal increases, the diaphragm casing pressure is decreased. Conversely, a decreasing input signal causes an increase in the pressure to the diaphragm casing.

Figure 2-13 depicts an electro-pneumatic positioner, similar to the pneumatic positioner in Figure 2-12. For this electro-pneumatic positioner, the input signal is not pneumatic controller output but a current signal from the controller. This current is converted into a pneumatic pressure that is fed to the bellows. Otherwise, this type of positioner functions in the same way that a pneumatic positioner does.

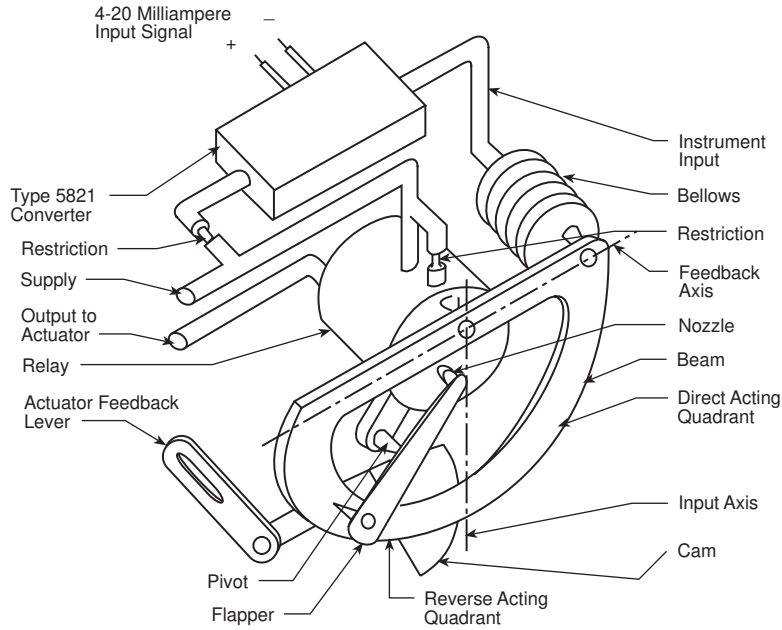

Figure 2-13
Electro-Pneumatic Positioner

Each of the positioners can be configured to be direct-acting or reverse-acting. The cam can also be changed to modify the performance of the valve from linear action to equal percentage or quick opening.

Figure 2-14 shows the schematic of a double-acting rotary valve positioner with a current-to-pressure (I/P) converter. The positioner receives an input signal from a controller that is converted into a signal pressure that is directed to cavity A in the input module. An increase in input signal pressure results in a downward force on the summing beam, pivoting the summing beam counterclockwise. This moves the flapper slightly toward the nozzle, increasing the nozzle pressure. As nozzle pressure increases, the relay beam pivots clockwise, causing relay B to increase the upper cylinder pressure and relay A to exhaust the lower cylinder pressure of the actuator.

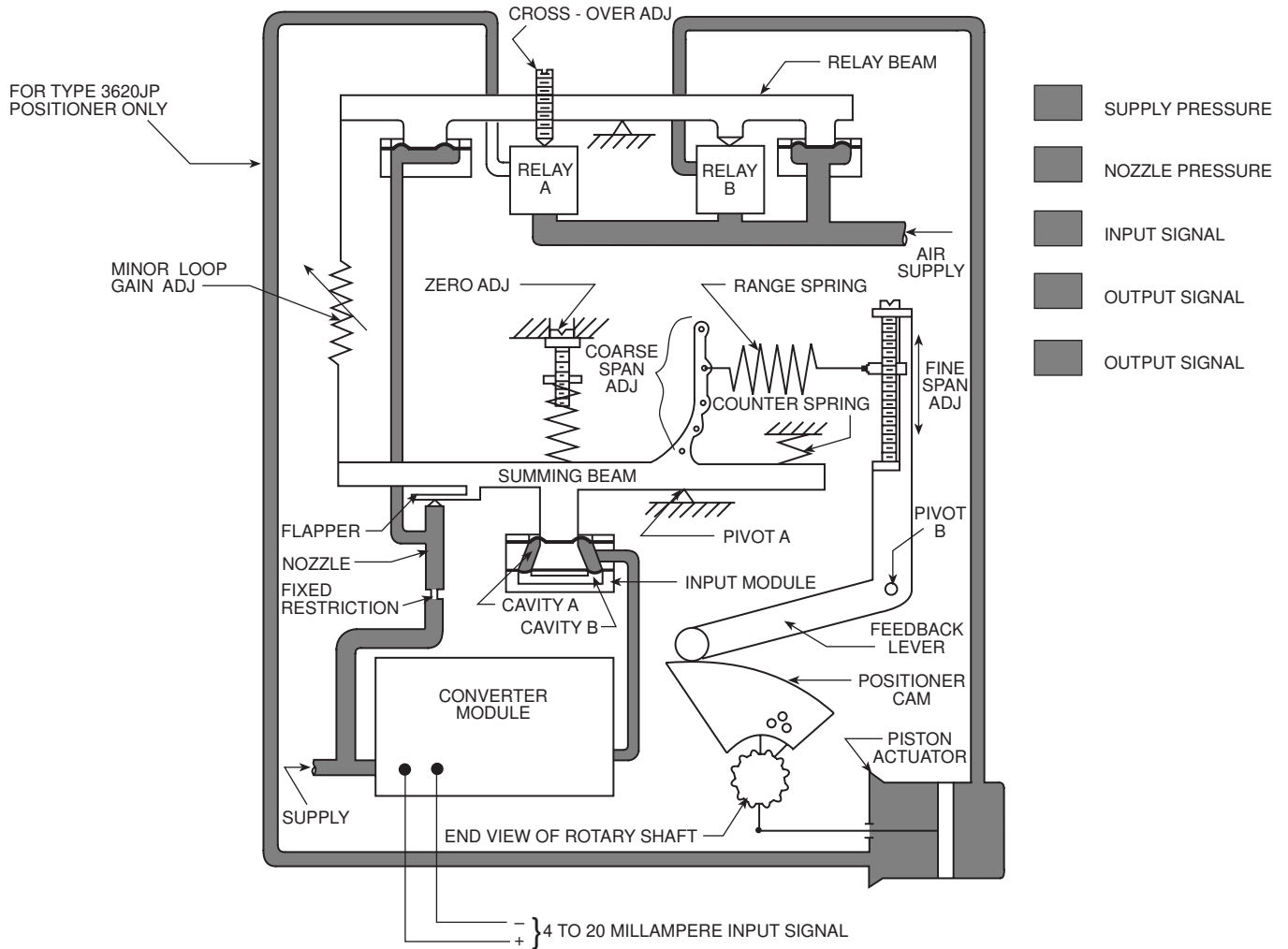

Figure 2-14
Double-Acting Rotary Valve Positioner

As a result, the actuator rod extends and the actuator rotary shaft rotates clockwise. This causes the feedback lever to pivot clockwise, and the force that is applied to the summing beam by the range spring increases. This force, which opposes the downward force on the summing beam caused by the increasing input signal pressure, continues to increase until the summing beam torques are in equilibrium. At this point, the valve shaft is in the correct position for the specific input signal applied.

For reverse action, input signal pressure is channeled to both cavities A and B. An increase in signal pressure results in an upward force on the summing beam, pivoting the summing beam clockwise and causing relay B to exhaust the upper actuator cylinder pressure to the atmosphere and relay A to increase the lower actuator cylinder pressure. As a result, the actuator rod retracts, and the actuator rotary shaft rotates counterclockwise. This causes the feedback arm to pivot counterclockwise, reducing the force applied to the summing beam by the range spring.

As the valve shaft rotates counterclockwise, the range spring force to the summing beam continues to reduce the force applied to the summing beam until the torques are in equilibrium.

Figure 2-15 depicts another pneumatic side-mounted positioner. In this positioner, the pilot valve can be either a bellows or diaphragm design with similar operation.

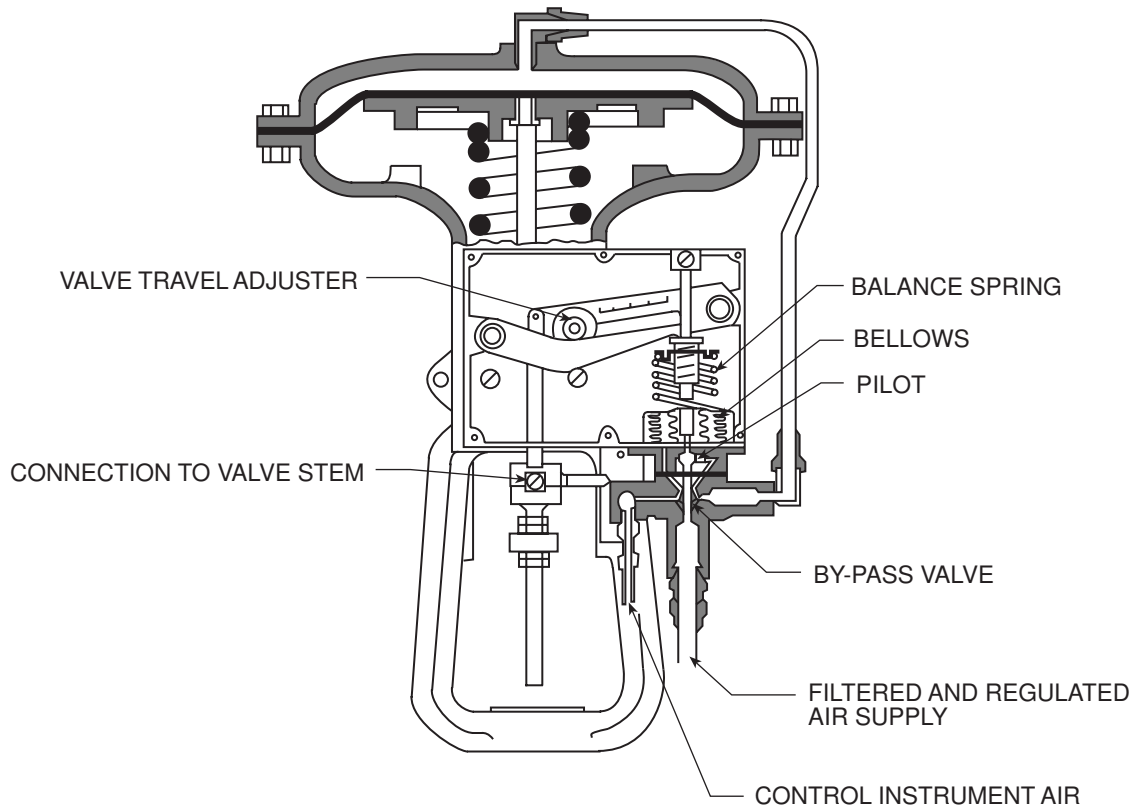

Figure 2-15
Pneumatic Positioner

Figure 2-16 shows a schematic of this positioner. As the input pressure increases, the input bellows places increasing force to the thrust assembly. This moves the thrust assembly up and restricts the exhaust port, thereby increasing the supply pressure to the actuator and causing the stem to move down. This movement is fed back to the positioner by a parallel-lever gain mechanism. The output of the gain mechanism is applied to the top of the range spring and to the thrust assembly. At this point, the two forces once again equal each other and the thrust assembly comes to equilibrium.

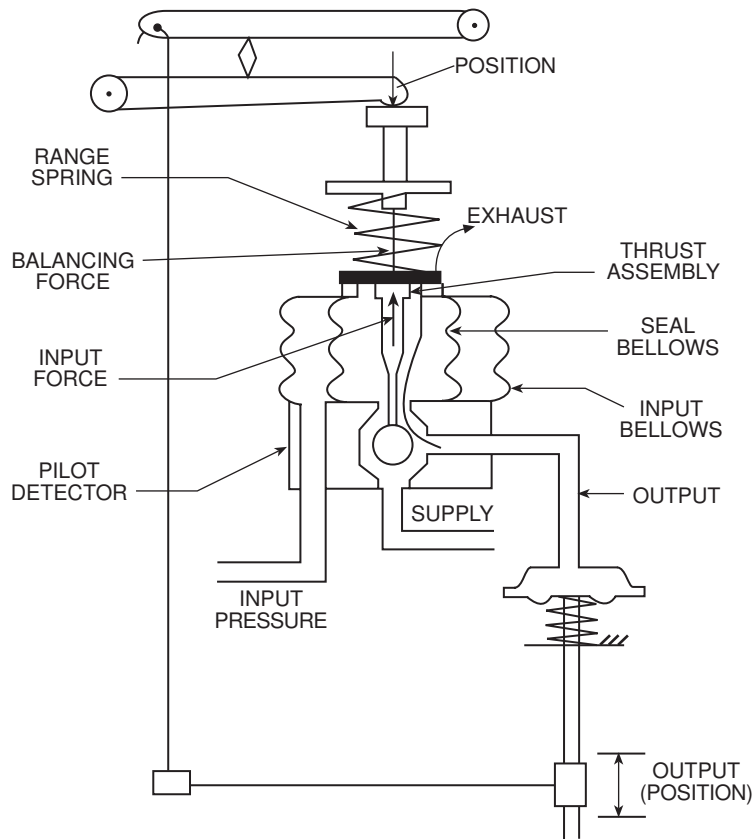

Figure 2-16
Pneumatic Positioner Operation

2.4 TRANSDUCERS

A transducer is a device that converts a signal from one form to another. In pneumatic valves, a transducer typically converts the current or voltage from the control system into pressure.

When the signal is current (I), the standard input is 4 to 20 mA and the output is either 3 to 15 psi or 6 to 30 psi. These types of transducers are referred to as I/P transducers. Figure 2-17 shows a typical I/P transducer. The input signal provides the power to the coil, which positions the armature and controls flow through the nozzle. The nozzle pressure controls the associated relay, which controls the output pressure.

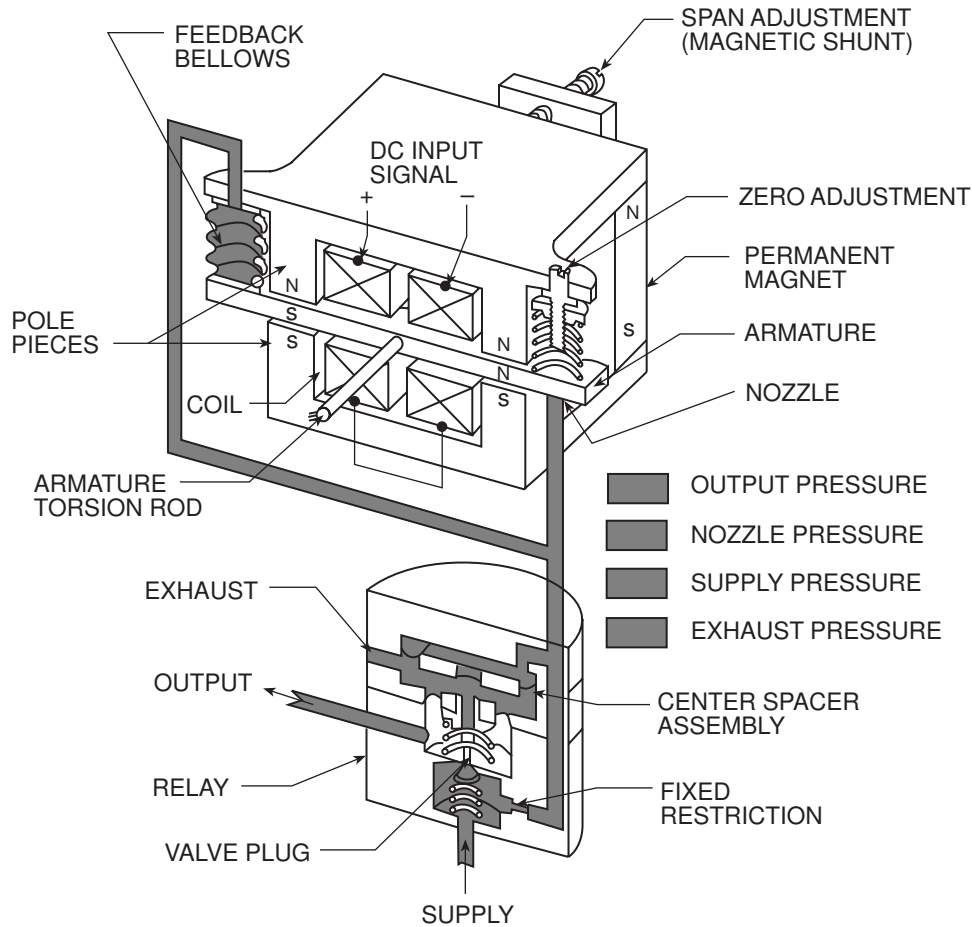

Figure 2-17
Typical I/P Transducer

When the input signal is voltage (E), the standard input is 0 to 10 V. These transducers are referred to as voltage-to-pressure (E/P) transducers and have the same output ranges as the I/P transducers.

2.5 PRESSURE BOOSTER

A pressure booster is used to increase the supply pressure from a controller. Figure 2-18 shows a single-seated, air-to-open valve with a 6 to 30 psi spring. The heavy spring can be used to close the valve against a high upstream pressure; however, the normal controller output of 20 psi cannot open the valve fully. A 2:1 pressure booster makes the system operational.

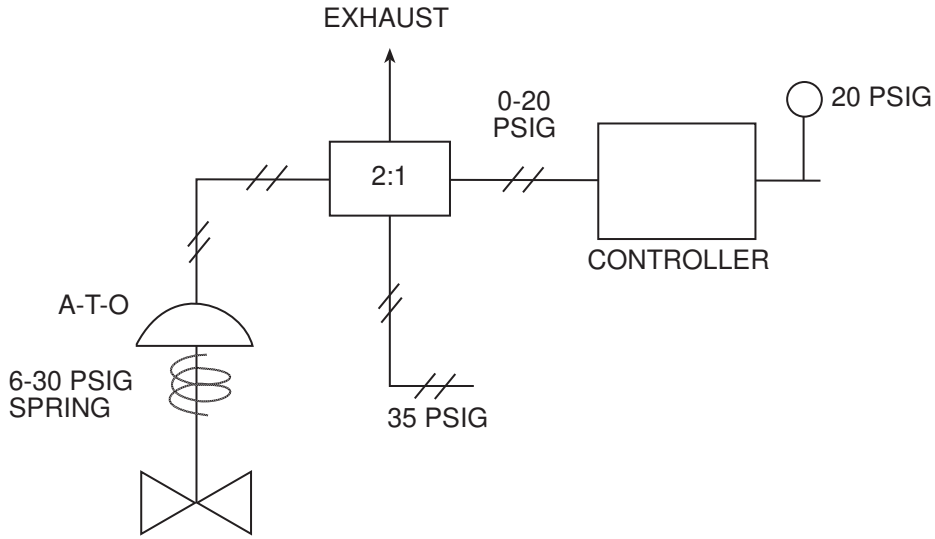

Figure 2-18
Typical Pressure Booster

2.6 VOLUME BOOSTER

A volume booster is typically used to increase the response of a pneumatic controller to the control valve. This is done by increasing the air flow rate to the actuator. Figure 2-19 shows a typical arrangement. The controller applies its output signal to the booster instead of to the control valve. The pilot valve in the booster requires about 1 cubic inch of air to reposition. The air to operate the valve passes through the booster at 35 standard cubic feet per minute, increasing the stroking time of the control valve.

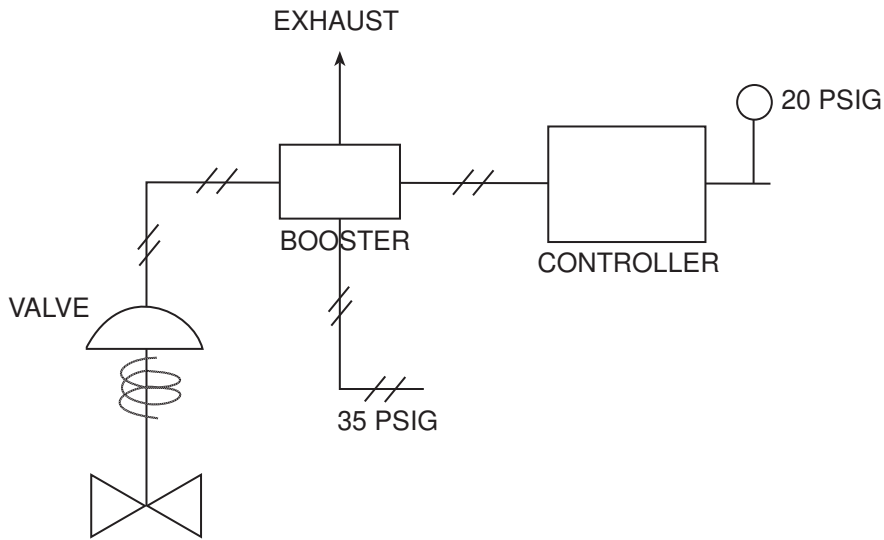

Figure 2-19
Typical Volume Booster

3

FAILURE MODE ANALYSIS

3.1 INTRODUCTION

The evaluation of air-operated valve (AOV) failure modes through statistical analysis on current industry data proves to be difficult due to the diversity of the valve types, sizes, manufacturers, and so on. It is made even more difficult due to the reporting methods employed by the individual power plants.

The purpose of this section is not to develop a statistical failure rate for air-operated valves, but to present reliability and failure information that can provide a basis for a maintenance program that will reduce observed failures.

The primary source for the investigation leading to the development of this guide was the Institute of Nuclear Plant Operation's (INPO) Nuclear Plant Reliability Data System (NPRDS) information on pneumatic-operated valves. Because NPRDS data does not record component failures from balance-of-plant (BOP) systems, there are many AOV failures that go unreported.

Revision 0 of this report conducted an NPRDS analysis by reading the narratives associated with each AOV failure from 01/01/87 to 12/31/91. This analysis was conducted to determine which *systems* had the highest number of AOV failures and then which components in the valves contained in those systems had the highest percentage of failures. For these key components, an evaluation was made of which specific problems were plaguing each specific component. Each plant can look at past failure rates for these components to determine approximate periodicities for future maintenance activities.

The current revision looked at current AOV failures from 6/1/94 to 6/1/95 to determine what particular subcomponents or accessories have the highest failure rates.

From this information, a fully tailored preventive maintenance program can be established that is cost-effective and should produce increased reliability of components with high failure rates.

3.2 NPRDS DATA

3.2.1 Failures by System

When establishing a preventive maintenance program for AOVs, it would be useful to first order the systems by the percentage of AOV failures. To accomplish this review by system, NPRDS failures for five past years (1/1/87 - 12/31/91) for pressurized water reactor (PWR) and boiling water reactor (BWR) plants can be examined. Table 3-1 shows AOV failures by system for PWRs, and Table 3-2 shows AOV failures by system for BWRs.

**Table 3-1
PWR AOV Failures by System**

System	Percent of Total Failures
Main Steam	24%
Main Feedwater	16%
Chemical Volume and Control	13%
Containment Isolation	11%
Condensate	7%

**Table 3-2
BWR AOV Failures by System**

System	Percent of Total Failures
Condensate	24%
Main Steam	22%
Main Feedwater	12%
Nuclear Steam Supply	7%
Suppression Pool Support	7%

Fortunately, this review does not show failures evenly distributed over all systems, but it indicates three or four systems that are responsible for a high percentage of AOV failures. This one piece of information can help maintenance personnel focus their efforts on these particular systems as a start to a more cost-effective maintenance program.

The data can be further refined to the application level (for example, the main feedwater regulating valve operator). Some limitations, however, occur at this level of detail. NPRDS has identified major applications within each system that is reported. For BWR condensate systems, however, there are no applications identified; hence, the major failure components have to be identified by the next level of detail, which is the component identification number which tends to be plant-specific. This makes an overall failure evaluation very difficult for this type of system. This does not, however, limit the ability of a utility maintenance group from doing this evaluation for their own plant data. For the general audience of this guide, no additional information can be obtained.

Table 3-3 gives the breakdown of AOV failures for a PWR main steam system by application. An interesting fact was the high level of failures for the turbine dump valves. In fact, this valve represents almost 8% of the total AOV failures reported for PWRs. Table 3-4 shows the breakdown for PWR main feedwater systems. It is not surprising that the main feedwater regulating valve operator is the main failure application. Once again, the unknown applications need to be investigated for each specific plant.

Table 3-3
PWR Main Steam System Failures by Application

Application	Percent of Main Steam System Failures
Turbine Dump Valve	43%
Power Operated Relief Valve	23%
Main Steam Isolation Valve	11%
Atmospheric Discharge Valve	6%

Table 3-4
PWR Main Feedwater System Failures by Application

Application	Percent of Main Feedwater System Failures
Main Feed Regulating Valve	36%
Main Feed Regulating Bypass Valve	24%
Main Feed Containment Isolation Valve	8%
No Application Identified	32%

The next step is to go back over the same data to determine the specific problems that are occurring on each application that is identified. This process helps to further refine the maintenance program to allow focused preventive activities.

Table 3-5 shows the failure causes for main steam turbine dump valve operators. Because of the severe environment for these valves, wearing out and failing of gaskets and positioners is not surprising and helps to give a direction to a maintenance program for these valves. Elastomer problems for these valves is 18% of the total. An increased elastomer inspection frequency could help to reduce these failures.

**Table 3-5
PWR Main Steam Turbine Dump Valve Failure Causes**

Failure Cause	Percent of Main Steam Turbine Dump Valve Operator Failures
Positioner Adjustment	16%
Air Leaks	11%
Pilot Valve Wearout	11%
Positioner Wearout/Damage	9%
Gaskets and Piston Ring Wearout	7%
Broken Feedback Arm	6%
Diaphragm Wearout	5%
Total Elastomer Related Failures	18%

Table 3-6 displays the failure causes for PWR power-operated relief valves. The positioner again is a major source of problems for this valve group, and overall elastomer problems equal 28% of all failures.

**Table 3-6
PWR Power-Operated Relief Valve Failure Causes**

Failure Cause	Percent of Power Operator Relief Valve Operator Failures
Positioner Adjustment/Failure	25%
Gasket Failure	12%
Air Leak	10%
Diaphragm Failure	9%
Vibration Problems	6%
Total Elastomer Related Failures	28%

Also notable for the last two valves is the high percentage of air leaks that are reported as the failure cause. Air leaks are most likely caused by vibration and are many times reported as vibration-related. An increased inspection frequency for connector tightness could help to reduce these reported failures.

Table 3-7 shows the failures for the PWR main feedwater regulating valve operators. In this case, the high usage of this valve as a flow control valve in a slightly less severe environment than the previous valves makes the increased positioner problems and the decreased elastomer problems expected. Air leaks, however, continue to provide close to 10% of the problem.

Table 3-7
PWR Main Feedwater Regulating Valve Failure Causes

Failure Cause	Percent of Main Feedwater Regulating Valve Operator Failures
Positioner Adjustment/Failures	31%
Solenoid Failures	21%
Pilot Relay Failures	9%
Air Leaks	9%
Gasket/O-Ring Failures	8%

For BWR systems, the data provides no additional surprises but helps to reinforce the evaluation process that was started with the PWRs. Table 3-8 shows application failures for BWR main steam systems, and Table 3-9 shows application failures for BWR main feedwater systems.

Table 3-8
BWR Main Steam System Failures by Application

Application	Percent of Main Steam System Failures
Containment Isolation Valve	52%
Automatic Depressurization Safety Valve	24%
Turbine Bypass Valve	2%
No Application Identified	21%

Table 3-9
BWR Main Feedwater System Failures by Application

Application	Percent of Main Feedwater System Failures
Main Feedwater Regulating Valve	27%
Regulating Valve Bypass Valve	10%
No Application Identified	63%

Table 3-10 gives additional information on BWR main steam isolation valves with elastomers and pilot-regulating valves showing the highest number of problems and the speed control valve having enough failures to warrant additional attention also. Table 3-11 shows BWR main feedwater regulating valve failures with the attention shifted to air leaks and vibration-related failures and less need for positioner attention.

Table 3-10
BWR Main Steam Isolation Valve Failure Causes

Failure Cause	Percent of Main Steam Isolation Valve Operator Failures
O-Ring and Seal Failures	19%
Speed Control Valve Adjustment/Failure	13%
Solenoid Failure	13%
Operator Related Wearout	6%
Total Elastomer Related Failures	28%

Table 3-11
BWR Main Feedwater Regulating Valve Failure Causes

Failure Cause	Percent of Main Feedwater Regulating Valve Operator Failures
Air Leaks	21%
Debris Related Failures	17%
Vibration Related Failures	8%
Positioner Adjustment/Failure	8%
O-Ring Failure	8%

3.2.2 Detailed Sub-component Failure Analysis

The next analysis takes a look at all AOV failures for a single year and categorizes each failure by subcomponent. This approach allows component engineers to get an overall view of the failure causes by subcomponent and to evaluate the correctness of their established replacement frequencies for these subcomponents.

The initial cut of the AOV failures for the time period 6/1/94 to 6/1/95 is shown in Table 3-12.

Table 3-12
Subcomponent Failure from 6/1/94 to 6/1/95

Rank	Sub-Component	% of Failures
1.	Actuators	30.0
2.	Solenoid Valve	22.0
3.	Limit Switch	7.5
4.	Positioner	3.2
5.	Spring	3.2
6.	Air Line	3.0
7.	Maintenance Error	2.4
8.	Design	2.0
9.	Stem	2.0
10.	Bolting	1.5
11.	Coupling	1.5
	Others	21.7

As expected, the highest failures are within the actuator. For those failures, 35% was attributable to diaphragm failures, 29% to seal and O-ring failures, 13% to bolting related failures, and 4% to piston binding.

The next highest failure was on accessory solenoid valves at 22%. For these failures, 56% were due to failure of the solenoid-operated valve (SOV) diaphragm, 16% due to coil failure, 12% due to sticking problems, and 7% due to dirt or clogging.

Limit switches accounted for 7.5% of the total failures with 63% of these failures due to vibration-related problems.

The remainder of the failures are individually small contributors to the overall failures, but they account for 40.5% of AOV failures and should be considered when evaluating your current maintenance programs.

3.3 CAUTIONS AND CONCERNS

The following covers some points that should be considered when performing this type of data analysis:

1. NPRDS reporting is required only for safety-related systems and, in many cases, does not include balance-of-plant systems. Each maintenance department should use plant-specific information to evaluate these systems.

2. The above analysis was done for all plants that report to NPRDS and can be considered to represent the average of expected failure causes. Each individual plant might see different distributions of failures and failure causes. This should be evaluated by each plant.

3.4 SUMMARY

While this type of analysis might seem to be very labor intensive, the actual time spent for the final overall benefit is small. When the problems can be defined, the application of the information into a preventive maintenance program can provide quick rewards to a maintenance group through improved reliability of high failure valves and less time spent on parts replacement or refurbishment of low failure valves.

While most in-service inspection (ISI) programs will also help to identify these problem areas, the use of NPRDS data for each plant provides a quick method of incorporating many years of historical failure data into a preventive maintenance program today. These lists of failure-prone valves can be refined as additional data is collected on the high failure components.

For diaphragm failures, Section 7 of this manual provides a complete discussion of diaphragm manufacturing, shipping, handling, installation, and failure analysis to help understand the primary mechanism for spring and diaphragm actuators.

Solenoid valve failures are covered in detail in the *NMAC Solenoid Valve Maintenance Guide* (NP-7414).

The rest of the subcomponents are covered generally in Section 4 on troubleshooting and maintenance.

4

TROUBLESHOOTING AND RECOMMENDED CORRECTIVE MAINTENANCE PRACTICES

This section reviews the troubleshooting and recommended corrective maintenance practices on the accessories of air-operated valves (AOVs).

The accessories covered by this section are those that are most common on control and isolation (on-off) valves, including positioners, transducers, and volume boosters. In most cases, as appropriate, the air tubing associated with the component should be considered part of the component.

4.1 TROUBLESHOOTING GUIDELINES

The following subsections provide general symptoms associated with valve operation and provide information about what to check on an actuator or accessory.

4.1.1 Control Valve Problems

4.1.1.1 Valve will not respond to signal

The first actions should be to determine if the problem is electrical or pneumatic, or even if a physical constraint might be keeping the valve from operating.

A few checks can be conducted from the control room, such as verifying adequate instrument air pressure and control power availability.

The next check includes local investigation by an operator, a maintenance mechanic, or an instrument and control specialist. They can determine quite a bit from just looking over the valve.

Check the simple things first. It can be extremely embarrassing and wasteful to tear down a valve searching for a problem when the real culprit is a hidden isolation valve or a cocked packing gland.

Be sure to check the following:

- Check the system in accordance with the piping and instrumentation drawings (P&IDs). Verify that all air supply valves are open.
- Open the petcock on the filter regulator to verify the air pressure. Instrument gauges are often not functional or accurate.
- Verify the air supply to the valve.
- Listen for blowby at the seals or diaphragm. A ruptured diaphragm is a common problem. Use a leak detection liquid to search for external leaks.
- Feel the actuating solenoid, if appropriate. If it is warm, it is energized.
- Feel the venting solenoid on piston-operated valves.
- A loss of control power might indicate that a fuse has blown.
- Check all air lines to see that they are not crimped or broken.
- Check the valve for adequate operating clearances. (Direct interference from scaffolding built too close to a valve has prevented more than one valve from functioning.)
- If the valve was just installed, check the flow arrow to ensure that the process flows in the proper direction. Flow above the seat can add pressures that the actuator might not be able to overcome.
- Check the air to and from a piston actuator to ensure that the supply is not connected to the exhaust and vice versa. A pneumatic lock can be caused by the switching of air lines.
- Check the packing gland. Improper gland configuration is a leading cause of stem binding.
- Check the coupling to ensure that it is tight and still connected.

Further investigation requires component disassembly.

4.1.1.2 Valve will not fully open

Investigation into this problem requires access to the valve and might require disassembly. Some of the possible causes that can be checked locally are:

- Inadequate air pressure. Even if the pressure at the line header is sufficient, modifications that add additional users can cause such a drop in pressure that the valve will not fully stroke. Diaphragm failures and any component (air lines, internal or external positioner leaks) between the header and actuator might cause distribution leaks.
- Incorrect positioner calibration is another common problem.
- Loose or damaged limit switches can also stop a valve from going full cycle. If the limit switch is reached before the desired end travel is attained, the valve can stop short.
- Improper setting of travel limiter (if this is an installed option).

Other problems that require disassembly include:

- Bent stem on actuator.
- Damaged valve trim.
- Weak or improper actuator spring.
- Incorrect spring preload.
- The valve might not be able to overcome process pressure due to a change in process conditions. A new control valve might be required.

4.1.1.3 Excessive packing leaks

Packing presents one of the major problems affecting AOVs. Some of the more common problems are:

- Insufficient packing compression.
- Insufficient packing compression from a loose or cocked gland.
- A scored or heavily pitted valve stem or stuffing box.
- Corrosion on the valve stem.
- Improper size or type of packing.
- Split ring packing improperly aligned. (Split-ring packing rings should be lined up with their cuts or separations staggered.)
- Improper stem alignment.

4.1.1.4 Valve travel sluggish or slow

Few things cause this symptom and they are normally easy to ascertain:

- Packing gland too tight.
- Bent valve stem.
- Insufficient instrument air pressure.
- Process pressure increase (backpressure)
- Excessive lubrication in the piston actuator.
- Restricted flow to the exhaust solenoid or piping. (This can be caused by various solenoid problems, see EPRI NP-7414, *Solenoid Valve Maintenance Guide*.)
- Crimped or too small air tubing.

4.1.1.5 Valve travel jumps

This is typically a packing and stem interface problem. Possible causes are a bent actuator stem or a packing gland that is too tight. Other less likely causes are corrosion of valve internals, stem or valve misalignments, and some controller problems.

4.1.1.6 Flange leakage

Flange leakage covers the mating flanges on the piping to the valve and also the bonnet or bottom cap to the valve. These leaks can be caused by a multitude of problems but a typical cause is one of the following:

- Gasket problems. Including reuse of the old gasket, no gasket, gaskets of the wrong material or size, or improper gasket crush. (See EPRI/NMAC TR-104749, *Static Seals Maintenance Guide*.)
- Bolting problems. Using old bolts that do not torque properly, insufficient torque applied for the service, or an incorrect torque pattern. (See EPRI/NMAC TR-104213, *Bolted Joint Maintenance and Applications Guide*.)
- Surfacing problems. The valve flanges are pitted, eroded, corroded, or uneven. Mating polished flanges that are even 0.001 of an inch off of 90 degrees will leak in service. Check the installation of new parts.
- The flange is not designed properly for internal and external (actuator) forces.

4.1.1.7 Valve will not rotate

Rotary valve problem. Some of the more common causes are listed here:

- Valve stops set wrong, stopping the valve mechanically before it rotates.
- Broken stem or yoke.
- Overtravel can cause severe damage to eccentric valves.
- Dirt or corroded valve seats can cause broken stems.
- Insufficient actuator torque due to diaphragm or piston seal leakage.
- Changing service conditions, higher pressures, and greater pressure drops can stop the valve from rotating due to insufficient torque.
- Valve packing too tight.
- Galled or damaged bushings.
- Broken seal, swelled seal, or a seal that came out of its retainer.

4.1.1.8 Poor flow control

Poor flow control can be attributed to many factors depending on the type of valve and actuator.

Poor flow control in globe valves can be caused by:

- Packing too tight.
- Deformed cage.
- Debris in the valve.
- Damaged piston rings.
- Bent stem.
- Faulty positioner.
- Valve not right for the process conditions.
- Plug damage from foreign objects. Erosion, corrosion, and cavitation are other causes of damage.

Poor flow control in rotary plug valves can be caused by:

- Broken shaft. The actuator strokes, but the valve plug does not move.
- Improper actuator adjustment. The ball or plug might not be reaching either the fully open or the fully closed position.
- Plug damage from foreign objects. Erosion, corrosion, and cavitation are other causes of damage.
- Damaged bushings can cause the drive shaft to stick. It then jumps from one position to another.
- A bent shaft can cause the shaft to bind during each stroke.
- A twisted shaft indicates a position that is untrue in regard to disk and seat. The valve can indicate full open or full closed and really be mid-range.
- System line bolting has been unevenly torqued or over-torqued. It can cause excessive friction between the seal and the ball.

Poor flow in butterfly valves can be caused by:

- Improper disk orientation. Fishtail disks perform satisfactorily when the tail opens toward the downstream side of the valve. If the valve has been installed backwards or if the disk was improperly installed, the valve will not provide adequate flow control.
- A damaged disk.
- Foreign objects that restrict the disk from achieving flow control position.

4.1.1.9 Cycling

Cycling can be caused by the following:

- An erratic actuator supply pressure.
- A defective or improperly calibrated positioner.
- Incorrect actuator size. (Cycling caused by this situation can cause early packing failure, diaphragm failure, and damage to the seats and disks from the pounding.)
- Inadequate spring preload.
- Improperly sized solenoid valves.
- Incorrect packing installation.

Table 4-1 summarizes the control valve problems and their causes.

**Table 4-1
Control Valve Problems**

PROBLEM	Valve will not respond to signal	Valve will not fully open	Excessive packing leaks	Valve travel slow	Valve travel jumps	Flange leakage	Valve will not rotate	Poor flow control	Cycling
CAUSE									
Improper valve assembly	X	X	X			X	X	X	
Damaged parts ¹	X	X	X	X	X	X	X	X	X
Design problems	X		X						
Improper travel adjust/calib.		X							X ²
Change in characteristics				X			X		
Solenoid failure	X						X		X
Instrument air out of specs.				X				X	
Wrong parts		X	X			X			
Improper installation ³	X	X	X		X	X		X	

¹ Includes reuse of old gaskets and elastomers.

² Problem associated primarily with piston actuators.

³ Includes problems with over torque and reverse installation.

4.1.2 Actuator Problems

The problems associated with actuators are normally easy to repair because the actuators do not have to be removed from the fluid system. Many times a visual inspection of the actuator in the field gives an immediate indication of poor performance. An ultrasonic sensing device to locate small leaks is a good tool for the technician to utilize during this inspection.

4.1.2.1 Erratic or jerky throttling

Erratic or jerky throttling can be caused by a fluctuating air supply, an unsteady electronic/pneumatic signal, or a binding packing problem. A few minutes of watching the valve cycle can indicate which of these problems is the cause. Adjustment of the positioner or other control device can produce the desired result.

4.1.2.2 Failure to fully retract or fully extend

Failure to fully retract or fully extend is treated as the same problem for linear actuators. The usual causes are:

- Low supply air pressure. This could also include air systems on infrequently used valves. Also, the number of instruments being supplied by an air line might have a greater volume than can be made up through the air line. In this case the valve might not close or open, or might perform these actions extremely slowly.
- Air leaks. This can cause insufficient air pressure to the actuator.
- Improper bench set.
- Travel stops not properly set. On rotary actuators, the mechanical stops can be set so that the actuator travel stops prior to the valve closure.
- Incorrect coupling between the actuator and the valve stem. This and wrong travel stops have similar symptoms.
- Limit switches out of proper adjustment. This can cause the actuator to cease movement prior to opening or closing.
- “Gummed-up” solenoid valves. Lubrication of piston actuators can gum up solenoid valves. This can keep the vent valve open and cause the piston to stay in the mid position or spring detent.
- Higher actual process pressure than used for actuator selection.
- Improper stem alignment, cage-to-plug alignment, or bonnet-to-body alignment.
- Damaged cylinder or piston rings are problems peculiar to piston actuators. Any damage that permits air flow from the high- to the low-pressure side of the piston can end up causing a pneumatic lock or insufficient force to move the actuator. A

temporary fix might be to add an O-ring to the piston exterior and add a lubricator. If the air leaks are small and the pressure is low, this repair can hold up for an extended time, possibly until the next outage.

- Elastomers in either diaphragms or seals that start to crack or break are a major cause of actuator failure and degradation.

Problems with failing elastomers should be investigated by determining the exact environmental parameters the elastomers are subjected to and replacing them accordingly. See EPRI NP-6731, *Guide to Optimized Replacement of Equipment Seals*.

Tables 4-2 and 4-3 summarize problems and causes for diaphragm and piston actuators, respectively.

**Table 4-2
Diaphragm Actuator Problems**

PROBLEM	Erratic or jerky throttling	Failure to fully retract	Failure to fully extend	Cycling	Failure to stroke	Sluggish/slow	Slow in increasing air pressure direction	Slow in decreasing air pressure direction
CAUSE								
Actuator supply pressure low		X	X		X	X		
Actuator supply pressure high	X				X ¹			
Actuator supply erratic	X			X				
Unsteady signal	X			X				
Improper bench set		X	X					
Positioner	X				X	X	X	X
Wrong travel stops/calibration		X	X					
Increased packing friction						X		
Actuator spring too large							X	
Actuator spring too small								X
Air leak (diaphragm, stem seal, or case joint)							X	
Leaks		X	X		X	X		
Solenoid valve failure				X	X	X		
Air supply tubing too small or crimped						X		
Actuator too large						X		

¹ Can cause the positioner to fail.

**Table 4-3
Piston Actuator Problems**

PROBLEM CAUSE	Erratic or jerky throttling	Failure to fully retract	Failure to fully extend	Cycling	Failure to stroke	Sluggish/slow	Slow in increasing air pressure direction	Slow in decreasing air pressure direction
Actuator supply pressure low		X	X		X	X		
Actuator supply pressure high	X				X ¹			
Actuator supply erratic	X			X				
Unsteady signal	X			X				
Improper bench set		X	X					
Positioner	X				X	X	X	X
Wrong travel stops/calibration		X	X					
Lubrication ²		X	X		X	X		
Increased packing friction						X		
Actuator spring too large							X	
Actuator spring too small								X
Leaks		X	X		X	X		
Damaged cylinder or piston rings/seals		X	X	X	X	X		
Solenoid valve failure				X	X	X		
Air supply tubing too small or crimped						X		
Actuator too large						X		

¹ Can cause the positioner to fail.

² Lack of lubrication permits the actuator supply air to migrate to the opposite side of the piston.

4.1.3 E/P OR I/P Transducer Problems

Table 4-4 summarizes the E/P or I/P transducer problems, causes, and resolutions.

Table 4-4
E/P or I/P Transducer Problems

Problem	Possible source	Resolution
With a known input, transducer signal will not provide the correct output pressure.	Zero and span not correct.	Calibrate the transducer, using the manufacturer's procedures.
	At the top end output, there is an internal or external air leak.	Check the external air lines with a soap-type solution and correct the leak if one is found. Internal leakage. Replace the relay or unit as applicable.
With a constant input signal, the valve is cycling.	Internal or external air leak.	Check the external air lines with a soap-type solution and correct the leak if one is found.
		Internal leakage. Replace the relay or unit as applicable.
	Failure of compensating bellows.	Replace the bellows or unit as applicable.
	External vibration.	Mount the transducer on a stable surface.
	Miscellaneous internal failure.	Replace the transducer.

4.1.4 Positioner Problems

Table 4-5 summarizes the positioner problems, causes, and resolutions.

**Table 4-5
Positioner Problems**

Problem	Possible source	Resolution
With a known input, the positioner signal will not provide the correct output (valve position).	Zero and span not correct.	Calibrate the positioner using the manufacturer's procedures.
	At the top end output, there is an internal or external air leak.	Check the external air lines with a soap-type solution and correct the leak if one is found. Internal leakage. Replace the relay or unit as applicable.
	At top end output.	The spring is too large or starting to block.
Sluggish or erratic operation.	Internal or external air leak.	Check the external air lines with a soap-type solution and correct the leak if one is found. Internal leakage. Replace the relay or unit as applicable.
	Positioner to stem linkage is binding.	Eliminate the binding linkage.
	Worn linkage.	Replace the linkage.
	In a double acting piston actuator, the steady-state positioner output pressure might be low (It should be between 60 and 75% of the supply pressure, depending on the manufacturer).	Adjust the relay nozzle to obtain the proper pressure level.
	Dirty orifices or filters.	Clean the orifices or filters.

4.1.5 Volume Booster Problems

Table 4-6 summarizes the volume booster problems, causes, and resolutions.

Table 4-6
Volume Booster Problems

Problem	Possible source	Resolution
Sluggish operation.	The internal or external bypass is not closed enough to get quicker response.	Close the bypass until proper operation is obtained.
	The sensing diaphragm or upstream piping is leaking.	Check for leaks and correct.
Erratic operation.	The internal or external bypass is closed too much for proper operation.	Open the bypass until proper operation is obtained.
Continual leakage through exhausts with no change in signal.	Internal or external bypass is closed too much for proper operation.	Open the bypass a little.
	Leaking diaphragms.	Inspect and replace the diaphragms as required.
	Internal valves leaking by.	Inspect and replace the valves as required.

4.2 MAINTENANCE PHILOSOPHY

The proper operation of all air-operated valves is of the utmost importance for the continued reliability and operation of power generation facilities. Air-operated valves impact virtually every piping system within the plant. Degradation or failure of any of these valves can cause transients that further affect the operation of many other plant systems. They might, in some cases, affect the plant’s availability factor.

To improve air-operated valve availability and, consequently, the overall plant reliability, the valves must be periodically and professionally maintained to reduce the failure rate now being experienced in the power industry. Air-operated valves should be maintained to operate at optimum efficiency. To accomplish this, most plants will need to change from a “reactive” or “corrective” maintenance mode to a “pro-active” or “preventive” maintenance mode for critical components.

Some plants are establishing air-operated valve teams to upgrade their maintenance program to meet or exceed regulatory changes. Others have enlarged their existing valve team. A centralized valve maintenance engineer with responsibility for all plant valves might be incorporated at many plants in the near future.

4.2.1 A Holistic Approach

A dictionary defines holistic as the whole, containing all of the parts. A holistic approach could conserve many expenditures related to the maintenance of valves. A valve team leader responsible to a maintenance manager or maintenance supervisor would control a repository for all plant information on air-operated valves (or valves in

general as each particular maintenance department institutes its own program tailored to its plant requirements).

The valve team leader could maintain files on existing procedures, piping and instrumentation drawings (P&IDs), vendor manuals, work requests, work histories, and maintenance schedules. Prior to an outage or prior to a valve overhaul or test, the valve team leader could ascertain parts availability, review prior maintenance documents for problems, update procedures if required, and ensure the availability and the readiness of the labor force, work orders, scaffolding, and insulation. The valve team leader would verify clearances, ready radiation work permits, and ensure the availability of the required tools.

Immediately prior to the task, clearances should be applied for on the prime piping and prime electrical systems, as well as the ancillary piping (instrument air pilot air) and ancillary electrical distribution systems (control power and solenoid power). Obtain approval of the radiation work permit indicating proper protective clothing and radiation instruction. The rigging attachment points might require testing (I-beam clamps, and so on).

During disassembly, protect and bag the fasteners following inspection. Obtain new fasteners when required. Conduct checks to ensure that all elastomers are inspected and adverse conditions, such as hardening and cracking, are considered prior to reassembly. Thoroughly inspect all surfaces for scratches, grooves, and wear. When necessary, schedule rework and replace parts immediately to facilitate expeditious reassembly and repair.

Prior to repair, make calibrated gauges available for the valve tests in accordance with applicable codes and procedures. Check that specialized diagnostic equipment operators are available for tests to ensure the correctness and completeness of the repairs.

Transportation and cribbing might be required, in addition to rigging, to reinstall the valve. The final operational test and the cleanup of the work area should be documented for work history records.

The above sequences, under the guidance of a valve manager or team leader, can limit rework through standardization of the maintenance methods currently in use in many plants, saving valuable time and money. The above functions, however, are not all encompassing and should be reviewed by each plant.

4.3 PRE-OUTAGE WORK

4.3.1 Preparation

Whether it is an outage or only preventive maintenance during an operating cycle, the job should always be planned carefully before it actually starts. Waiting until the day of the job to start planning can be extremely costly in lost time.

If the job is large (for example, removing a main steam line stop valve), an action plan is called for. Many plants today have procedures for writing and implementing action plans. When there are multiple tasks and multiple action parties, an action plan is the clearest way to straighten out all of the expectations. The action plan is the one document that can readily cross departmental boundaries.

Planning is not easy. On a big job or a small job, there are certain things that must be done that can be defined as planning. A few of these items might need to be done several times prior to the start of the job. The following tasks should be undertaken until the responsible party is comfortable with the depth of preparation.

4.3.2 Walkdown

Possibly the most beneficial activity and one of the easiest to accomplish for the maintenance professional is the walkdown. During this walkdown, check for the clearances for ingress and egress. Verify attachment points for rigging. Note if it is a testable pad. Ensure that there is adequate and safe room for the rigger. Visualize the movement of the valve from lift to landing. Check the pathway needed to transport the valve all the way to the shop or interim staging area.

Back at the valve, check the condition of all components; look for loose parts or damaged components. Be especially alert for damaged (crimped) and loose air lines. Check the condition of the wiring to limit switches and solenoid valves. Note the actual sizes of the fasteners on the valve and the actuator. Record the nut sizes. All one-half-inch bolts do not have the same size heads. If temperature has been a problem and the plant is in operation, check the temperature in the area. If the plant is not in operation, locate the hottest (thermal) area and install a resistance temperature detector (RTD) or temperature trip to record the temperature for the next cycle.

Check all piping supports and record the instrument and valve numbers that will be used when filing for clearance. Investigate what type of insulation, scaffolding, or ladders are required to safely access the valve. Do not allow mechanics to walk or stand on the piping or electrical wiring.

A good walkdown will save many hours of additional work and will keep the problems at a manageable level. A still or video camera is very useful for job planning, especially for work in radiation areas.

4.3.3 Ordering Parts

It makes no difference whether shop spares are used or vendor parts are ordered directly; all parts must be in hand before you tear down a piece of equipment. Just verifying that they are in stores is often not adequate. Draw the parts so all can be verified for size, material, or the proper threads. Do not plan on getting vendor parts a week before the job is to be done.

If new parts are ordered and used with store room parts for the same valve, be sure that the store room parts have not changed and are still compatible with the new parts.

Shelf life should also be considered; if it is near the expiration date on elastomers (O-rings, seals, and so on), stretch one to see if it is already dried out and cracking. Have a spare for the one that gets cut during installation.

When parts are received, verify them for compatibility and conformity. Note any number differences due to vendor changes. Place a copy of the material receipt in the back of the vendor manual. Having all material available can save time and the cost of expedited parts.

Before installation, measure parts (new or stored) for proper tolerances and check mating parts for clearances that meet vendor specifications.

4.3.4 Information Gathering

As soon as you are aware of the job, obtain the appropriate (latest revision) of the P&ID and the electrical schematic. If it is an outdated issue, check it for design change packages or notices. Use these drawings to augment your walkdown to ensure that there are no unauthorized modifications and that the drawing is correct. Many delays have occurred because clearances were taken against an improper drawing.

Next, obtain the vendor manuals for the valve, actuator, and any accessory you plan on repairing or testing. Check the parts list to be sure that current parts information is available.

NOTE: Asbestos packing is no longer in use. Update vendor manuals that call for asbestos. Contact the vendor for the proper replacement.

A quick check of the elastomers against the environment and the appendixes can verify if the elastomers being used are the proper material. The proper material can save reworking the valve in an earlier-than-planned time period.

The next documents to check are the maintenance procedures. These procedures should be checked against NUREG CR-1369, *Procedures Evaluation Checklist for Maintenance, Test, and Calibration Procedures*.

Retrieve all documents regarding the maintenance history of the valve and accessories. The maintenance procedure should be reviewed and updated, if necessary, including any lessons learned during previous maintenance work.

When a valve team is being started and testing information is not readily available to establish a baseline, then the preoperational procedures can be evaluated to provide the data that is not readily available.

Know how control loops function. Gather all information required to understand the control system and develop a procedure to perform a functional test of the system.

A check of the technical specifications (on safety-related systems) will be of great benefit. Know and understand your reference material.

One of the aids most often overlooked is that of a photographic diary. A set of pictures that shows the location of all of the components and the routes for ingress and egress is suggested. A ruler should be placed in the pictures to help in indicating size and distance. These pictures are exceptionally valuable in high-radiation areas.

4.3.5 Notification (Scheduling)

The various valve jobs that are assigned come from three major sources. They might be (1) modifications, (2) routine scheduled maintenance, or (3) corrective maintenance in response to emergency shutdowns.

Modifications are routinely scheduled on a long term calendar because of budgetary constraints. These jobs are the easiest to plan because the time and resources have been allocated.

Scheduled maintenance planning and part ordering should be ongoing. Order parts six months prior to the scheduled work unless a review of the equipment indicates longer lead time for some parts. If parts with long lead time are called for, either look for a vendor that can supply the parts expeditiously or suggest a modification that will put components with parts that are readily available into the system.

Corrective maintenance that is caused by component failure cannot be scheduled; however, the trending of elastomers, service temperatures, and service cycles during predictive maintenance activities will significantly reduce this problem on extremely critical components (plant limiting).

Valve soft components—diaphragm, packing, seals, O-rings, and gaskets—should be maintained as spares. If these are to be issued beyond low bin level, the valve team leaders should be notified immediately. Remember, you are responsible for parts. You do not want to have a component failure and find that parts availability is an issue.

Routinely check the planning calendar (at least weekly). Be aware of what requirements are coming for the calendar quarter, the month, and the week. Coordinating like tasks that require common support can sometimes be very economical. Be informed and keep up to date on all work that is in progress. Inter-division work should be discussed at department planning meetings.

As an example of the above, scaffolding is to be installed to remove a failed vent fan. This same scaffolding permits access to two valves that are scheduled to be tested during the upcoming quarter. If the systems are available to test, the schedule can be modified to

permit the valves to be worked immediately, taking advantage of the prior scheduling and saving the scaffolding costs if the scaffolding meets all requirements for the job.

There are many examples of scheduling opportunities that can arise; be ready for them. In another example, two weeks prior to a scheduled shutdown, the plant trips due to a component failure (not related to the maintenance actions), and this causes the normal fueling outage to be moved ahead on the schedule. Do you lose the ability to take advantage of this valuable time? Remember, parts are your responsibility.

4.3.6 The Checklist (Tickler)

A checklist is a plus for every valve program due to the large variation of air-operated valves in a power plant. This volume of valve specifics coupled with daily routines and special projects makes it very difficult for anyone to keep all this information in their head.

A checklist is a personal planning tool and, as such, its content and format vary greatly from one checklist to another. It can contain a complete reference of the valve and its repairs. The checklist is a blend of information the user believes necessary to plan, commence, complete, and record a component repair. A sample checklist is included in Appendix I.

4.4 CORRECTIVE MAINTENANCE TASKS

The following are general maintenance procedures, practices, and precautions. Specific maintenance procedures should be obtained from the vendor's maintenance manual.

4.4.1 General Discussion

4.4.1.1 Replacement of Accessory Components versus Refurbishment

In general, there appears to be a consensus that accessories should be replaced rather than repaired. Also, OEM documentation on the repair of accessories is all but nonexistent.

The following are some of the reasons for replacing equipment rather than refurbishing it:

- The labor hours associated with refurbishing a component could easily exceed the cost of replacing it, especially if the component has to be decontaminated prior to refurbishment.
- If the component is used on or in a quality- or safety-related system, plant procedures might not allow the component to be assembled by anyone other than the OEM.
- The assembly of new components at the OEM is assumed to be accomplished using the latest parts, technology, and experienced personnel. This might not be the case in the field and might lead to an inferior product.

The above are valid reasons for throwing away used components; the following is a list of reasons to consider the alternative:

- The cost of refurbishment kits is often very low when compared to the cost of a new component.
- The learning experience of rebuilding a component is a very valuable tool in the world of diagnosing valve problems.
- Learning why a component failed can assist in preventive or predictive maintenance practices for that component. For example:
 - If a part failed because it was installed improperly, a procedure can be put in place to correct that practice.
 - If a part failed because of exposure to temperature, radiation, or some other normal environmental factors, a program can be implemented to replace that part before it reaches its useful life.
 - If a component or part is changed out because it is thought that it has reached its useful life when it really was installed improperly, a shorter than necessary predictive maintenance schedule would be assigned to that component, adding to maintenance and spare part cost.
 - It is understood that there is very little time to inspect or rework parts during an outage. Such parts could, however, be stored in an appropriate area until inspection or rework can be accomplished after the outage, thereby utilizing the labor force better during the non-outage.

It seems that whether the component is replaced or refurbished, there is an overwhelming reason to at least take the old component apart to analyze the reason for its failure or degradation. Only with this information can an effective preventative maintenance program be practiced.

4.4.1.2 Non-Metallic Parts

In general, when a non-metallic part is released from a compression force that has caused the part to set, it should be replaced. This would include diaphragms, stem seals, gaskets, and O-rings.

Parts that are torqued down and obtain a set should not be re-torqued; they should be replaced. Re-torquing could cause the material to extrude, creating more of a problem. An example of this would be an actuator diaphragm that is leaking around the flange. If it cannot be replaced right away, tighten it only enough to stop the leak and replace it as soon as possible.

4.4.2 Starting the Job (Helpful Hints)

The first step in starting a job should be the “Tailboard” or job briefing. Many plants require this as a prerequisite to large jobs. This is the time to explain to scaffold

assemblers and riggers just what your intentions are. A few questions answered now will save many delays later.

Whether you are rigging a heavy valve or performing tests with electronic instruments, unauthorized personnel should be excluded from the local area by using a caution barrier before the job actually starts. For the safety of both personnel and equipment, it is better to eliminate all through traffic.

Be sure the piping and electrical clearances are in place. If you cannot be there with the operator when he positions the valves and breakers, at least check the tags.

As the first fasteners are backed off, ensure that the piping has been vented or depressurized slowly. Clogged air line filters can be dangerous.

On electrical connections and termination boxes, check all exposed wiring for hot leads prior to working the wires and cables. Check the physical condition of all ancillary components to be sure they are firm and in the proper position. Loose parts is one of the major failure faults. After the valve or component has been removed, fasteners should be inspected and bagged (attach to the flange or take to the shop).

4.4.3 Rigging Out/In

Most riggers are extremely careful and competent, but you may want to monitor their work to ensure that no components are broken and that the air lines are not crimped. The tables in Appendix J (Valve Maintenance Clearance Data) provide suggested job planning information in relation to heavy lifts.

CAUTION: *When a heavy valve or component is free of the flanges or piping, it can swing or twist. Stand clear and beware of pinch points.*

Tie off loose piping and electrical leads in the way of component removal. This keeps air lines from being damaged and keeps electrical terminations secure.

The above list is not all inclusive. You may think of a few “Helpful Hints” yourself. Jot them down in the margin to help the next user.

4.4.4 Disassembly and Inspection

Actually, the inspection started during the walkdown when the valve was first seen for this repair order. During the walkdown, a check was made for loose and damaged parts.

The next phase is the actual disassembly of the unit. Loosen and remove each stud slowly, being cautious of any trapped fluids or leaking isolation valves. As the studs are removed and bagged, they should be checked for nicks and burrs on the threads, which could cause a faulty torque reading. Prior to reuse, they might be run down with a

dienut or coated with a very light lapping compound and chased (threaded with their own nuts). On safety-related systems, new fasteners should be checked as a set, because torquing depends on stretch. Studs of dissimilar material should not be used.

If the studs are to be re-used, they should be bagged and attached to the flange or taken to the shop with the valve.

The next inspection is that of the mating flanges. The surfaces should be checked for scoring and pitting. There is a good chance if the flange was leaking that there is a cross-surface cut that needs to be removed prior to remaking the flange. Even if there is no cut or pit, the flange can be faced with an extremely fine surfacing compound to remove surface corrosion products.

The old gasket should be saved for comparison with the new gasket. Do not install a wrong new gasket or reuse the old gasket.

The inspection of the diaphragm should be done with care. The diaphragm might be reused if the service length has been short and the environment mild (on non-safety-related valves only). The material should have good resiliency, and the part that has been clamped between the diaphragm case should not have taken a set. The diaphragm should also be checked for nicks, pits, and cracks. Replace any diaphragm that indicates these deformities.

The diaphragm can be checked carefully for minor particulate or spalling material from the piping. The presence of particulates, even in small amounts, is a good indication that your I/P transducers and solenoid valves should be checked.

If there is a rusty area or rust marks on the diaphragm it is an indication that your instrument air could be out of specification and the carbon steel piping and pressure vessels might need to be checked for pitting or corrosion. If the valves are downstream of an instrument air dryer, the dryer should also be inspected for proper operation, and the dryer towers (pressure vessels) should be checked for pitting. See Section 7.5.1 for more details on diaphragm inspection.

NOTE: *If a small micron filter has been installed in the pneumatic system upstream to the actuator assembly, the filter should be tested to check service pressure and flow rate. If both of these parameters are in specification, service the filter and continue. Many small micron filters can cause slow or no response. The attempt to clean air systems in this manner is not a proper cure. Actuator response is the more important parameter.*

Contact surfaces of valve plugs and seats can be checked for surface-to-surface contact with Prussian Blue. A full 360-degree matte-finish contact surface from lapping might be a final acceptance criteria.

All inside metal components should be checked for erosion and corrosion. Any indication of wall damage to a pressure part might require further evaluation. The results of any inspection should be recorded on the work order and on the checklist.

4.4.5 Actuator Maintenance

4.4.5.1 General Discussion

Concurrent with the valve refurbishing, the actuator and accessories are also reworked. Each of the major components will be either repaired in accordance with the manufacturer's guidelines or replaced. The proof of the repairs will be in the success of the retest and bench set.

The actuator should be disassembled in accordance with the vendor's manual. On piston actuators, the preferred method of disassembly is to replace a portion of the stay bolts with longer studs to be used as jacking bolts to relieve the force evenly. The design of the actuator dictates the length of the longer studs that need to be installed.

WARNING: *Improper disassembly or reassembly can cause serious injury. These tasks should be done only in strict compliance with the manufacturer's recommendations.*

The actuator should be completely disassembled and the parts cleaned. Sand blasting the internal diaphragm housing can eliminate rust and corrosion, but the inside must be completely free of particulates or grit prior to reassembly. All elastomers must be replaced, and sealing surfaces should present a mirror-like finish that is completely free of nicks and burrs.

The cylinder should be well greased to permit the piston-seal to travel throughout its range. The grease should maintain its lubricating qualities throughout the range of environmental temperatures that the AOV will be subjected to.

If lubricators are used, it is necessary that the solenoid vent path not be subjected to hydrocarbon vapors. This is one of the major reasons for solenoid failures.

4.4.5.2 Diaphragm Replacement Tips

- Keep the diaphragm clean. Wear clean gloves to keep deteriorating materials from coming into contact with diaphragm.
- Inspect the diaphragm for any manufacturing defects.
- When tightening the diaphragm to the diaphragm plate, do not allow the valve stem to rotate.

- Overtightening the diaphragm casing cap screws and nuts can damage the diaphragm. Use the manufacturer's recommended torque for this operation. Use a crisscross pattern to assure a proper seal.
- Once torqued, do **not** go back and re-torque after the diaphragm has set.

4.4.5.3 Stem Seal or O-Ring Replacement Tips

- Use the proper lubricant when installing the O-rings.
- When installing the stem through the stem seal, if there are exposed threads on the stem make sure that these do not cut the seals. The temporary use of Teflon tape around the exposed threads while the stem is being installed affords some protection.
- Inspect the actuator stem where it goes through the seal rings for any wear or scratches. Replace or refurbish as required.

4.4.5.4 Actuator Spring Replacement Tips

- Relieve all spring compression prior to working on the actuator.
- Do not allow the valve or actuator stem to turn during any operations.
- Lubricate all moving parts when assembling the spring.
- Adjust the spring so that it just starts to move at the lower end of the bench set pressure as recorded on the actuator name plate.

4.4.5.5 Bench Set

The last of the shop testing normally conducted is a bench set of the actuator. "Bench set" is the nameplate specification that is used to verify proper actuator operation. Bench set is expressed as the pressure range from the start of the actuator stroke to the valve's rated travel. Because actuator spring rates are not very consistent, it is reasonable to assume that only one of the bench set points can be met and the critical value should be the one adjusted. On air-to-open valves, the start pressure is critical for a valve that requires positive shutoff by the spring (that is, the seat load). On air-to-close valves, the end pressure value is critical to have enough force to overcome the spring force and the valve friction, and to seat the valve. Adjust the spring to satisfy the critical end of the stroke. The full stroke differential pressure can be changed only by replacing the actuator spring.

When conducting the bench set test, the configuration of the actuator and valve is defined by the valve manufacturer. The most common configuration is to have the actuator disconnected from the valve stem. Some manufacturers require that the packing load be removed but that the valve plug and stem remain attached to the actuator. This method accounts for the weight of the stem and valve plug in the proper operation and sizing of the valve and actuator assembly. On valve actuators that have bellows seals instead of conventional packing, the valve stem is left connected to the actuator. If there is also

conventional packing, the packing load must be relieved. The force of the bellows seal compression is significant and must be factored into the bench set of the actuator.

Because the valve forces are not present in many cases, the bench set pressure range is not the same as the pressure required to stroke the valve in actual service.

For example, assume an actuator with a load pressure range of 3 to 15 psig and a bench set of 3 to 11 psig. It is helpful to think of the loading pressure range in three distinct segments, as shown in Figure 4-1.

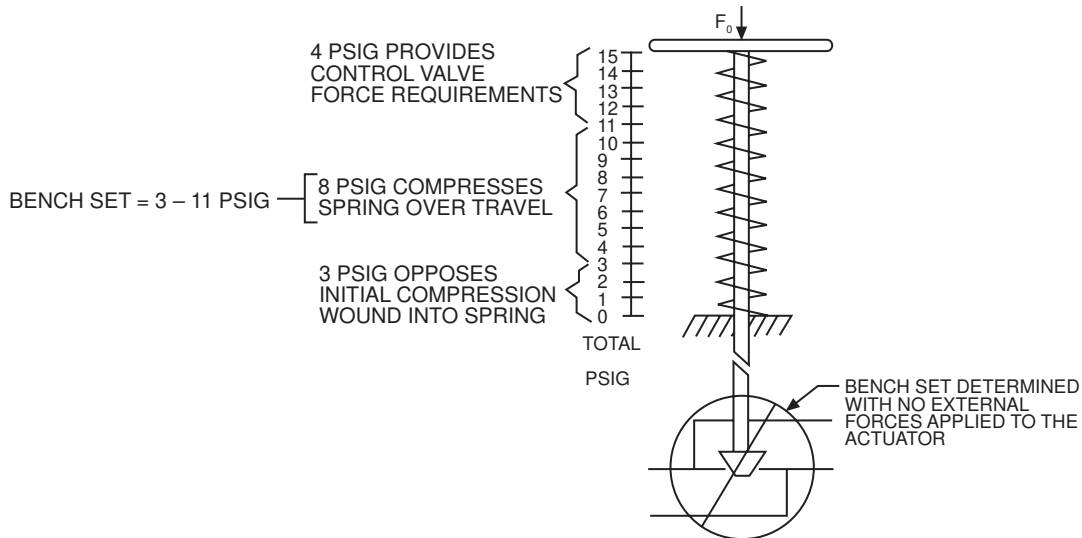

Figure 4-1
Typical Bench Set Illustrated

Figure 4-1 defines bench set and explains the process for a typical actuator that is required by the manufacturer to be disconnected from the valve stem. Plants that have active diagnostic equipment might find that their equipment supports bench set.

4.4.6 E/P or I/P Transducer Maintenance

4.4.6.1 General Mounting Suggestions

In general, E/P (voltage to pneumatic) or I/P (current to pneumatic) transducers should not be mounted on a valve that is susceptible to high vibration. The high vibration produced by some valves affects the balance bar, which converts the electric signal to a pneumatic signal.

4.4.6.2 Air Leaks and Relay Replacement

- Many air leaks, either internal or downstream from the transducer, are the major concern with transducers.

- E/P transducers or I/P transducers have integral “relays” that contain most of the non-metallic components of the transducers. These relays are easily replaced in the field and correct most of the problems with a transducer. If a transducer does not have a relay or if a replacement relay is not available, replace the complete unit.
- When replacing a relay, some type of seal goes between the main unit and the relay. Make sure that the proper (acceptable to both the original transducer manufacturer and the utility) lubricant is used on these seals, as applicable.

4.4.7 Positioner Maintenance

4.4.7.1 General Mounting Suggestions

- In general, electronic positioners (positioners that receive a current or voltage signal) should not be mounted on valves that exhibit high vibration during operation. Most of these positioners use a balance beam to convert the electronic signal to a pneumatic signal, and this beam is adversely affected by high vibrations. The corrective solution would be to mount either an I/P or E/P on a stable structure and mount a pneumatic positioner on the valve.
- Proper initial mounting of the positioner to the valve is critical to its proper operation. Most positioners are aligned to the valve while the valve is at its mid-stroke. Then the positioner is mounted and attached to the valve so that an internal cam is aligned with a follower or some other similar mechanism. If this initial mounting is not completed properly, further calibration is more difficult and proper operation might be affected.

4.4.7.2 Air Leaks and Relay Replacement

- Air leaks, either internal or downstream from the positioner, are the major concern with positioners.
- Many positioners have integral “relays” that contain most of the non-metallic components of the positioner. These relays are easily replaced in the field and correct most of the problems with a positioner. If a positioner does not have a relay or if a replacement relay is not available, replace the complete unit.
- When replacing the relay, some type of seal goes between the main unit and the relay. Make sure that the proper (acceptable to both the original positioner manufacturer and the utility) lubricant is used on these seals as applicable.

4.4.7.3 Positioner Linkage

There are two concerns with positioner linkage: linkage binding and wear of the linkage parts. Both concerns affect the control of the valve, either overall or at one location, depending on the type of wear or binding. In general, linkage has to be very free to move, with no “slop” in the linkage and no steps or wear spots in the follower linkage. Binding must be corrected so that there is free movement, and worn parts must be replaced.

4.4.8 Volume Booster Maintenance

In general, volume boosters are used to improve the response time of valves and are normally used with large volume actuators.

When used in on-off applications, the bypass restriction should be completely closed.

When used for control valve applications, the bypass restriction should be closed enough to obtain the required response from large changes in the input signal, yet allow small changes without booster operation.

Pressure regulators should be used upstream of the volume booster's supply port to protect the actuator from excess pressure if the booster should fail. The regulators should be large enough so that they do not create a restriction to the volume booster's supply.

4.4.9 Close Out

As soon as the job is complete in the field, all clearances should be removed. This needs to be done to permit an operability check of the component that was repaired or tested.

When diagnostic equipment is available, an "as-left" valve signature can be obtained.

All tools and instruments should be returned.

Scaffolding and insulation should be taken down immediately, but not before the operability checks have been satisfactorily completed.

The foreman or group supervisor should close out all paperwork. The recording of man hours expended and parts costs can be reviewed to update costs for future planning.

Finally, procedure change requests and drawing change requests should be filed in the appropriate location

5

PREVENTIVE MAINTENANCE

5.1 Introduction

This chapter provides a program for preventive maintenance (PM) tasks suitable for application to AOVs in nuclear power plants. This template was developed under EPRI Work Order 4109 under the project management of EPRI project manager John Gisclon.

5.2 AOV PM Template

PM Task	Critical		X	X	X	X	X	X	X	X	X	X	X
	Yes	No											
	Duty Cycle	High	X										
		Low											
	Service Condition	Severe	X	X									
		Mild											
Condition Monitoring													
Calibration of Accessories	See PM Rationale & Content 5.4.1		2Y	2Y	2Y	2Y	2Y	2Y	2Y	2Y	2Y	2Y	2Y
Packing Inspection/Adjustment	See PM Rationale & Content 5.4.2		2Y	2Y	2Y	2Y	2Y	2Y	2Y	2Y	2Y	2Y	2Y
Visual External Inspection	See PM Rationale & Content 5.4.3		2Y	2Y	2Y	2Y	2Y	2Y	2Y	2Y	2Y	2Y	2Y
Diagnostic Scan	See PM Rationale & Content 5.4.4		AR	AR	AR	AR	AR	AR	AR	AR	AR	AR	AR
Internal Leak Detection	See PM Rationale & Content 5.4.5		AR	AR	AR	AR	AR	AR	AR	AR	AR	AR	AR
Ultrasonic Techniques - Minimum Wall Thickness	See PM Rationale & Content 5.4.6		AR	AR	AR	AR	AR	AR	AR	AR	AR	AR	AR
Time Directed													
Air Supply Filter Replacement	See PM Rationale & Content 5.4.7		4Y	4Y	4Y	4Y	4Y	4Y	4Y	4Y	4Y	4Y	4Y
Actuator Assembly Overhaul	See PM Rationale & Content 5.4.8		5Y	6Y	5Y	6Y	5Y	6Y	5Y	6Y	5Y	6Y	5Y
Replacement of Accessories	See PM Rationale & Content 5.4.9		10Y	12Y	10Y	12Y	10Y	12Y	10Y	12Y	10Y	12Y	10Y
Valve Assembly Overhaul	See PM Rationale & Content 5.4.10		10Y	12Y	10Y	12Y	10Y	12Y	10Y	12Y	10Y	12Y	10Y
Packing Replacement	See PM Rationale & Content 5.4.11		2Y	6Y	2Y	6Y	2Y	6Y	2Y	6Y	2Y	6Y	2Y
Failure Finding													
Stroke Test (Timed Stroke, SOV, & Limit Switch Actuation)	See PM Rationale & Content 5.4.12		AR	AR	AR	AR	AR	AR	AR	AR	AR	AR	AR

Template Definitions:

Refer to specific rationale and content for each PM task.
 AR - As Required. See Note 6 for additional information.
 NR - Not Recommended.
 Y - Years.

5.3 Template Notes

NOTE 1: Use of Template Intervals

The Expert Panel felt there was sufficient cause to perform the tasks as close as possible to the intervals indicated in the template unless specific means are employed to add confidence that a more extended interval can be used (for example, insertion of a visual inspection [see note 6] or the use of condition monitoring, maintenance history, and as-found conditions).

Deferral of any overhaul task requires an evaluation. One evaluation method would be to compare, using a sampling process, the candidate equipment's maintenance history and as-found conditions to those of other components with similar specifications and operating conditions.

NOTE 2: Service Conditions

If the component operates in severe service conditions, the plant-specific conditions must be considered in order to select appropriate intervals.

NOTE 3: Run-To-Failure

If there are plant-specific conditions (that is, one or more columns) for which no PM task is appropriate (NR for all tasks in that column), this is considered to be Run-To-Failure (RTF). RTF is a maintenance-only option for those always non-critical components that meet *all* the following conditions:

- The component is not required for vital system redundancy.
- The component's failure does not promote failure of other components.
- There is no increased personnel radiation exposure if the component is run-to-failure.
- It is more cost-effective to repair or replace the component rather than to maintain it.
- There is no simple cost-effective task to maintain the component.

NOTE 4: Post-Maintenance Test

After completion of any action that could affect component function, it is prudent to verify that the component operates in an acceptable manner (that is, by post-maintenance testing), whether or not this is required by applicable regulations. Consequently, post-maintenance test activities are not described explicitly in this report. It should be noted that the tests described are in addition to post-maintenance testing.

NOTE 5: Regulatory Requirements

Existing Technical Specifications and other regulatory requirements (for example, ASME Section XI) should always be followed. If the above recommendations differ from these regulations, the more conservative approach should be followed. Appropriate task interval determination could lead to recommendations for intervals that differ from the existing regulations. In such cases, there might be a basis for seeking changes to the regulations.

NOTE 6: Scheduling of Related Tasks

In general, evidence of abnormal degradation obtained from visual inspections can be evidence that overhaul task intervals need to be adjusted. This is why we do visual inspection.

Visual inspection is typically performed to ensure that critical components in severe service conditions (for example, high temperatures, high humidity, or salt laden air) can reach the prescribed detailed inspection and overhaul intervals.

In more normal service conditions for critical components, visual inspection can be combined with overhaul to provide flexibility when the overhaul is performed.

The intervals in the template and the discussion above on the task scheduling assume that after the overhaul, whenever it occurs, the schedule is repeated as if starting from zero. Consequently, the schedules for any particular time-directed tasks do not continuously repeat because they are closely related to the schedules of the other time-directed tasks and the occurrence of the overhaul, in effect, resets the schedule clock.

NOTE 7: Scheduling for Related Components

The task intervals are specific for the component in order to address the technical basis for the task. When the component has preventive maintenance performed in conjunction with another component type (for example, motor and pump), some compromises on task intervals might be necessary to meet scheduling demands. Normally, the compromise would choose the shorter interval. These decisions will depend on the particular combinations of components at each utility. It is recommended that separate “skid templates” be developed by the utility for these situations.

5.4 PM Rationale and Content:

5.4.1 Calibration of Accessories

Calibration measures the dynamic response of individual accessories (for example, E/P, positioner, booster) to a control input. The intent is to ensure that each accessory is functioning correctly within design tolerances (for example, start and stop points, travel, timing). Calibration thus focuses on the design specifications of the accessories. It

provides assurance that the process is being controlled properly, at least as far as the inputs to the actuator and valve are concerned.

Calibrations are useful in providing information on accessory condition. Persistent, significant calibration drifts can be used to identify the need for accessory replacement. No other information might be available for this purpose as it is not cost-effective to internally examine the condition of accessories.

Valve or operator internal degradation can occasionally be inferred from calibration data, but not with any precision as to its location or quantification of the degradation mechanism. It is more likely that persistent accessory drift might suggest the potential for internal damage to the valve and would be factored into the decision process to investigate further. For example, calibration drifts that suggest a valve has been improperly seating over an extended period could raise the question of erosion of the seat. Timely correction of calibration drifts is therefore important in preventing degradation of internals.

Trended accessory calibration data should be used as justification to adjust PM frequencies. This could consist of as-found and as-left data on I/P (E/P) and positioners. EPRI report *Guidelines for Instrument Calibration Extension/Reduction Programs*, TR-103335, can be useful in determining appropriate intervals based on historical as-found/as-left calibration data. Other factors, such as duty cycle, can influence the interval decision.

Calibration should include:

- Set limit switches
- Pressure regulator set point
- I/P or E/P transducer
- Positioner
- Booster tuning
- Pressure switches

5.4.2 Packing—Inspection and Adjustment

Inspect for unacceptable leakage from the packing area and adjust the gland nut torque according to site procedures.

5.4.3 Visual External Inspection

A visual external inspection is performed because it is a quick, non-intrusive, and inexpensive way to detect obvious signs of some developing problems. Such an inspection does nothing to ensure that the equipment is working properly, but it does provide detection of many degraded conditions that are visible or quickly detectable (for example, using a soap bubble test) from outside the valve. Items that can be detected by external visual inspection are listed below. Inspection of the packing area, with adjustment of the packing only if necessary, is a type of visual inspection.

A visual inspection should include:

- Structural integrity
- Subcomponent damage
- Loose, broken, missing fasteners, especially in high vibration areas
- Damaged or loose electrical connections
- Air leakage from pneumatic components
- Process leakage inspection (for example, soap bubble check) to include packing area, body to bonnet area, flange joints, leak off lines, and pressure boundary
- Actuator shaft condition
- Condition of the valve stem and stem nut connector
- Pneumatic pressure readings within expected ranges

It is recommended that an informal external inspection should be performed every time cognizant persons are at the valve. Such informal inspections should not replace the scheduled inspection.

5.4.4 Diagnostic Scan

Diagnostic scans check the operability of all the accessories, the actuator, and the valve as a single integrated unit. As a minimum, they provide a verification of the calibration data and the calibration process. This verification includes being within overall tolerances for the complete valve as a system.

Diagnostic scans include dynamic measurement of travel, total friction, air pressures, spring rate, and seat load. When combined with acoustic and thermographic internal leak detection, these measurements provide detection, location, and quantification of most sources of internal degradation. For example, if valve timing or travel data indicate a problem, the diagnostic scan can usually indicate if the source is inappropriate friction, possibly from a packing problem or internal damage, or if it is a result of worn springs.

Travel and seat load information on the seating area can raise the likelihood of internal leakage, which can often be confirmed by acoustic or thermographic techniques. There are limits to these capabilities. For example, although leakage can be confirmed, the extent of the leakage can be assessed only by an inspection of the seat, that is, an overhaul. The techniques may not always be applicable. For example, a cold water valve in a noisy environment might not be assessable by thermography or acoustics. A control valve that needs to shut off in an emergency might not be able to be tested for leakage in realistic shut-off conditions.

Nevertheless, a diagnostic scan can be used to decide if the source of a problem is the operator or the valve, and whether the problem can be corrected without tearing down the whole valve.

Because the diagnostic data can be trended, it is possible to use it, with some qualification, to defer overhauls and replacements when the condition of the equipment appears to be good and stable over time or to decide if an overhaul is appropriate. However, there is one major exception to this claim. Diagnostic scans do not provide information on the condition of the diaphragm. The condition of other soft goods can be inferred from diagnostic information because they typically deteriorate gradually and give signs of progressive leakage. For example, O-ring piston seals degrade this way. Similarly, soft goods in accessories typically show degradation over time through increasing calibration drift, as mentioned above.

The inability to detect diaphragm degradation using diagnostic techniques is the main factor leading to the need for overhauls for valve actuators.

Current data acquisition packages can record and permit trending of useful valve parameters. These parameters can include travel, total friction, air pressures, spring rate, seat load, and so on, and can be used to adjust PM intervals. Suggested intervals are 2 years for high duty cycle valves and 4 years for low duty cycle valves, with the qualification that limits on the use of diagnostic resources will probably require doing diagnostic scans on a revolving basis. For example, 25% of the high duty cycle valves could be scanned each outage so that every valve is covered in four outages.

A diagnostic scan should include:

- Friction
- Seat load
- Travel
- Available actuator thrust
- Accessory signatures

5.4.5 Internal Leak Detection

Advanced technologies, that is, temperature profile and acoustic signature, can be used for non-intrusive internal leakage detection. They also can be used for detection of external leakage paths while being used for internal leakage detection.

Internal leak detection on the valve seat should include:

- Acoustic and infrared techniques
- Seat leakage
- Damaged or degraded electrical connections (Recommended while thermographic equipment is at the valve site.)

Internal leak detection for pneumatic leakage should include:

- Acoustic techniques
- Actuator air leakage
- Accessory component air leakage

5.4.6 Ultrasonic Techniques—Minimum Wall Thickness

ASME Section XI requirements include this task for many valves. This can also be used on valves that are susceptible to erosion, corrosion, or other severe service conditions (cavitation, flashing, Microbiologically Induced Corrosion, and so on) typically found in raw water service or steam service.

5.4.7 Air Supply Filter Replacement

Because repair or refurbishment of the air filters is not cost-effective, the PM task is to replace them. Air supply system quality and cleanliness can also affect valve function and operation. A general air supply system check is prudent in conjunction with this replacement activity; problems in the air supply could result in shorter intervals.

This task should include:

- Replacement of the air supply filter

General inspection of the air supply system for cleanliness and operability should include:

- Excessive moisture
- Oil contamination
- Debris
- Restrictions
- Leaks
- Acceptable air pressure
- General damage

5.4.8 Actuator Assembly Overhaul

The main rationale for overhauling the actuator on a regular schedule is to replace the soft goods because they degrade with age and exposure to the service environment. The result is that replacement of the diaphragm, in particular, is necessary if failures are to be prevented in some service environments. This would normally be the case for trip-critical valves or valves that are extremely risk-significant. The actuators for such valves are thus never likely to be maintained on a 100% condition basis unless the diaphragms are made of a material suitable for the valves' environment.

Soft goods, including the diaphragm, are expected to possess a characteristic service life, even though this can be a complex function of application, service environment, and duty cycle. It is, therefore, in principle possible to replace soft goods “just in time.” Finding the right time without discarding a significant amount of useful life and without experiencing a significant number of failures should be a major objective for the most critical applications.

Because degradation of the soft goods is expected to depend in a specific way on service conditions (for example, temperature, radiation), duty cycle, and the application (for example, position-sensitive vibration levels), significant differences in degradation rates among actuators should be investigated. Correlation of the degradation rates with these factors might lead to some actuators being permitted longer intervals between overhauls than others. In these cases, reliability should be improved by the use of longer intervals.

Actuator assembly overhaul should also include both an internal and external inspection. During these inspections, it is also prudent to verify the cleanliness of the air supply system. Lubrication is not performed as a regular separate PM for air-operated valves. Certain subcomponents will receive lubrication as part of normal overhaul activities. The overhaul and inspection activities should contain the following minimum set of activities:

5.4.8.1 Actuator assembly overhaul:

- Replace soft goods, for example, gaskets, packing, diaphragms, seals, and so on
- Replace or repair hardware, as required
- Clean or refurbish seal surfaces

5.4.8.2 Actuator assembly internal inspection for the condition of, or for damaged or missing:

- Sealing surface
- Bushings
- Sealing components, for example, diaphragm, seals, O-rings, and so on
- Cylinder walls and piston, if applicable
- Stem
- Gearing
- Springs
- Vents (are they clear?)
- System cleanliness

5.4.8.3 Actuator assembly external visual for the condition of, or for damaged or missing:

- Structural integrity
- Subcomponent damage
- Fasteners that might be loose, especially in high vibration areas
- Connections, for example, electrical, pneumatic, and so on
- Valve stem
- Check for correct pressure gauge readings prior to overhaul and before return to service
- Check for fluid or air leaks
- Manual operator is not engaged

5.4.9 Replacement of Accessories

Accessory replacement is motivated mostly by the need to address worn out or degraded soft goods within each accessory device or component. Deterioration of soft goods and also mechanical wear both lead to symptoms observable in diagnostics or to some degree by calibration drift.

Because repair or refurbishment is not usually cost-effective for accessories, the recommended PM task is to replace them. Even though the removed accessories are not refurbished, a sample should be inspected for degradation that may indicate a need to adjust the current replacement interval. If calibration data is trended, it can serve to show that the replacement interval should be adjusted.

Wearout of accessories is expected to be application (for example, vibration), duty cycle, and service condition related so that optimal replacement times might vary significantly from one group of valves to another. Replacement is preferred over refurbishment due to cost and time constraints. Individual accessory items might require different replacement intervals. Replacements should take into account the date of the previous actuator accessory replacement.

The replacement of accessories should include:

- Solenoid valves
- Positioners
- Regulators
- I/P and E/P transducers
- Boosters
- Limit switches
- Pressure switches

5.4.10 Valve Assembly Overhaul

The rationale for a regular, scheduled overhaul of the valve body is not as clear as in the case of the actuator. The soft goods in the valve (for example, packing, gaskets) degrade over time, but all the degradation modes of the soft goods show manageable symptoms that can be detected through diagnostic scans (for example, friction) or visual inspections (for example, leakage).

Stem and trim condition (for example, seating) can be inferred by diagnostics to detect leakage, although an inspection is needed to assess the amount of leakby and the extent of damage to the seat. Ultrasonics is regularly used to detect wall thinning.

Ultimately, an overhaul might be indicated to reduce leakage, to address packing deterioration that is not correctable by retorquing, to replace or refurbish trim, and to replace gaskets.

In general, catastrophic failure without previous warning is very unlikely, so that the valve body assembly is a good candidate for maintenance through a 100% condition-based program. However, if a utility's diagnostic capability is weak, there might still be a need for regular valve body overhauls for the critical valves. The intervals in the template can be used for this situation or for beginning the transition to an entirely condition-based program. In achieving this optimum, information on valve internal condition from internal inspections performed during overhauls will be indispensable. It is recommended that the goal should be to eventually not have regular intervals for the valve body assemblies.

Valve assembly overhaul should also include both an internal and external inspection. The overhaul and inspection activities should contain the following minimum set of activities:

5.4.10.1 Valve assembly overhaul:

- Replace soft goods, for example, gaskets, packing, diaphragms, seals, etc.
- Replace or repair hardware, as required
- Clean or refurbish seal surfaces

5.4.10.2 Valve assembly internal inspection for the condition of, or for damaged or missing:

- Body for erosion, wear, and so on
- Trim for erosion, wear, and so on
- Sealing surfaces, for example, gaskets, and so on
- Stem
- Stuffing box
- Bearing surfaces

- Bolting or stud holes
- Body porosity
- System cleanliness

5.4.10.3 Valve assembly external visual inspection for the condition of, or for damaged or missing:

- Structural integrity
- Subcomponent damage
- Fasteners that might be loose, especially in high vibration areas
- Electrical connections
- Valve stem
- Check for correct pressure gauge readings prior to overhaul and before return to service
- Check for fluid or air leaks
- Manual operator is not engaged

5.4.11 Packing Replacement

Packing deteriorates over time and is expected to leak progressively. Replacement of the packing is performed when retorquing no longer is feasible. Consult your packing program or station procedures for trending and interval modification. If no packing program exists, use the suggested intervals in the table, which are timed to coincide with actuator overhauls.

- Replacement and inspection of packing should include:
- Replace the packing
- Inspect the stem
- Inspect the gland follower
- Inspect the studs/nuts
- Inspect the stuffing box conditions

5.4.12 Stroke Test—Timed Stroke, SOV, and Limit Switch Actuations

A stroke test, timed or not, is done to verify operability of the valve as a complete unit, including the solenoid-operated valve. A simple stroke test can be done as a failure-finding task to ensure that a valve has not already failed; however, it provides practically no assurance that the valve is not about to fail. A timed stroke test, combined with the visual external inspection, provides additional assurance that the valve system is operating within overall tolerance, especially if the data is trended over time. These tasks are embodied in ASME Section XI and other standards. A time response outside

tolerance requires further diagnostic investigation to ascertain whether the problem is in the valve or the actuator. Failure finding tasks, such as stroke tests, can be applied to any critical valve that might fail undetected.

Stroke tests should include:

- Timed stroke
ASME Section XI. Timed stroke tests can identify sticking or other valve malfunction and can also be applied to valves not within the purview of ASME Section XI.
- Limit switch actuations
- SOV actuations

5.5 Examples of Valves Satisfying Template Conditions

Critical Valve	Feedwater regulator
High Duty Cycle	Pressurizer spray
Severe Service Condition	Charging and let down flow control High pressure injection (PWRs)
Critical Valve	Power-operated relief valve
Low Duty Cycle	Condenser bypass
Severe Service Condition	Main steam bypass Heater drain (alternate/emergency) dump Containment isolation (inside containment) Sample valves
Critical Valve	Heater drain flow control
High Duty Cycle	Main steam relief
Mild Service Condition	Condensate
Critical Valve	Service water (cooling)
Low Duty Cycle	Component cooling water
Mild Service Condition	Circulating cooling water Fire protection
Non Critical Valve	Plant Heating
All Duty Cycle	Water Treatment
All Service Condition	Sewage System Service Air

5.6 Definitions of Template Application Conditions:

5.6.1 Critical

- Yes** Functionally important, for example, risk significant, required for power production; safety related, high radiation exposure during repair, or other regulatory requirements.
- No** Functionally not important, but economically important, for example, for any of the following reasons: high frequency of resulting corrective maintenance, more expensive to replace than to repair, high potential to cause the failure of other critical or economically important equipment.

5.6.2 Duty Cycle

- High** Operates frequently, for example, used for control of process flow
- Low** Operates very infrequently, for example, used for open or close

5.6.3 Service Condition

- Severe** Exposed to environments (internal and external to the component) or to process fluids, that adversely affect reliability; internally or externally subjected to high temperature, temperature swings, rain, spray, freezing, chemicals, dust, or high radiation; passes corrosive fluids.
- Mild** All other conditions

6

DATA ACQUISITION AND DIAGNOSTICS

6.1 INTRODUCTION

The introduction of air-operated valve (AOV) Data Acquisition Systems and AOV diagnostics has piqued the interest of utilities throughout the industry. This chapter describes how Data Acquisition Systems operate and how they can be applied, reviews some basic calibration and diagnostic techniques, and discusses the benefits that can be obtained from these systems. Appendix C presents typical problem traces and discusses theory on the basic calculations and generic information that might be used to assist the utility in starting or adding to its AOV program.

The following definitions were obtained from *The American Heritage Dictionary of the English Language*:

Data	plural noun (used with a sing. or pl. verb) (1) Factual information, especially information organized for analysis or used to reason or make decisions. (2) (Computer Science) Numerical or other information represented in a form suitable for processing by computer. (3) Values derived from scientific experiments. (4) Plural of DATUM.
Acquisition	noun (1) The act of acquiring.
Diagnostic	adjective (1) Of, relating to, or used in a diagnosis. (2) Serving to identify a particular disease; characteristic.
Diagnosis	noun (1) Often diagnostics. (used with a sing. verb) The art or practice of medical diagnosis. (2) A symptom or a distinguishing feature serving as supporting evidence in a diagnosis. (3) An instrument or a technique used in medical diagnosis.
Diagnosis	noun (1) (Medicine) (a) The act or process of identifying or determining the nature and cause of a disease or injury through evaluation of patient history, examination, and review of laboratory data. (b) The opinion derived from such an evaluation. (2) (a) A critical analysis of the nature of something. (b) The conclusion reached by such analysis.

From the above, a Data Acquisition System can be defined as a system used to acquire information for the purpose of discussion, calculations, or diagnosis. For the purpose of clarification in this section, the equipment used to obtain the information will be called

the Data Acquisition System and the process of analyzing the data to resolve a problem will be classified as diagnosis. Although some of the Data Acquisition Systems do perform calculations (that is, they record data and calculate the bench set or friction), this process will be considered calculation, not diagnosis.

Maintenance groups have been acquiring data and diagnosing problems, probably since the advent of the first power-actuated valve. They have been using pressure gauges and scales, inputting control signals, recording information, and evaluating the information to compare it to some known baseline. They have also been using such tools as thumb-nails to sense when a valve starts to move and to determine if the valve is moving smoothly. Although this method has been working for years, it lacks consistency and might not be accurate enough when working with today's more complex and more efficient plant systems.

AOV Data Acquisition Systems are micro-computer-based systems that are specifically designed to automate AOV data acquisition. They can be used to calibrate AOV components and subsystems, verify conformance with design basis, accurately determine component hysteresis (action lag behind signal input) and stroke time, locally control the valve for testing, store and retrieve historical performance information, document post maintenance testing, and be used, if not to specifically diagnose a problem, at least to pinpoint the area of a problem or eliminate components as the cause of a problem. The major advantage of Data Acquisition Systems is their ability to record data in a consistent and accurate manner. Most of these capabilities can significantly reduce maintenance costs and person hours.

However, not all of the AOV Data Acquisition Systems have all of the capabilities described in this section, and there are a number of different methods that are used to obtain and analyze the data acquired. At the present time, the calculation capability, if available at all, is limited to a few parameters and ultimately leaves the final diagnosis up to the valve analyst.

6.2 MANUAL CALIBRATION VERSUS DATA ACQUISITION SYSTEM CALIBRATION

Manual calibration of a positioner or an I/P or E/P transducer is a person feeding in a control signal to the component and adjusting the zero and span on the component until the desired output is obtained. To do this, the valve technician uses a control signal input, either electronic or pneumatic; a calibrated pressure gauge; a scale to determine the full stroke; and, in many cases, the thumbnail to determine when the valve comes off its seat.

If a Data Acquisition System is used, the system can input the control signal and the results can be read directly from the system, including a very accurate position indication. The zero and span still have to be manually adjusted, but now the control signal can be dialed in and the output read from the Data Acquisition System. After the desired results are obtained, the Data Acquisition System can be used to supply a dynamic signal to the component, record the data, and use that data to determine how the valve calibration looks under dynamic conditions.

6.3 DATA ACQUISITION SYSTEM OPERATION

This guide provides technical descriptions of valves, actuators, I/Ps, and positioners. Much of the setup associated with these components has, in the past, been done manually by the valve technician. Conducting a bench set on an actuator or calibrating a positioner are tasks that, in order to be performed correctly, require little in the way of additional equipment but require highly trained valve technicians.

With the assistance of an AOV Data Acquisition System, the job can be done more quickly, more accurately, and with repeatability, while providing information concerning other aspects of the valve's operation. AOV Data Acquisition Systems measure parameters from the valve and actuator and use a computer program to assist the system operator in analyzing this data, ultimately providing additional insight into the valve's performance.

6.3.1 Parameters To Be Measured

Figures 6-1 and 6-2 show a typical control valve and an on-off or isolation valve, respectively, with various parameters labeled. Key parameters that are dynamically measured are described below.

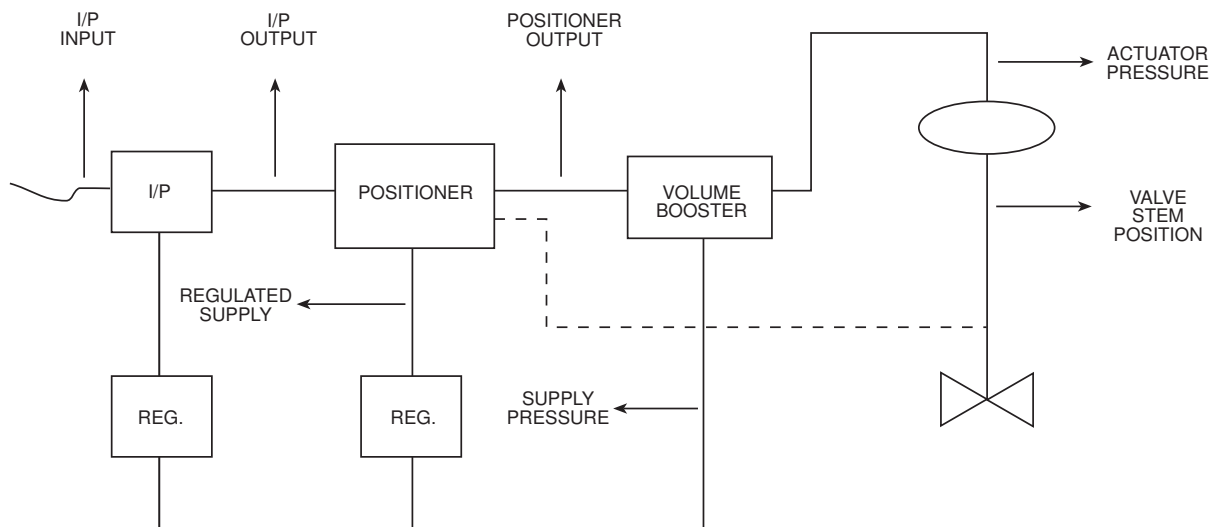

Figure 6-1
Typical Control Valve's Measured Parameters

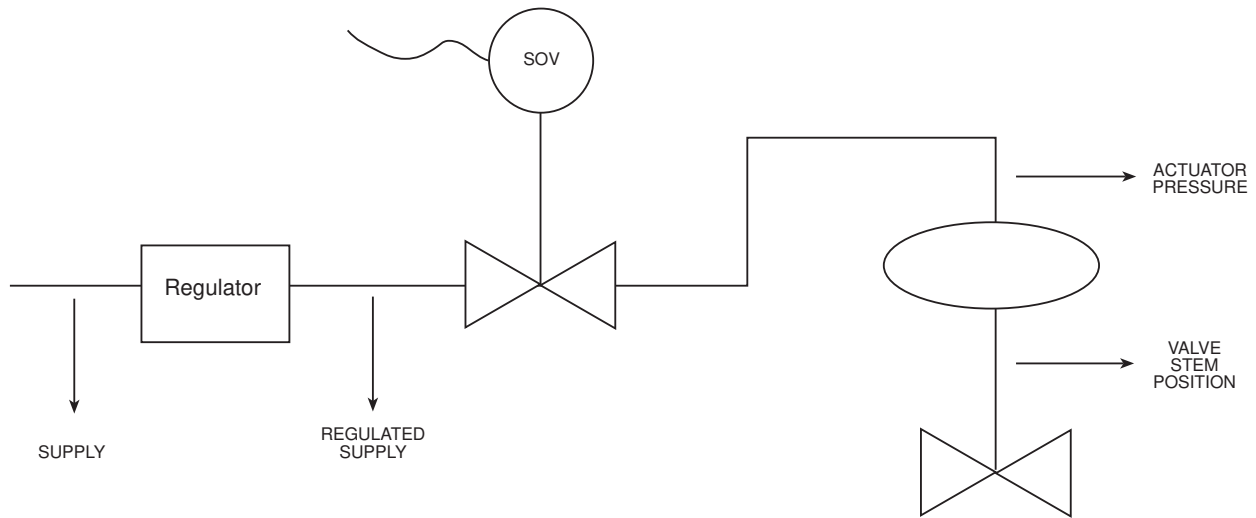

Figure 6-2
Typical On-Off or Isolation Valve Measured Parameters

Supply Air Pressure: The supply air is the working medium to control the valve’s position. Depending on the valve requirements, both the supply pressure and the capability of the system to supply a sufficient volume of air are critical to ensure proper operation of the valve. The supply pressure can either be straight from the compressed air system or regulated to protect some of the valve’s components. If the air supply is regulated, the term then is *regulated air pressure*. Typically, only the regulated air supply is measured unless there is a suspected problem with the regulator or the upstream piping, in which case both parameters might be measured to confirm the problem.

This parameter is measured during the whole valve stroke to ensure that pressure is maintained. Air line restrictions would indicate normal pressure during steady state conditions, but when a demand is placed on the supply, system pressure would drop, depending on the load. This can affect valve stroking time.

Control Signal: The control signal can be either a pneumatic or an electrical signal. These signals are measured and/or controlled by the Data Acquisition System. The control signal is the required position requested by the controller.

For clarification, a current signal is designated with an “I” while a voltage signal is designated with an “E.” For example, a current-to-pneumatic transducer is either called an I/P transducer or simply an I/P, and a voltage-to-pneumatic transducer, one receiving a 0 to 10 volt signal, is called an E/P transducer or simply an E/P.

The control signal is typically controlled by the Data Acquisition System to allow a fully controlled stroke of the valve. This allows verification of the valve’s operation with a known controlling signal. The control signal is typically input into the I/P (I/P Input) or the positioner (Positioner Input).

Actuator Pressure: The positioner or solenoid provides a pressure/volume of air to the actuator, depending on the demand requirements of the system. By comparing the actuator pressure with the positioner output, actuator problems such as diaphragm or seal leaks can be detected. The actuator pressure enables the valve analyst to calculate stem forces, and when compared to stem position, the spring rate can also be calculated.

Valve Stem Position: This parameter is typically measured with a linear variable differential transformer (LVDT), a laser, or a linear potentiometer (sometimes called a string pot). Stem position provides positive verification that the valve is moving with the applied pressure from the positioner. The valve's total stroke time can also be determined from this measurement.

Other parameters that can be measured to determine AOV information are:

Strain: In the stem or yoke, stress can be used to obtain the valve body internal forces, such as the packing friction and seating force. This measurement can be used to differentiate actuator forces from valve forces or actuator problems from valve internal problems.

Solenoid-Operated Valve (SOV) Activation: Using current, voltage or induction measurement methods, the exact time that an SOV was activated might be useful in determining stroke timing, a sticky SOV, or a pilot that is not transferring (shuttling) completely.

Auxiliary Pneumatic Components: Measuring the input and output of auxiliary components, such as volume boosters or lock-up valves, can be useful in determining the component's health or its effect on the valve's operation.

Some of the AOV Data Acquisition Systems have the capability of measuring a wide range of other parameters that might be useful in determining a system-related problem rather than a pure valve problem. For example, system pressure or flow might be useful in determining if the system, and not the valve, is causing the problem.

6.3.2 Testing Sequence

A typical testing sequence might be as follows:

6.3.2.1 Step Open and Step Closed Test

This would be used to determine the stroke time of the valve and which components restrict the valve's movement. For example, if the air pressure upstream of the positioner drops significantly, this would be an indication that the upstream supply components, such as tubing, piping, or a regulator, were creating some type of restriction. These are referred to as "Step" tests, rather than "Quick Open" or "Quick Closed" tests, to distinguish them from the safety function that some valves have to perform.

6.3.2.2 Slow Ramp Test

Typically, a slow ramp is a ramp from full closed to full open, and includes a return to the full closed position. The timing of these excursions is typically three to ten times the maximum length of time that it took the valve to either open or close in the Step Open and Step Closed Test above. For example, if it took a valve seven seconds to go from its closed position to its open position in the Step Open and Step Closed Test, the ramp time in each direction should be anywhere from 21 to 70 seconds.

$3 * 7 \text{ seconds} = 21 \text{ seconds (Shorter Ramp)}$

$10 * 7 \text{ seconds} = 70 \text{ seconds (Longer Ramp)}$

Both are part of the Slow Ramp Test.

The purpose of the slow ramp is to allow the valve to approach its steady state condition as it is moving along dynamically. It also eliminates or greatly reduces pressure drops and venturi effects in the air tubing and test Tees, thus enabling accurate pressure readings. The shorter ramp works out very well strictly for isolation valves. In control valves, the longer ramps are necessary to obtain good data about the positioner. For valves with high capacity positioners, volume boosters, or large actuators, these times might not be long enough to reach the "steady state" point. The objective is to run the fastest ramp rate that will provide a dynamic error trace that can be duplicated in slower ramp tests.

Another technique used during the slow ramp is to over-range the input control signal to make sure that the valve gets to both end points. For example, if the valve is normally driven with a 4 to 20 mA signal, a 2 to 22 mA signal or a 3 to 21 mA signal would be sent to the positioner or I/P, so if the valve was not calibrated, the end points would still be reached. It is important to get to the end points to obtain more accurate information and to determine if the valve is truly seating or back seating.

6.4 GRAPHICAL ANALYSIS

With the above parameters recorded and the above tests run, the data can be used to separate specific components and/or attributes of the valve assembly. This separation is probably the most valuable outcome of the Data Acquisition Systems. Because of this, the I/P, the positioner, or the mechanics of the valve and actuator assembly can be looked at as separate and distinct components. With one set of tests, a problem with the I/P can be isolated, and it can be determined that neither the positioner nor the valve mechanics are a part of the problem. The following table provides an overview of what test to run and what parameters to review to obtain specific information about the valve and components.

Table 6-1
Overview of Graphic Analysis

Type of Test	Diagnostic Information	Type of Plot	Suggested Parameters to Plot
Step Open and Step Closed	Overall Valve Response	Component Response	Time vs. Controls Signal Input & Stroke
	I/P or E/P Response		Time vs. I/P Input & Output
	Positioner Response		Time vs. Positioner Input & Stroke
	Air Leakage/Losses		Time vs. Air Pressure
	Adequate Air Supply		Time vs. Supply or Regulated Air Pressure
Slow Ramp	Overall Calibration (Zero, Span, Dynamic Hysteresis plus Dead Band and Linearity)	Overall Calibration	Input Signal vs. Stroke
	I/P or E/P Calibration (Zero, Span, Dynamic Hysteresis plus Dead Band and Linearity)	Transducer Calibration	Input Signal vs. Transducer Output Pressure
	Positioner Calibration (Zero, Span, Dynamic Hysteresis plus Dead Band and Linearity)	Positioner Calibration	Input Signal to the Positioner vs. Stroke
	Total Friction	Mechanical Properties	Stroke vs. Actuator Pressure or Force
	Spring Rate		
	Approximate Bench Set		
	Seat Load		
	Margin to Open		
	Spring Linearity		
Actuator and Valve Friction	Stroke vs. Actuator Pressure Force and Stem or Yoke Strain Force		

6.4.1 Evaluation from Step Open and Step Closed Testing

Looking at each parameter versus time during the Step Open and Step Closed Test indicates if the supply or regulated air pressure is being restricted, or if the positioner, SOV, or volume booster could be a problem with slow valve response. This plot might also reveal mechanical problems such as a plug sticking in its seat, or jerky stem movement. Whatever the problem is with regard to slow valve response, this plot can either eliminate components, point to a component, or indicate that a component needs further investigation. A typical graphic representation of a Step Open and Step Closed Test is presented in Figure 6-3.

In this air-to-close valve, the time to open, as measured from the time the control signal started to decrease, was 55.5 seconds. As can be seen further along on the figure, it took 6.5 seconds to close. It can also be observed that the supply pressure dropped only about 5 pounds during the highest demand period.

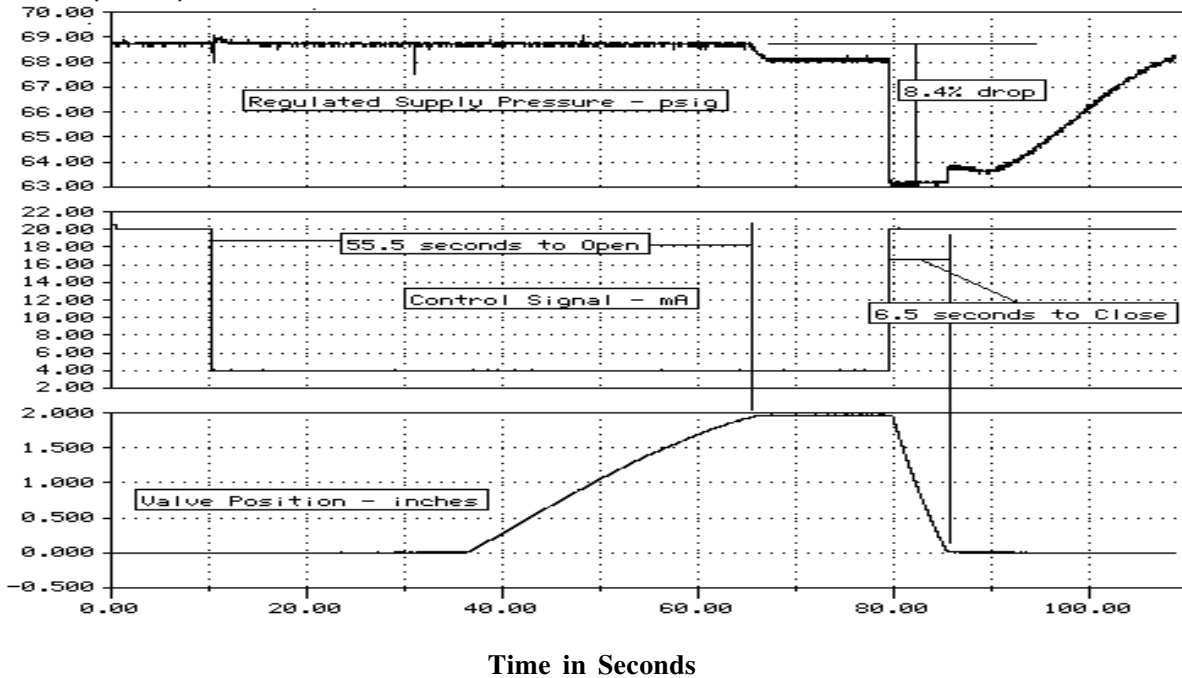

Figure 6-3
Overall Valve and Component Responsiveness

The response rate of an I/P transducer (how fast the output pressure responds to a step change in the input signal) can also be evaluated during the Step Open and Step Closed Test. When compared to a properly operating I/P, a slow responding increasing pressure output might indicate a problem in the I/P or might indicate a leaking air line. A typical I/P response to an increasing input signal is presented in Figure 6-3A, while Figure 6-3B presents the decreasing. The overall response time for the I/P to reach the 3 psig output signal is 0.62 seconds from the time the input signal first starts to decrease.

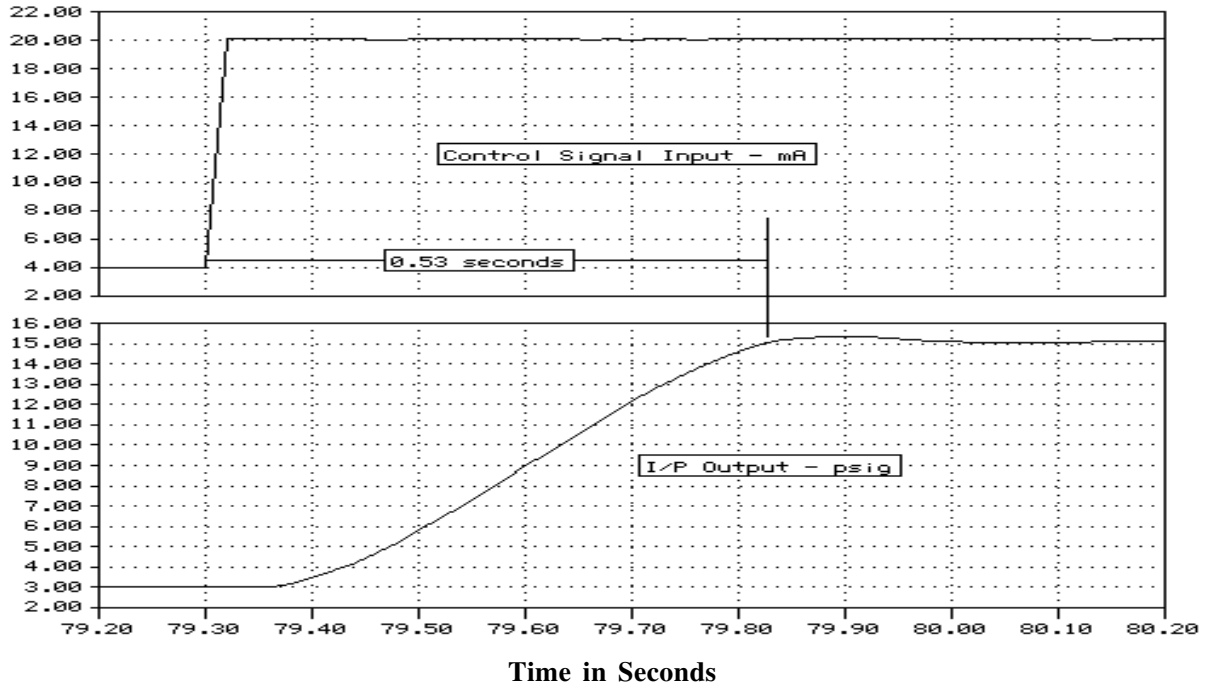

Figure 6-3A
I/P Response to Increasing Signal

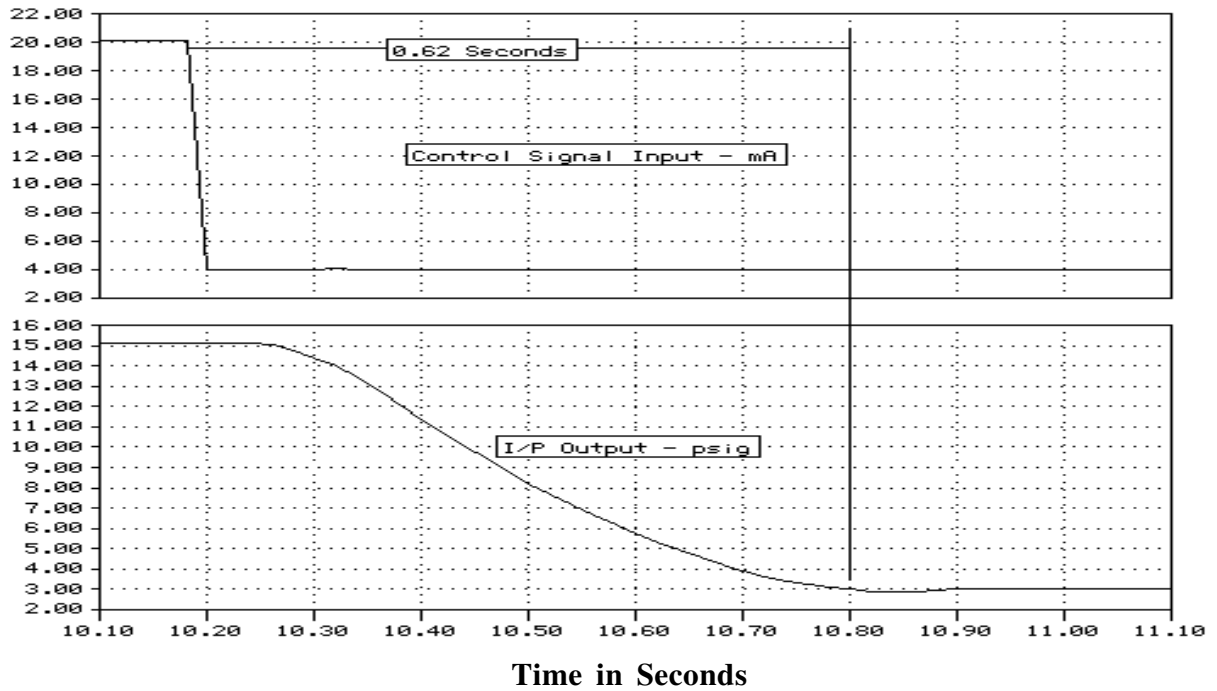

Figure 6-3B
I/P Response to Decreasing Signal

6.4.2 Evaluation from Slow Ramp Testing

From the Slow Ramp Testing, two cross plots can provide all the significant information to evaluate either the valve's mechanical properties or the calibration of the components. These plots are described in the section that follows.

6.4.2.1 Mechanical Properties of the Valve and Actuator

Plotting the actuator pressure or differential pressure (across a double-acting actuator) versus the valve stroke provides all the mechanical attributes of the valve and actuator assembly. This plot uses the data obtained during the Slow Ramp Test.

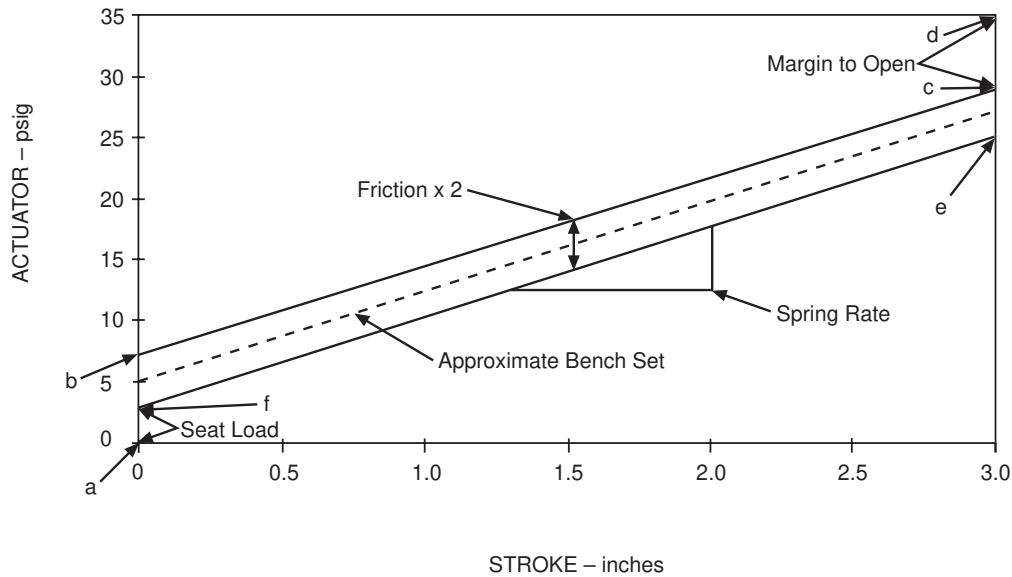

Figure 6-4
Mechanical Properties of a Valve

NOTE: The parameters bench set, spring rate, and spring linearity are only relative to spring-assisted valves.

When the valve is stroked from fully closed to fully open and back to fully closed, the plot of valve position versus actuator pressure might look like Figure 6-4. The valve starts from a fully closed position (a). Actuator pressure increases, the seat load (provided by the spring) and valve friction are overcome before the valve begins to move (b). The pressure continues to increase and the stem then moves in the opening direction in a linear fashion, as the spring is compressed, until the valve contacts the stop or back seat (c). Additional loading goes into the stop until the maximum actuator pressure is reached (d), Margin to Open.

On the return stroke, the actuator pressure starts decreasing until the spring overcomes the actuator pressure and valve friction and the valve starts moving in the closed

direction (e). The pressure continues to decrease, and the valve continues to move until it is fully closed again (f). As pressure continues to bleed off, the potential energy in the spring is transferred to seat loading (a).

From this plot, the following information can be calculated:

Approximate Bench Set: There is an in-depth discussion in Section 4.4.5.5 on bench set. In general, it is the pressure at which the actuator (in an uncoupled condition) starts to move and the pressure at which it reaches the specified stroke or stop, that is, 3 psig to 15 psig. The accepted method of determining bench set is with the actuator on the bench, not attached to the valve body, without external forces or friction such as packing friction or fluid forces. Because most of the testing utilizing the Data Acquisition System will be done (and is recommended to be done) with the valve body attached to the actuator and with valve friction, the term used here is *approximate bench set*. The differences between approximate bench set and bench set are typically caused by:

- The setup of the valve where the spring might be compressed a little more before the stems are coupled together
- The weight of the valve plug assembly
- Abnormalities within the valve stroke, that is, stem alignment, stem wear, or bent stem
- Packing that might cause more friction in one stroke direction than the other

Although the absolute values might be different between the approximate bench set and the bench set, the range should be the same. For example, the bench set might be 3 psig to 15 psig (a range of 12 psig), and the approximate bench set might be 4.5 psig to 16.5 psig (still a range of 12 psig).

The method of calculating the approximate bench set is to average the opening actuator pressure with the closing actuator pressure at the start of the stroke and the end of the stroke.

For example, to calculate the approximate bench set, using the information shown in Figure 6-4:

The average of the pressures at start of the stroke (b) and (f)

$$(7 \text{ psig} + 3 \text{ psig}) / 2 = 5 \text{ psig}$$

The average of the pressures at end of the stroke (c) and (e)

$$(29 \text{ psig} + 25 \text{ psig}) / 2 = 27 \text{ psig}$$

Approximate bench set: 5 psig to 27 psig

$$\text{The range is: } 27 \text{ psig} - 5 \text{ psig} = 22 \text{ psig}$$

Seat Load: The valve travel curve shows the valve plug contact with the seat (f) on the closing stroke. Any additional force applied (by the potential in the spring on an air-to-open valve or by actuator pressure on an air-to-close valve) results in seat load. From

Figure 6-4, the pressure decreases after the plug contacts the seat at 3 psig and continues to bleed off to 0.0 psig or a differential pressure of 3 psid. For a 9.5-inch effective diameter actuator, this calculates to a seat load of 212.7 pounds of force.

$$\text{Effective actuator area} = (\text{effective diameter} \div 2)^2 \pi$$

$$\text{Effective actuator area} = [(9.5 \text{ in} \div 2)^2 * (3.1416)] = 70.9 \text{ square inches}$$

$$\text{Differential pressure} = \Delta P = \text{pressure at valve closing} - \text{pressure at final bleed off}$$

$$\text{Seat load} = \text{effective actuator area} \times \Delta P$$

$$\text{Seat load} = [(70.9 \text{ in}^2) * (3 \text{ psid})] = 212.7 \text{ lbf}$$

It is important to realize that even though the valve stops moving, this does not mean that the valve plug has contacted the seat. The valve assembly could have contacted a stop in the actuator rather than the plug contacting the seat. There are a number of ways to determine if the valve plug is contacting the seat:

- Ensure that the valve-to-actuator-stem hookup procedure is performed correctly.
- In some cases, when the valve mechanical parts are not massive, some distortion of the yoke and stem can be observed in the plot of stem travel versus the actuator pressure. This appears to be additional travel after the plug has contacted the seat, see Figure 6-4A.

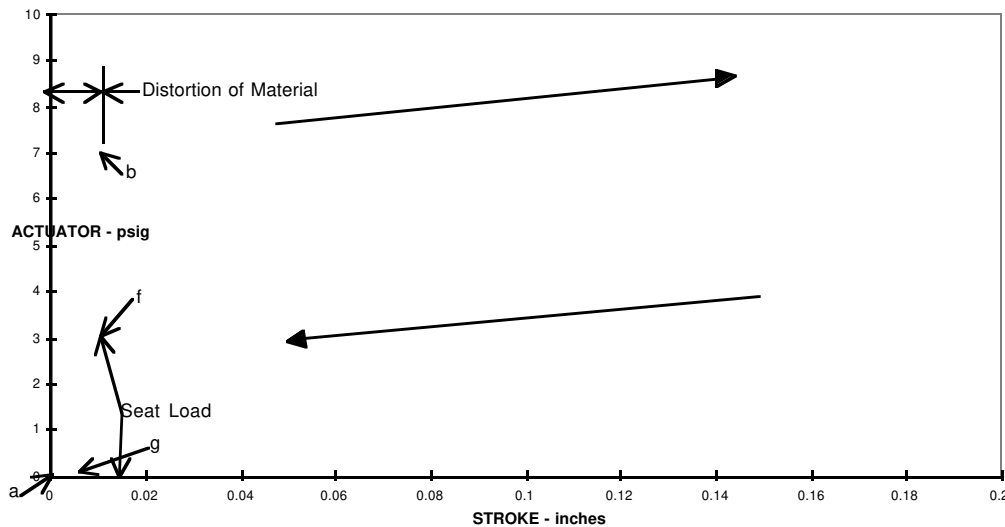

Figure 6-4A

Enlargement Section of Figure 6-2 (Shows Distortion Due to Seating Forces)

- The method that will provide the best assurance that the plug has contacted the seat is to strain gauge either the stem or the yoke, using some of the tools that are commonly available in the industry. The output from these strain gauges can be input into some of the Data Acquisition Systems, thereby recording this information. This equipment can also be used to distinguish an actuator problem from a valve body problem.

Margin to Open: The margin to open is the difference between the maximum air pressure available to the actuator and the pressure at which the valve reaches the full open position. In Figure 6-4, the margin to open would be the difference between (c) and (d) or 6 psig. It is also important to realize that the margin to open, with no pressure or flow on the valve internals under static conditions, is different than with system pressure.

Spring Rate: This is the slope of the actuator pressure versus stroke curve times the actuator effective area. For example, in Figure 6-4, the spring rate is 520 lbf/in and is calculated from the curve.

$$\text{Spring rate} = \text{effective actuator area} \times \text{bench set range} / \text{stroke}$$

$$\text{Effective actuator area} = 70.9 \text{ square inches}$$

$$\text{Bench set range} = (27 \text{ psig} - 5 \text{ psig}) = 22 \text{ psig}$$

$$\text{Stroke} = 3.0 \text{ inches}$$

$$\text{Spring rate} = [(70.9 \text{ in}^2) \times 22 \text{ psig} / 3.0 \text{ in}] = 520 \text{ lbf/in}$$

Valve Friction: The total valve friction is one-half the difference of the two operating curves at a constant stroke times the actuator effective area. Some of the Data Acquisition Systems can calculate minimum friction, maximum friction, and average friction by scanning the curve over the full stroke of the valve. While packing friction is typically the major friction involved, care must be exercised to ensure that the data are not misinterpreted. Other friction sources must always be considered, such as actuator seals, plug seals, or guiding surfaces drag.

The valve friction, in the example Figure 6-4, at the mid-stroke position is:

The opening stroke pressure at 1.5 inches is 18 psig.

The closing stroke pressure at 1.5 inches is 14 psig.

$$\text{Friction at 1.5 inches: } (18 \text{ psig} - 14 \text{ psig}) / 2 \times (70.9 \text{ in}^2) = 141.8 \text{ lbf}$$

Valve Stroke: The valve stroke can be directly determined from Figure 6-4 or from the data as being 3.0 inches.

6.4.2.2 Calibration of the Controlling Components

When the input and output parameters are recorded for each of the controlling components (I/P or E/P, positioner, volume booster), then the characteristics of that component can be determined and analyzed.

NOTE: It is very important to recognize the correct input and output parameters for a specific component.

The input is the control signal and the output is whatever element the component is controlling. For example; the input to an I/P is the milliampere control signal and the output is the pressure signal going to the next component. The positioner may have a pneumatic, voltage, or milliampere input control signal, but the output of the positioner is the position of the valve, it is **not** the actuator pressure. The actuator pressure is the medium or the force that the positioner uses to control the valve's position.

There are two common controlling components that are related to control valves. They are the I/P (or E/P) and the positioner. Each of these components has similar adjustments and characteristics. Each of them has a zero and a span adjustment, and each has inherent characteristics (typically supplied by the OEM on a specification sheet) that define whether the component is doing its job properly for the particular application. Some of these inherent characteristics are:

- Dead band
- Hysteresis
- Linearity

The definition of these terms is presented in *Method of Evaluating the Performance of Positioners with Analog Input Signals and Pneumatic Output*, published by the Instrument Society of America.

By having the AOV Data Acquisition System measuring the input and output of a component, the following information can be evaluated:

- The zero
- The span
- Dynamic hysteresis plus dead band, also dubbed dynamic error
- Linearity

The word *dynamic* in the terms dynamic hysteresis plus dead band or dynamic error is used because the data is recorded under dynamic conditions. The Data Acquisition System is continually changing the input signal over time and does not allow the valve to stabilize at any given point. The ISA Standard S75.13, which defines the method for obtaining the parameter hysteresis plus dead band, requires that "...the input shall be held steady until the device under test becomes stabilized at its apparent final value." If the AOV Data Acquisition System is controlling the valve properly (longer ramp), the dynamic hysteresis plus dead band recorded should be at least equal to, but can be slightly greater than, that recorded using the ISA method.

Therefore, in some cases, this information can be compared to the manufacturer's specification value, but in most cases, because the data is collected under dynamic conditions, it is prudent to compare the results to a known, acceptable baseline test that was conducted under similar conditions.

The following are examples of plots and methods used to obtain or calculate some of this information.

6.4.2.2.1 Transducers

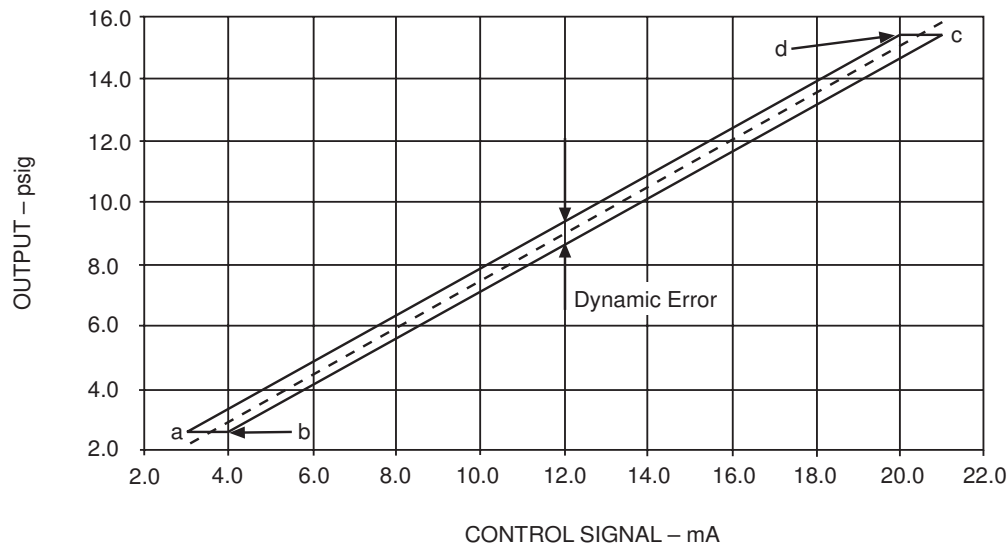

Figure 6-5
Typical Calibration of I/P Transducer

NOTE: The dynamic hysteresis plus dead band in the above curve is greatly exaggerated to show what is happening. In most cases a transducer has a dynamic hysteresis plus dead band of less than 1%.

During a normal ramp test, the input signal starts out at a minimum signal (a). As the control signal increases, the output, because of inherent factors, does not start to increase until point (b). From (b) to (c), the output follows the input in a linear fashion. As the input signal starts to decrease (c), the output again lags until point (d) and follows the input signal returning to point (a).

Key information that is measured or calculated is described below:

Zero: The minimum calibration signal (zero) is obtained by averaging the output signals in the up and down directions at a constant input signal. In the above example, the average between the up and down lines as these cross 4 mA is 3 psig.

The readings at 4 mA are:

Increasing — 2.64 psig

Decreasing — 3.36 psig

The average reading is: $(3.36 \text{ psig} + 2.64 \text{ psig}) / 2 = 3.0 \text{ psig} = \text{Zero}$

Span: The span is the range of the output of the instrument between the minimum and the maximum input signal. For a 3 to 15 psig output transducer, the span (or range)

should be 12 psig, and if the zero is set at 3 psig, the maximum value should be 15 psig. So to determine the span, the average values, at the 20 mA and 4 mA input values, are subtracted from each other. In this case, the value would be 15 minus 3 or 12 psig. It is common to refer to the zero and span as being 3 psig and 15 psig, respectively, ignoring the fact that they should be subtracted to get the span.

The readings at 20 mA are:

Increasing — 14.64 psig

Decreasing — 15.36 psig

The average reading is: $(14.64 \text{ psig} + 15.36 \text{ psig}) / 2 = 15.0 \text{ psig}$

Therefore, the span = $(15.0 \text{ psig} - 3.0 \text{ psig}) = 12 \text{ psig}$

Hysteresis Plus Dead Band: This information is obtained anywhere along the curve at a constant input control signal. The difference between the output signal while increasing and the output signal while decreasing at a given input is normally divided by the complete range of the output to obtain a value that is in percent. For example;

At 12 mA, input control signal

Increasing signal — 8.64 psig

Decreasing signal — 9.36 psig

$$(9.36 \text{ psig} - 8.64 \text{ psig}) = 0.72 \text{ psig}$$

The span or range is 12.0 psig, therefore

$$0.72 \text{ psig} / 12.0 \text{ psig} * 100 \text{ (to obtain percent)} = 6.0\% \text{ dynamic error}$$

Calculating a number of samples along the length of the curve provides minimum, maximum, and average values for dynamic hysteresis plus dead band.

Linearity: Linearity is used to determine how well an instrument's output follows the input control signal. By setting the zero and span adjustments, it is already known that the instrument is calibrated at these points; what is not known is whether the output follows the input between these points. The linearity of an instrument has, in the past, been evaluated using the three- or five-point calibration check, so this is not really something new.

Using the AOV Data Acquisition System there are a number of ways to evaluate the linearity of the instrument:

- **Three- or Five-Point Calibration Method** — The evaluator would go in at the three or five points and obtain the average output values (up and down) at those points and determine if they fall within the plant's predetermined margins.
- **Independent Straight Line Method** — A best fit straight line is calculated through the data, and the average of the data obtained from the Data Acquisition System is then compared to the value of the best fit straight line at a constant input. The maximum error is then compared to an acceptance criterion to determine whether the instrument is acceptable.

- **Terminal-Based Straight Line Method** — This is the same method as the independent straight line method, except that the points obtained for the zero and the span are used as the end points of the straight line.

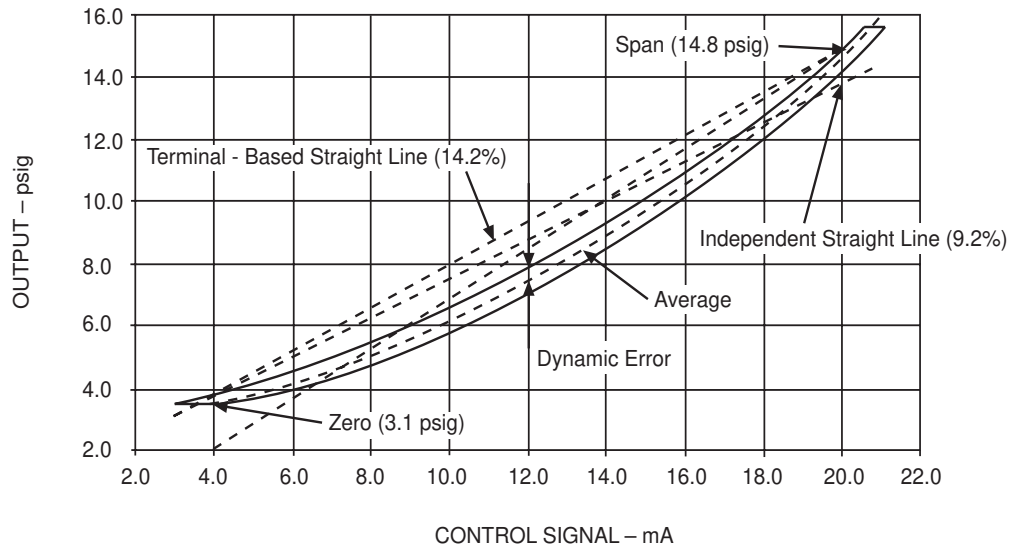

Figure 6-5A
I/P Calibration with Linearity Considerations

Visual Method: Although this method is open to interpretation and there are no numeric results entered into the calibration sheet, this method works well as a quick evaluation. The technician simply looks at the plot of input versus the output and compares it to a straight line. In most cases, a bad instrument is obviously bad and can be rejected based on a visual inspection.

6.4.2.2.2 Positioners

As in the case of the I/P, the positioner can be looked at as a separate entity. The input signal to the positioner is either an electronic or pneumatic signal, initiated from either a controller or I/P, and the output is the valve's position. Figure 6-6 shows the calibration of a typical positioner.

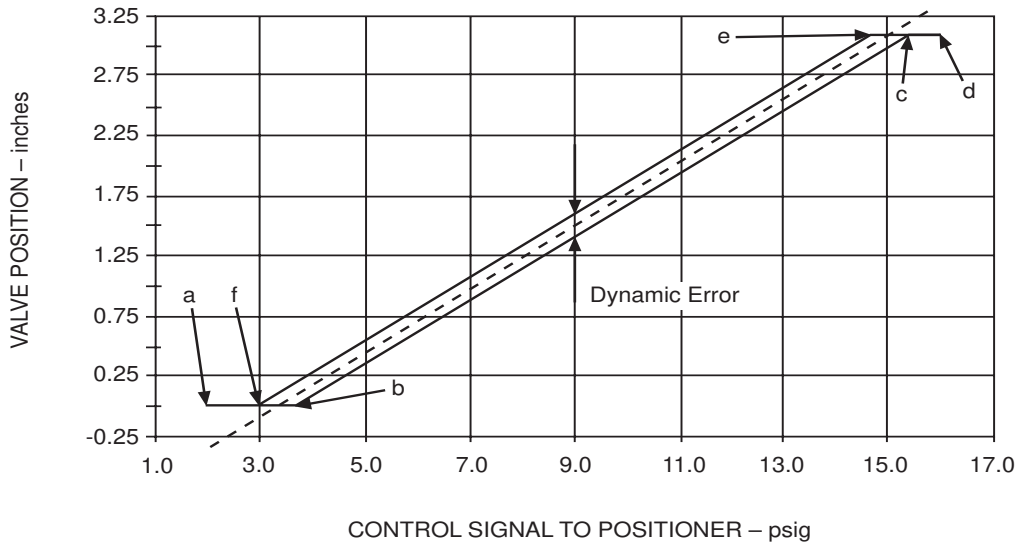

Figure 6-6
Calibration of Valve Positioner

The typical ramp starts out at a minimum signal (a) and increases to the point when the valve starts to move (b). The output travel follows the input signal in a linear fashion until the valve plug or actuator contacts the open stop (c). From this point, the signal continues to increase without any change in the valve's position until point (d) is reached. When the input signal starts to decrease, it continues until it reaches point (e), at which point the valve starts to close. The valve follows the signal down until the valve plug contacts the seat (f). Again, the signal continues to decrease until point (a) is reached, without any valve movement.

Most of the same terms and methods of calculation are used; that is, zero, span, dynamic Hysteresis plus dead band, and linearity are all used for the positioner just as they were for the I/P. But because of the presence of a mechanical feedback loop and other mechanical parts, errors in both magnitude and shape of the hysteresis and linearity are generally greater. Again, the numbers obtained from the data acquisition testing might have to be compared to an acceptable baseline rather than to manufacturer's specifications. Some additional items that might be of interest are:

What is the value at 15 psig (full open signal)? = 3.0 inches

(This was obtained on the opening stroke when the valve position crossed the 15 psig input signal)

What is the full open position? = 3.1 inches

(The maximum position that the valve reaches (c), might be greater than the position that is reached at the 15 psig signal)

What is the input signal when the valve reaches the closed position? = 3.0 psig

(The signal just as the valve reaches its closed position on the down stroke (f))

What is the value at 3 psig (full closed signal)? = 0.0 inches

(On the down stroke, what is the valve is position as it crosses the 3 psig input signal)

The method of calibrating a positioner is important when a control valve **must** do a specific function within the system. The following are some examples:

- The highest accuracy is obtained from a positioner when it uses its full design span over the full flow span of the valve. In this case, the positioner's zero should be set at the exact opening of the valve stroke and the span set at the full flow position of the valve.
- In some cases, a valve **must** be closed when the control signal reads its minimum value; for example, given a 3 psig signal, the full seat load must be developed to provide isolation. In this case, the valve should be set to close at some value above the zero point (consider the dynamic error).
- Valves that must open or close quickly to meet some time requirement would be better set up to have a minimum seat load or back seat load, or no seat load or back seat load. These valves should be set up so that the valve plug is just off its seat, or back seat, at the zero or span signal so that the valve does not develop its seating, or back seating, load.

As can be seen, there are many things that should be considered before the positioner on a control valve is set up.

6.4.2.2.3 Overall Calibration

Another calibration plot that is more informative and practical in the field, when the valve has both an I/P (or an E/P) and a positioner, is the overall valve calibration. This plot would look the same as Figure 6-4 except that it combines both an I/P (or E/P) and a pneumatic positioner and looks at them both as a "black box." This plot would provide an overall picture of how the transducer and positioner function together to provide the output, which is the valve's position.

When calibrating these two instruments, it is recommended to begin with the I/P (or E/P), because it is both easier to calibrate and more accurate. After the transducer is calibrated, it is recommended that, while using the same electronic control signal to the transducer, the positioner be calibrated.

Using these methods to evaluate a valve, most common valve problems can be quickly recognized by the trained valve technician. When more complex problems are suspected, further analysis must be performed to determine the underlying problem.

The normal test time for a valve is less than 30 minutes—15 minutes to set up, 5 minutes to do two or three test strokes, and 10 minutes to disconnect. This does not include the time to obtain permission, write the procedures, or get the equipment to the valve. A

quick review of the data analysis can be accomplished at the valve. A more detailed review of the collected data can be performed at a later time.

The installation of quick disconnects at the valve location can provide additional savings in labor. If this is to be accomplished, a generic procedure can be submitted to engineering for approval, possibly allowing installation in conjunction with normal valve repairs or maintenance. An example of a generic procedure to install quick disconnects and where to locate them is provided in Appendix C.

It should be noted that quick disconnects for safety-related valves might have to be addressed independently.

6.5 PLANT SYSTEM APPLICATION

There are many other possible applications where the AOV Data Acquisition Systems can be used.

In most cases, when there is a problem with a system, The Valve gets the attention, and in at least 90% of the cases, it deserves the attention. But in the other 10%, how do you prove or disprove the valve's involvement in the problem? By monitoring both the control signal going to the valve, and the valve's stroke while the problem is occurring, in most cases the problem can easily be determined as either occurring upstream of the valve or being caused by the valve. With quick disconnects on the pneumatic instrument control signal, this evaluation can be accomplished easily and safely. Planning is required to monitor an electronic control signal without interrupting it.

The opportunities to collect data and diagnose plant system problems are endless, yet they should be addressed only by someone who is familiar with the Data Acquisition System and the plant operation or problem that is causing the concern.

In other possible applications, the diagnostic system can be used to loop check a system, for example, one in which a level transmitter provides a signal to a controller to maintain a level within a specified range. The level controller sends a signal to the positioner that controls the valve that controls the input or output of the system to maintain the level. In this case, the Data Acquisition System could be used to send the initial level signal to the controller while monitoring the valve's response to that signal.

6.6 OUTAGE PLANNING

AOV Data Acquisition Systems can non-intrusively and relatively quickly determine the mechanical and control condition of the valve and actuator. By testing key valves at the beginning of an outage, maintenance efforts can be focused on the valves with the critical problems, while "good" valves can be left for a future outage or as time allows.

6.7 PREDICTIVE MAINTENANCE

Proper use of an AOV Data Acquisition System can provide assessment of the control component condition and indication of elastomer degradation. This information can be used to determine the current equipment condition and, when compared with historical records, predict its remaining useful life. Discovering substandard valve operation or conditions before failure can save substantial maintenance time and expense.

6.8 DATA ACQUISITION SYSTEM BENEFITS

6.8.1 *Reduced Maintenance Expense*

- Testing can help prioritize repairs, reducing workload.
- Testing can isolate the components on a valve that really need repair, rather than repairing the whole valve.
- Testing done in advance of an outage can help improve outage planning and reduce emergency parts stock.
- Testing can help eliminate or pinpoint the control valve as a potential cause of a loop problem signaled by operations.
- Long term analysis and documentation can help determine root causes and point to permanent solutions. Problems will decrease over time.

6.8.2 *Reduced Downtime*

- Regular use will improve setup and operation, so that on-line problems should decrease.
- Trending permits the use of preventive and predictive maintenance techniques, further reducing on-line problems.

6.8.3 *Improved Process Efficiency*

- Correct seat load and packing friction reduces the potential for leaks.
- Verifying correct valve operation facilitates loop tuning.
- Analysis of valve response permits physical modifications to the valve and air supply to better match the response to the process requirements.
- Elimination of sticking and jumping permits better tracking of the input signal.

6.8.4 *Improved Safety*

- Fewer leaks mean lower exposure.
- Better control means safer shutdowns.

6.8.5 Improved Training

Using the system in conjunction with a training program permits easy visualization of such things as bench set and packing friction and helps improve overall maintenance performance.

6.8.6 General Benefits

When used as a calibration device, the proper setup and calibration are ensured. A printout of this information provides documentation of this setup.

7

DIAPHRAGMS

7.1 INTRODUCTION AND BACKGROUND

One of the most critical and more sensitive components of an air-operated valve (AOV) is the diaphragm. This provides the seal that allows a successful actuation by overcoming the spring pressure that is used to return the valve to its “safe” position. Since the diaphragms are pressurized either during service or when the valve is cycled, flaws, surface damage, or internal defects within the diaphragm can lead to a significant rupture and/or leakage without warning. A number of diaphragm-related failures have been reported, and these events have often led to costly shut-downs.

This chapter has been designed to provide guidance for selecting, installing, maintaining, and assessing the initial condition of AOV diaphragms. Other soft parts in the valve are addressed because many of the issues are similar for O-rings, gaskets, and stem seals, for example. A review of common causes of failure and basic failure analysis techniques has also been provided.

AOV diaphragms feature a raised center section with a flat flange edge. Figure 7-1 provides a basis for uniform terminology when different areas are referred to in this document. The overall diameter of typical diaphragms ranges from 6 inches to more than 18 inches. The flange edge is commonly 1-inch wide and the center hole is approximately 0.75-inch diameter. In practice, the perimeter seal is established by compression of the flanges using a bolted housing. The center is sealed by use of a compression seal against flat support plates on both faces of the diaphragm.

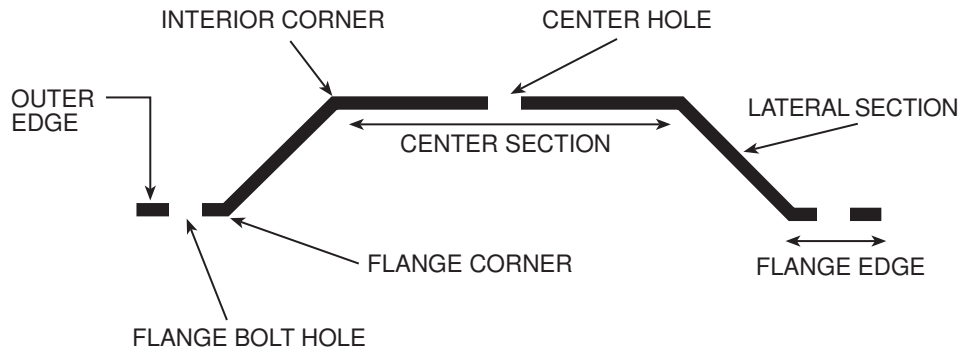

Figure 7-1

Cross-Section of Representative AOV Diaphragm, with Component Areas Identified
(Not Prepared to Scale)

It should be noted for nuclear plant applications that safety-related valves are environmentally qualified (EQ), but the diaphragm is a non-EQ part. The diaphragms have instead been commercially qualified; so no EQ profiles have been generated. Therefore, this chapter will not refer to any EQ data files or information but will rely on information from direct analysis of diaphragms from failure analysis studies, evaluation of non-aged diaphragms, technical literature, manufacturer's data from polymer suppliers, and fundamental aspects of polymer science.

7.2 DIAPHRAGM SELECTION

Few vendors supply diaphragms specifically for AOV applications, but the designs follow the same basic concepts. Although the choices are limited, this section provides background engineering and technical information regarding the best available materials options for particular environments. Typical diaphragm constructions involve a molded rubber portion reinforced with a woven fabric. The fibers are either attached to the rubber on one side only (less typical) or are molded between two layers of rubber (majority). The latter is the default case in this document.

There are various manufacturing steps that are critical to the successful production of an AOV diaphragm. The rubber compound must be developed with suitable materials and a good mixing process, the rubber and fibers must be molded into a uniform and defect-free composite, and the rubber must be crosslinked (cured) to ensure that the diaphragm will retain its as-molded shape and will be durable enough for its service environment over the long term. These processes are briefly described in this section to provide a better understanding of the importance of these issues as they relate to AOV diaphragm performance.

7.2.1 Compounding

Many of the trade names for polymers, such as Buna-N™ and Neoprene™, along with the silicone rubber group, refer to families of polymer products rather than a specific

item. These names apply to the base resin in a polymer compound that can be tailor made for specific applications. Neoprene, for example, is a trademark of DuPont and refers to a family of chlorinated polyethylene base resins that can be compounded for a variety of applications. Engine mounts, foam mattresses, conveyor belts, adhesive coatings, and flexible hoses are among the applications suggested in DuPont's marketing literature for this material. The base resin provides a continuous phase in which the other ingredients are mixed and gives the basic characteristics of the elastomer such as tensile strength, flexibility, and chemical properties. The base resin of choice is mixed with other materials to improve its processing characteristics and final engineering properties. This mixture is known as a compound, but it is often generically referred to somewhat erroneously by the name of the base resin.

Compounds frequently contain mineral reinforcements, flame retardants, antioxidants, processing aids, crosslinking initiators, moisture inhibitors, and others depending on the final requirements for the part. Differences in formulation can significantly affect the performance and aging characteristics of the final compound. Unfortunately, there is no standard nomenclature for advertising these differences, unlike metals, which use a standardized numbering system to distinguish different alloys and heat treatments. These differences are seldom labeled and lot-to-lot variations from the same manufacturer are not uncommon.

No methods are readily available to distinguish these differences when new diaphragms arrive from the manufacturer, short of simple screening tests for overt variations and detailed chemical analyses for more subtle differences. It is recommended that all parts be inspected to ensure that certain minimum requirements are met to reduce the potential for future inservice problems. This is addressed in Section 7.5.

It is also important to avoid using manufacturer's data sheets or other generic data to define the properties of a polymer that has been compounded because this can be misleading. Figure 7-2 shows two typical Buna-N formulations. The base resin for both compounds in Figure 7-2 is identical, but the performance characteristics are quite different due to the filler and additive packages. When specified on the basis of nominal Buna-N rubber and a target durometer hardness alone, the compounds would be "identical."

<u>FORMULATION 1</u>	<u>FORMULATION 2</u>
100 parts elastometer resin (Buna 345)	100 parts elastometer resin (Buna 345)
60 parts magnesium silicate (talc)	30 parts kaolin alumino-silicate
20 parts silica	5 parts zinc oxide
6.5 parts redolox 145 peroxide	2 parts lead monoxide
1 part stearic acid	5 parts dicumyl peroxide
	2 parts antioxidant
<u>PROPERTIES</u>	<u>PROPERTIES</u>
TENSILE: 2500 PSI	TENSILE: 3500 PSI
ELONGATION: 240%	ELONGATION: 400%
DUROMETER: 70	DUROMETER: 70
CLASSIFICATION: BUNA	CLASSIFICATION: BUNA
<u>PERFORMANCE</u>	<u>PERFORMANCE</u>
EXCELLENT RELEASE	GOOD RELEASE
HIGH MOISTURE SENSITIVITY	HIGH MOISTURE RESISTANCE
LOW OIL STABILITY	GOOD OIL STABILITY
HIGH SURFACE TACK AFTER HEATING	LOW SURFACE TACK AFTER HEATING
POOR FLEXURAL RESISTANCE	HIGH FLEXURAL RESISTANCE
POOR THERMAL STABILITY	HIGH THERMAL STABILITY

Figure 7-2
Comparison of Buna-N Formulations (Concentrations in PHR Resin)

The quantity and type of additives in compounds vary by application. One organic material that is always present in some form is an antioxidant. Antioxidants are typically hindered phenolic compounds that protect the base resin from thermal exposure (oxidation) during processing. This additive also provides limited protection from thermal degradation inservice, although in most cases the antioxidant is consumed during the cure cycle and is effective only at very high temperatures. It is used in very small quantities, such as 0.5% or less of the total weight of the compound, but it is essential to protect the resin from scorching, oxidation, and other thermally related processing damage. The process of curing (crosslinking) a rubber requires that it be heated to 175°C, which is well above the level required for oxidation of an unprotected polymer.

Rubber compounds are formulated using the polymer as the basis for the relative weights of the other components. If, for example, a batch of compound contains 5 lbs. of rubber resin and 5 lbs. of clay, the concentration of clay is 100 “phr” or 100 parts-per-hundred resin, on a weight basis. This is a standard practice that dates back to the earliest days of rubber compounding.

Plasticizers are ring-structured compounds, such as dioctyl phthalate, that improve the processing characteristics of the compound and promote flexibility. This material is added to compounds in small quantities for applications similar to AOV diaphragms, but can be a major additive if extreme flexibility is required for applications such as flexible tubing. It should be cautioned that plasticizers are often not fully stable in the compound and sometimes migrate at elevated temperatures. They are also quite polar by design, which is part of what makes them successful in their intended compound, but allows them to cause significant damage to rubbers and plastics if they migrate to other components. Plasticizer exposure can cause extreme swelling or induce unwanted adhesion in a wide range of rubbery materials. Plasticizers and other additives, such as stearic acid, also offer internal lubrication to the compound during processing and to the final part inservice.

Stabilizers are sometimes added to improve the performance of the compound. Zinc oxide and lead tetraoxide are common thermal stabilizers. Lead compounds have the added advantage of reducing swelling when the rubber is exposed to liquid water or water vapor for prolonged periods. Carbon black and benzene ring compounds are used as ultraviolet (UV) stabilizers to protect parts that will be exposed to sunlight and/or other UV sources. Carbon black also adds to the mechanical strength of rubber compounds, as evidenced in its huge volume application for automotive tires. Insulator materials often contain voltage stabilizers such as metal complexes, non-ionic surfactants, and polar compounds.

Although this it is not a critical concern for AOV diaphragms, many polymeric components in power plants must meet certain flammability requirements. Flame retardants are often added to these compounds to improve their flame-suppression characteristics and to reduce the toxicity of the smoke in some cases. Some of these additives work synergistically with other materials, such as an antimony trioxide/halogen combination. Others, such as alumina trihydrate, hydrated phosphates, or zinc borate, work alone. These are added in varying amounts, depending on the compound and flammability requirements.

Mineral reinforcements, such as kaolin, silica, alumina, and talc, are added to the compound to reduce the unit cost and improve mechanical properties. These are often referred to as “filler” materials. The fillers are traditionally added in quantities of 20 to 50 weight percent of the total compound. If properly selected, these materials will enhance the mechanical properties such as creep resistance, tensile strength, hardness, resistance to permanent set, and compression strength. The filler materials vary by moisture content, particle morphology, particle size, purity, and incorporation of a chemical coupling agent. Their morphology can significantly affect a component with a

critical sealing function because a large particle with sharp edges tends to pull from the matrix and prevents a continuous sealing surface.

Other processing aids such as waxes, oils, and mold release agents are often used in small concentrations, depending on the application. Due to solubility limitations, these materials have a propensity to migrate to the surface of the component during service and form a chalky or waxy film. This film does not present any immediate problems in an AOV diaphragm application and can often serve as an indication of thermal aging. These materials can also act as a source of internal lubrication for the finished part. In their absence, an increase in hardness would be expected. This indicates one reason why a change in hardness cannot be interpreted as direct evidence of oxidative aging.

The raw materials selected for a specific compound can be mixed in a number of different machines, depending on the desired characteristics and materials to be blended. A common example is an in-line kneader. This machine uses different hoppers that feed into a heated single-screw mixing barrel. This is typically interfaced with a second extruder that provides the compound in pellet or strip form. The materials are fed in a specific order to promote the best mixing possible. The base resin, for example, would be in the first hopper. After the material has been thoroughly mixed in the screw extruder, it is fed through a screen pack to prevent the entrapment of debris or non-mixed materials. The compound is then run through a pelletizer to provide pellets for later applications or, in some cases, it is fed directly into a mold or other fitting to make a final part.

More commonly for rubber compounds, an internal mixer is used. This machine mixes rubber and its additives between two counter-rotating, intermeshing kneading screws. The machine is externally heated to melt the materials, then cooling is provided to prevent overheating due to high internal friction forces. With an internal mixer, all ingredients are added as a batch and this batch maintains its identity through the molding of the final product. Internal mixers are made by a number of companies. The technology is typically identified by the originator, Banbury, though other similar mixers are made by Farrell, Davis Standard, and others. Mixing technologies are illustrated in Figures 7-3 through 7-5.

Rubber compounds are typically run through a second mixing operation, known as calendaring or "milling." This step achieves thorough long-range mixing and homogenization of the compound by compressing it many times through a heated two-roll mill. This produces sheets of highly uniform compound, which is then ready for molding.

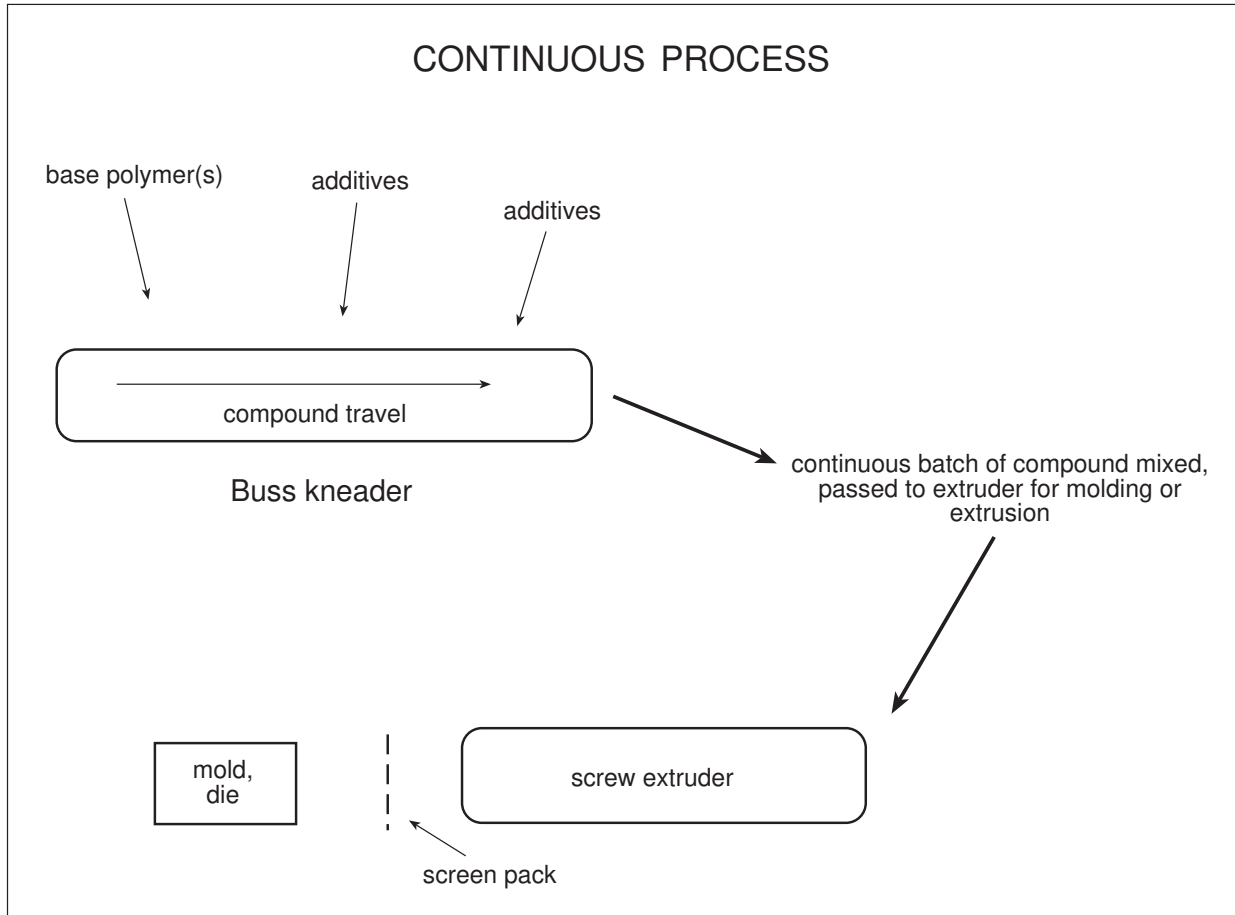

Figure 7-3
Block Diagram of In-Line Kneader Type Mixer for Preparing Elastomeric Compounds

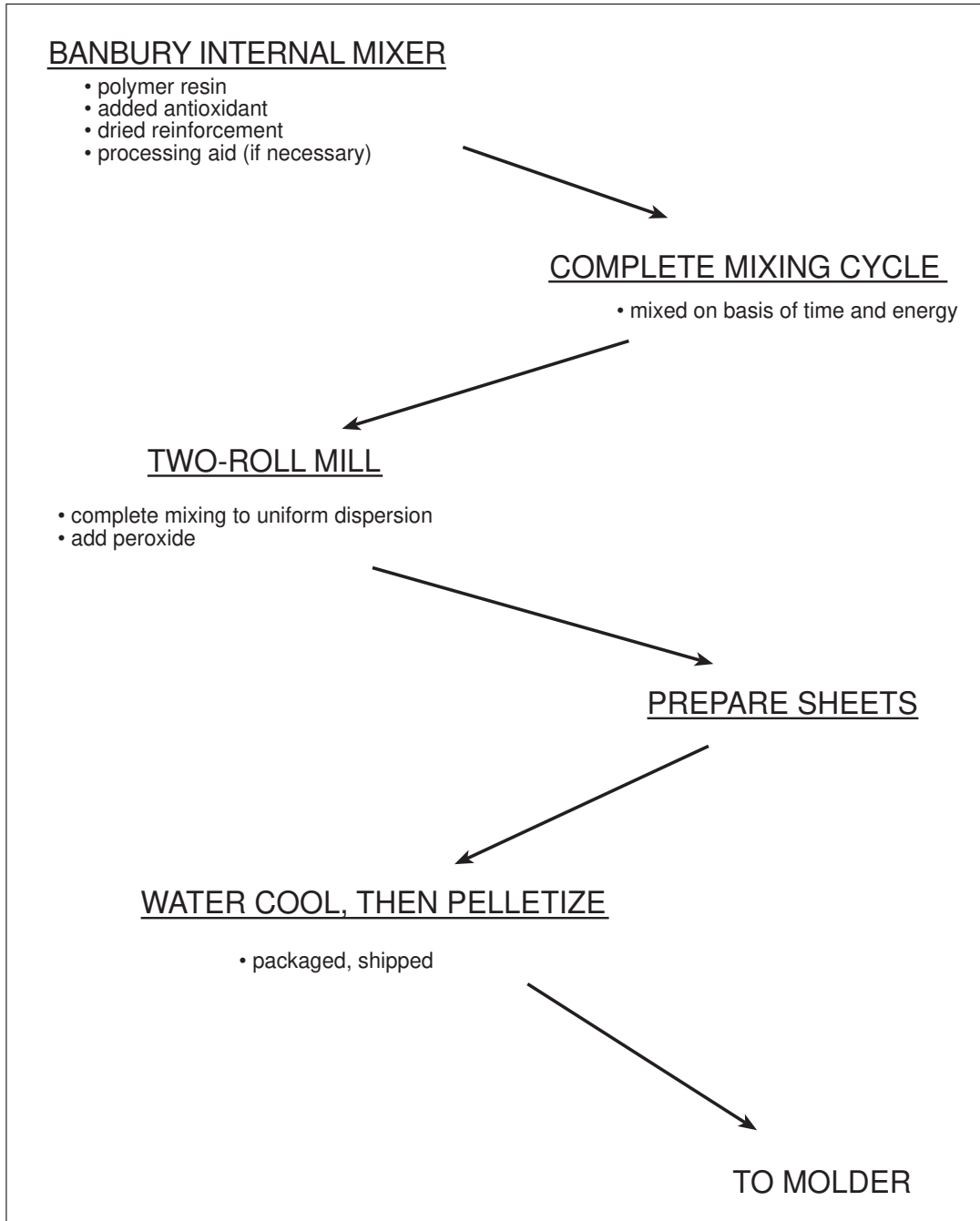

Figure 7-4
Diagram of Internal Mixer and Its Relationship to the Milling Process

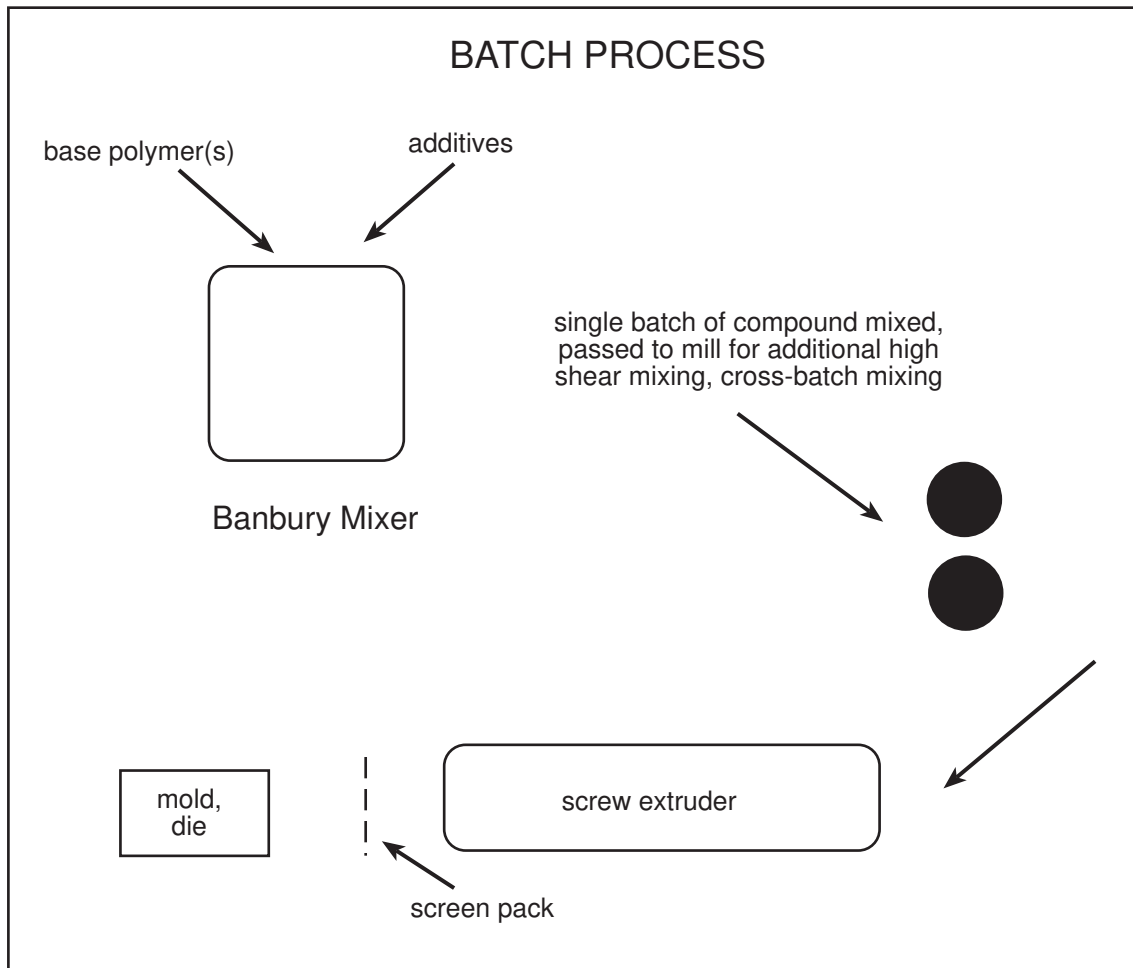

Figure 7-5
Illustration of Banbury-Type Internal Mixer

7.2.2 Molding

Diaphragms are typically manufactured through an open cavity molding process. The rubber is compounded and formed into plugs of a known weight. These plugs are then placed in a hot press to form large disks, which will become the outer layers of the diaphragm. The disks are placed on both sides of a piece of the reinforcing fabric. The three parts are hot pressed again to allow the rubber to bond and flow around the fibers, depending on the weave construction. In many cases, after the rubber is in place, the mold temperature is raised to approximately 175°C at which a crosslinking reaction of the rubber begins. Crosslinking takes place for approximately 15 minutes, and the diaphragm is cooled inside the mold for shape retention. Crosslinking is further addressed in Section 7.2.3. The molding process is illustrated in Figure 7-6.

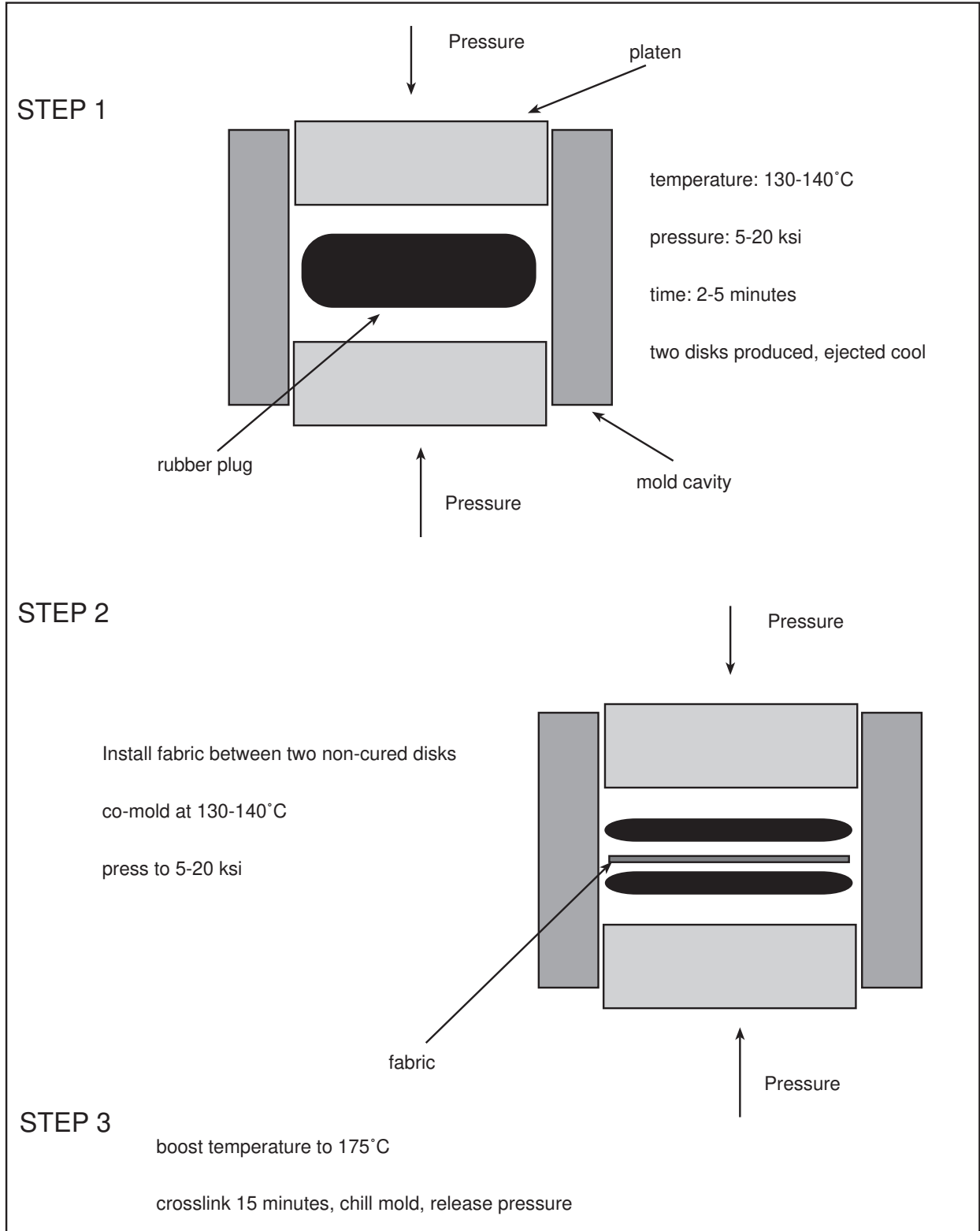

Figure 7-6
Molding of Fabric-Reinforced Components

Molding of other rubber parts, such as O-rings, gaskets, and seals, would be quite similar in the overall sense. In most cases, the starting form of the material consists of pellets or strips of raw compound. These are melted and injected under very high pressure into a mold. The mold temperature is sufficiently high that crosslinking proceeds.

7.2.3 Crosslinking

The crosslinking reaction is vital to the consistent performance, dimensional stability, solvent resistance, and compression set resistance of the rubber. Crosslinking limits polymer deformation by creating short, rigid links between the polymer chains, which prevents them from sliding past each other when a force is applied, as shown in Figure 7-7. This slippage is what allows the polymer to flow and elongate. Crosslinking also makes a polymer more resistant to chemical and thermal degradation. Crosslinked materials cannot be melted; hence, they are called *thermoset*. Rubber materials and plastics that can be re-melted and reformed are called *thermoplastic*.

There are several methods available for initiating a crosslinking reaction. Among the common choices are:

- Radiation activated with X-rays or electrons
- Thermally induced crosslinking with a peroxide or sulfur catalyst
- Water initiation with a reactive silanol

The most common method for AOV diaphragm rubber crosslinking is thermally-induced curing with a dicumyl peroxide or sulfur process. This method is preferable because it can be easily incorporated into the molding process and offers a fairly reasonable degree of control, because the degree of crosslinking is related to the amount of crosslinking agent in the rubber.

To complete the cure at the desired stage of rubber component manufacturing, the rubber compound is first prepared, and then the crosslinking agent is typically added to the compound in its final mixing stages on a two-roll mill. Care must be taken to keep the compound temperature below that required for crosslinking initiation. When molded into a final form, the component is heated to approximately 175°C to thermally decompose the crosslinking agent. When accomplished, this forms reactive chains known as free radicals. These then react with the polymer chains, forming the crosslinks.

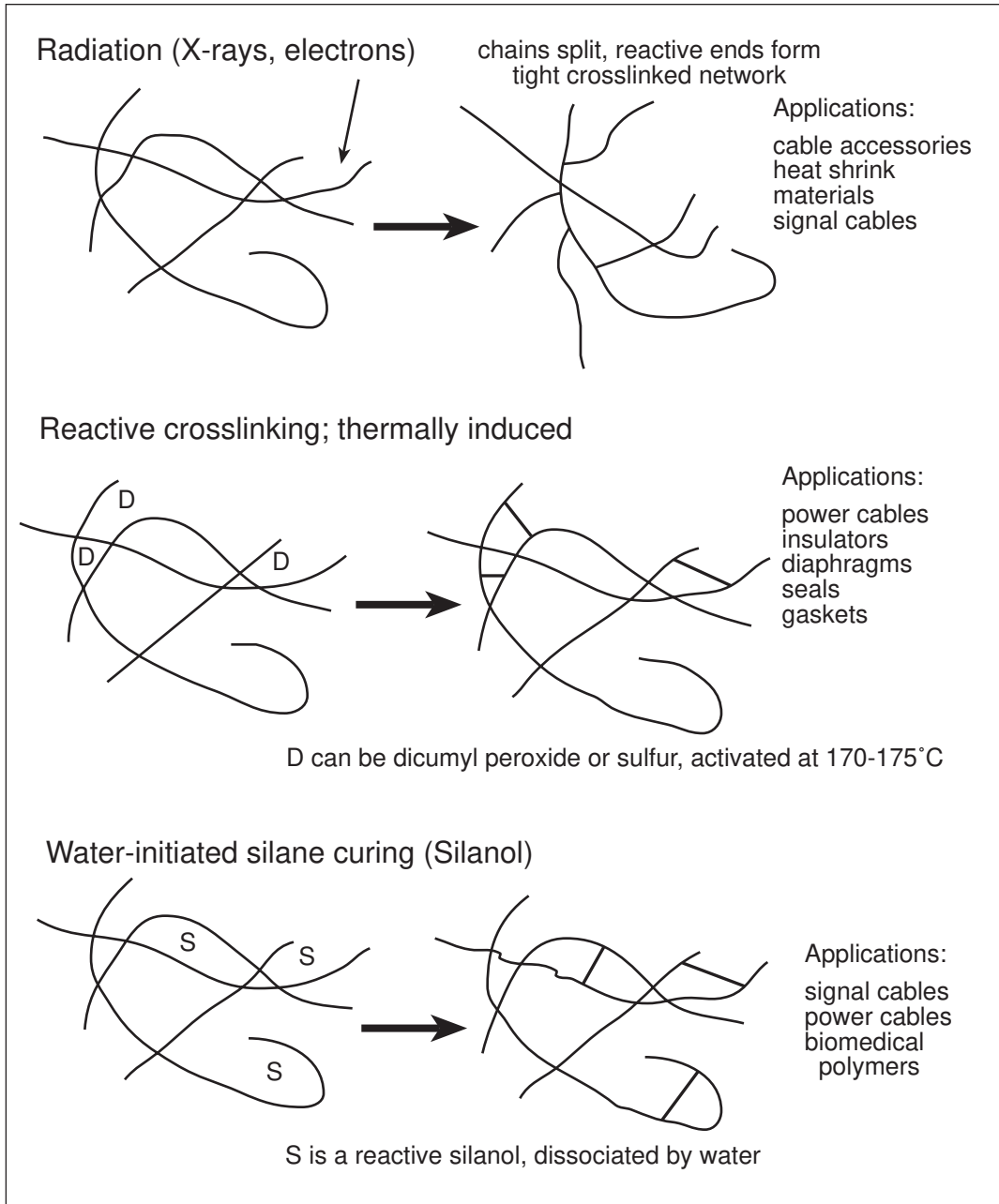

Figure 7-7
Illustration of Crosslinking Methods

7.2.4 Rubber Options

Neoprene, Buna-N rubber, silicone rubber, and ethylene-propylene rubber are the four most popular elastomers for the rubber component of AOV diaphragms. As discussed above, Neoprene is a DuPont trade name for chlorinated polyethylene. Silicone rubber refers to a methyl silicone rubber that is produced by Dow Chemical company, 3M, or DuPont. Buna-N rubber refers to a large variety of nitrogen-carbon-hydrogen polymers.

This material is made by a number of suppliers and is available in many grades. Ethylene-propylene rubber is a synthetic hydrocarbon rubber made by copolymerization of ethylene and propylene polymers. This material is typically supplied by DuPont under the Nordel trade name or by Exxon Corp. under the Vistalon name. Although they vary widely based on final formulation, the properties of these three elastomers are generally compared in Figure 7-8.

	NEOPRENE	VITON	SILICONE RUBBER	BUNA RUBBER
Tensile Strength	H	M	M	H
Elongation	H	L	M-H	H
Hardness	L-M	M-H	L-M	L-M
Thermal Stability	M	H	H	M-H
Chemical Resistance	M-H	H	H	M
Oil Resistance	L-M	H	H	L
Resistance to Perm. Set	H	L	H	H
Tear Resistance	H	H	L	H

Figure 7-8
Comparison of Elastomer Characteristics

7.2.5 Fiber Options

The fiber reinforcement is incorporated into the AOV diaphragm design to offer increased strength, creep resistance, and sealing performance while still maintaining the diaphragm's flexibility. The fibers are formed into a fabric with varying fiber diameters, fiber counts per bundle, and weave characteristics. Among the available options are Dacron™, nylon, rayon, cotton, and aramid fibers such as Kevlar or Nomex. Nylon and Dacron are the most popular for current AOV diaphragm applications.

Through analysis of AOV diaphragms recovered from the field or removed directly from plant warehouses, the fiber weaves have been evaluated. The reinforcing fabric basically consists of a criss-cross woven pattern of cords. Each cord is comprised of a bundle of parallel, continuous fibers.

Both Buna-N and Neoprene diaphragms typically contain nylon fibers while the Silicone diaphragms commonly use Dacron fibers. The Neoprene diaphragm fiber weave has been known to contain approximately 274 fibers per cord. The Buna-N diaphragm

weave often features approximately 68 fibers per cord. This difference is clearly shown in the scanning electron microscope (SEM) photomicrographs presented in Figures 7-9 and 7-10, which exhibit exposed sections of both weaves at the same magnification.

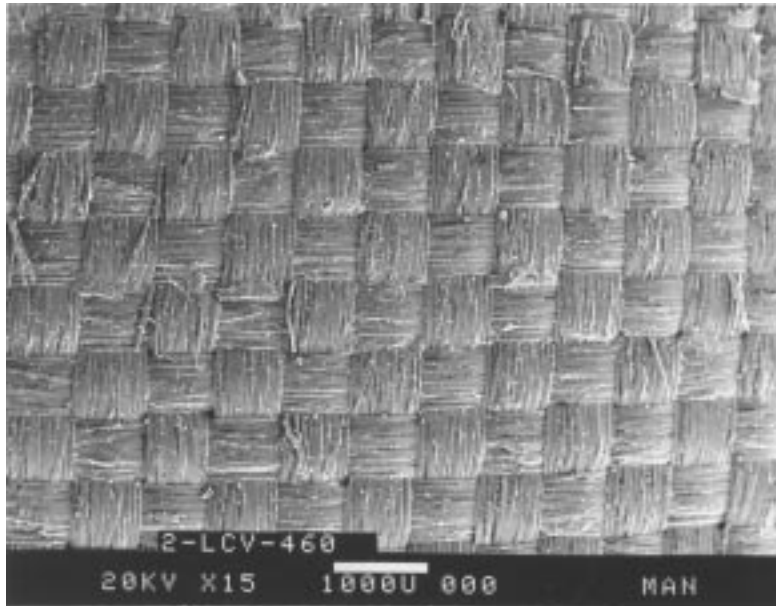

Figure 7-9
SEM Photomicrograph of Buna-N Diaphragm Fiber Weave, Magnification 15x

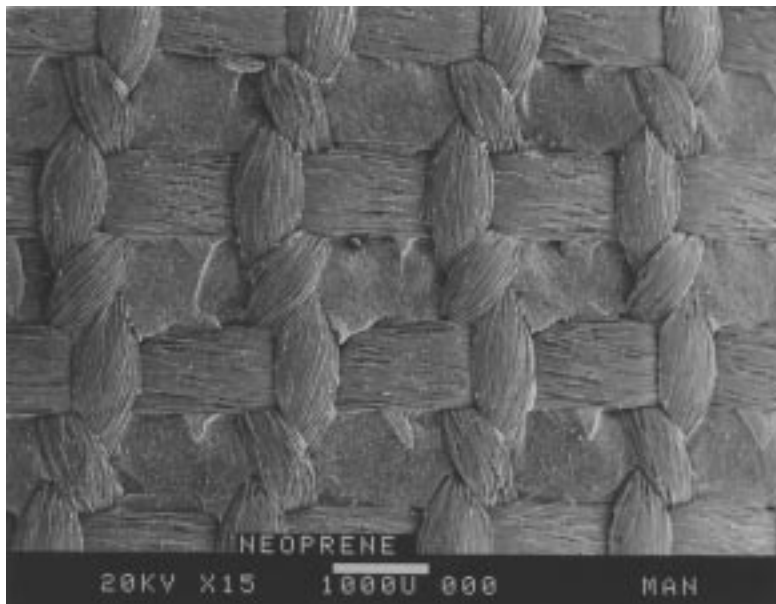

Figure 7-10
SEM Photomicrograph of Neoprene Diaphragm Fiber Weave, Magnification 15x

In addition, the weave patterns vary considerably between the Buna-N and Neoprene diaphragms. The fibers in the Buna-N diaphragm are arranged in a tight over-under orthogonally oriented weave. The Neoprene diaphragm weave has parallel lateral strands with a criss-cross weave evenly spaced between them. The criss-cross weave is more open than the over-under weave and the spacing of the criss-cross weave also leaves large open areas for the Neoprene to bond between the fiber bundles. This is clearly not the case for the fabric in the Buna-N diaphragm. The fabric in the Buna-N has a very low profile with a very dense weave and appears like the fabric one would expect in a windbreaker. The fabric from the Neoprene diaphragm is much coarser, with a deep profile. This fabric is more like a burlap, when compared with the other.

The silicone rubber and Dacron fiber bond was too strong for complete separation of the rubber from the fibers. Figure 7-11 shows an SEM photomicrograph of an exposed section of the silicone/Dacron fiber weave taken at the same magnification as the Neoprene and Buna-N. The surface fibers are somewhat distorted from the removal of the rubber, but the basic weave construction is still visible. This weave combines the regular over-under orthogonally oriented weave of the Buna-N with the thicker fiber bundles of the Neoprene. The open spaces that promote the rubber bond in the Neoprene diaphragm are not necessary in the silicone rubber diaphragm due to the bond between the rubber and fibers.

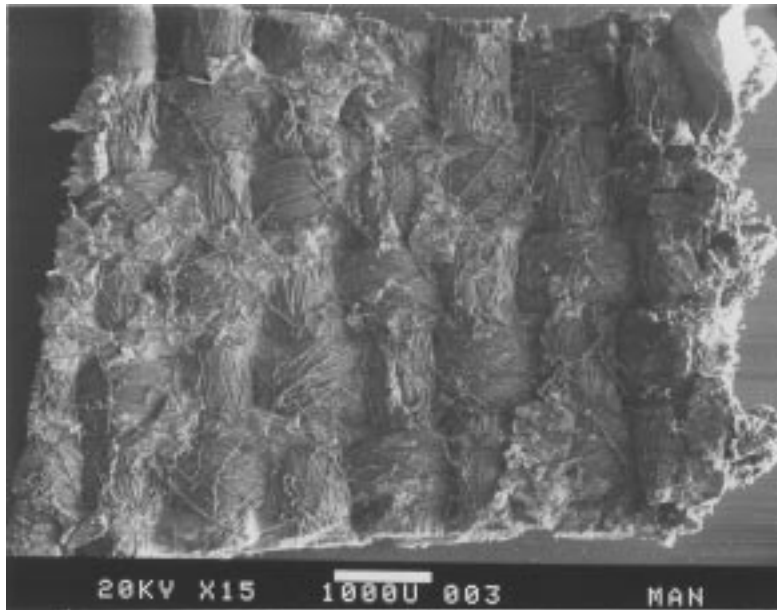

Figure 7-11
SEM Photomicrograph of Silicone Rubber Diaphragm Fiber Weave, Magnification 15x

Aramid fiber weaves, such as Kevlar, are being used to a limited extent in ethylene-propylene diaphragms. Due to the lack of texture of these fibers and their thermoset characteristics, loosely woven fabrics are typically supplied.

Key considerations when choosing the base resin and fiber combination are chemical resistance, operating temperature, bonding characteristics, and mechanical properties. A poor bond between the rubber and fibers is unacceptable in this application because the shear component of the compression stress at the flange edge will cause the two layers to separate. In some cases, the fabric is pre-treated with a low viscosity rubber compound to promote bonding during the molding process.

7.2.6 Service Conditions

AOVs are used for a variety of functions in all types of power plants and systems. Therefore, they are exposed to a wide variety of environmental conditions. Areas near steam lines can be extremely hot; the metal in the pipes and the metal components on the valve housing are good thermal conductors. Not all valves are located inside the plant and those that are outside can be exposed to highly variable temperature excursions.

The diaphragm materials for a specific valve should be selected based on its environment. Areas that are known hot spots would benefit from the added temperature stability of a silicone diaphragm, for instance. In many plants, there are monitors in specific locations to determine the ambient temperature, but the proximity of other equipment can create localized areas of higher temperatures; so it is suggested that the actual temperature in the valve be measured separately, rather than relying on general measurements or predictions of ambient conditions.

Depending on the valve configuration, the diaphragm might be constantly pressurized. Some valves will experience more frequent cycles than others, based on function. The “wear” of the diaphragm should be considered, based on this information. AOVs are comparatively fast-acting valves and their closure can lead to abrupt high stresses on the diaphragm, concentrated along the flange edge, support plate, and interior corner. If there are any questions about a diaphragm from the warehouse and other options are available, that diaphragm should not be placed in constantly pressurized service or in a high-cycle valve. The instrument air feeding AOVs is typically controlled through a pressure regulator to protect the valve from over-pressurization, but the potential for over-pressurization due to a regulator failure should also be assessed when choosing a diaphragm construction.

The rubber is far more susceptible than the reinforcing fabric to the environmental conditions because it is typically a more fragile material and has more exposed surface area with no shielding. Though this will vary by compounding specifics and processing quality, a few general recommendations are valid.

Silicones tend to offer better thermal and chemical stability and would be the recommended choice of polymer for most situations. The primary drawbacks with silicones are their poor tear resistance and low tolerance to physical damage, such as abrasion or over-clamping. Ethylene-propylene rubber offers good chemical and thermal stability, and improved mechanical strength and tear resistance when compared to silicone rubber. Neoprene is more physically rugged than silicone rubber with high tear and

crush resistance and would be recommended for applications where there is a high potential risk for this type of damage. Neoprene should not be used, however, if there is a significant threat of oil exposure because it is prone to swelling upon contact with oil. If the Buna-N has been sulfur-cured properly, this material could offer improved flexibility that would be beneficial in a particularly fast-acting valve.

7.2.7 New Diaphragm Inspection

After receiving a new diaphragm from the manufacturer, there are a few visual clues that provide information about the condition of the part and its manufacturing attributes or defects. The fiber ends are exposed from the reinforcing fabric along the outer flange edge of the diaphragm. Visual inspection of this area allows the assessment of the placement of the fabric between the rubber layers. The fabric should be in the center of the rubber layers and should not exhibit evidence of wrinkling or misalignment that would be apparent from the alignment and placement of the fiber bundles. The surface finish of the component should be visually evaluated to check for evidence of wrinkling of the fabric, exposed fibers on the outer surface, and molding defects such as flash (excess material at the edges), voids, or bubbles. The surface finish should be smooth in all areas.

The diaphragm can also be subjected to a few “scratch and sniff” tests. If the diaphragm has a very strong odor, it could indicate an incomplete cure. The smell is related to the peroxide, sulfur, or other crosslinking agent or synergist that has not been depleted through a complete curing cycle. However, Buna-N rubber has an acrid odor that is characteristic and cannot be avoided.

Another indication of an incomplete cure or poor compounding is the tear resistance of the rubber. Durometer hardness can also be conducted with a hand-held durometer at an area near the edge of the diaphragm to evaluate the comparative hardness of the rubber. Tests and inspection methods outlined in Section 7.5 can be used for further evaluation of the molded rubber components of AOVs.

If it is necessary to take any samples for chemical analysis of the rubber, it is strongly recommended that these be removed from the outer flange edge of the diaphragm with a very sharp scalpel or knife. Most chemical analysis methods require less than 0.2 grams of sample, so small shavings should be sufficient. If significant quantities of sample material are necessary, it is recommended that an extra diaphragm from the same manufacturing lot be purchased for testing purposes to keep the others intact for service. It is imperative that such sampling not adversely affect the integrity of the diaphragm. Cuts must be clean and through the rubber and fabric to avoid pulling fiber bundles from deep within the fabric.

7.3 PACKAGING AND HANDLING

Unlike many metallic components, most polymers are sensitive to elevated temperatures over long periods of time, exposure to solvents and cleaning fluids, UV

degradation, detergents, oils, and other agents. The very properties that allow rubber parts to be flexible make them somewhat fragile; therefore, attention must be paid to their storage conditions. In the same manner that it is necessary to protect steel components from salt water or dissimilar metal contact, it is necessary to protect polymeric components from the above conditions. In many cases, these parts can inadvertently be placed at risk. It is advised that the incoming parts and warehouse conditions be checked to ensure that the following suggestions are observed to improve the likelihood of a functional diaphragm or other soft part with the maximum potential service life.

7.3.1 Packaging Considerations

The diaphragm should be stored in a flat orientation, not folded within its container or rolled. No heavy objects should be placed on top of the diaphragm such that it would be constrained or bent during storage. Clearly marked labels should be visible on the packaging indicating the manufacturer, lot or date of manufacture, and applicable valve size. It is important that such labeling be visible without violation of the integrity of the package.

Transparent packaging is essential to allow visual examination without exposure of the contents to unnecessary dust and handling. The packaging materials should be inspected to ensure that no plasticized vinyls or other plasticized polymers are in contact with the diaphragm. Any packaging materials that exhibit yellowing and/or an oily surface should be removed immediately. Polyethylene bags are recommended.

Plasticizers can degrade many rubber and plastic materials on contact. Materials of this type are used to make vinyl soft. Pressure-sensitive adhesives used in labels or sealing materials also contain powerful plasticizers, so they should not be placed directly on the diaphragm surface. Exposure to paper products should be limited because the sulfates used in paper processing are quite aggressive and can sometimes oxidize elastomers by reacting with moisture to form sulfuric acid. Metallized packages and other opaque materials obscure the diaphragm from view, so it is likely that the package will be opened and closed several times. The absence of packaging materials is not recommended because the diaphragm or other part would receive uncontrolled exposure to dust and vapors. This would prompt a cleaning of the components prior to installation, increasing the chance for an inadvertent solvent exposure.

In an ideal situation, the diaphragm would be placed in a clean, clear polyethylene bag with external labels to protect it from solvent vapors and other dangerous materials.

7.3.2 Environmental Considerations

The diaphragm should not be exposed to elevated temperatures (+120°F) for long periods of time. During summer heat waves, it is possible to have sections of the warehouse where the temperature is not fully controlled, especially areas nearest the roof and walls with full sun exposure. Likewise, certain areas too close to heating vents can get extremely warm in the winter, depending on the configuration of the heating system. Although the diaphragm will most likely be exposed to temperatures much higher than

these in service, it is preferable to protect them from elevated temperatures as long as possible so that premature aging and antioxidant depletion does not occur.

Some mercury lighting systems are a potential threat to polymeric components. By nature, these lights emit ultraviolet radiation. This attacks polymers by chain scission (splitting of the polymer chains) and also promotes oxidative degradation.

Solvents and other chemical substances can degrade diaphragms through direct contact and through vapor exposure. It would be wise to store paints, solvents, oils, and cleaning materials as far from all polymeric components as possible. During all maintenance involving paint or other potential solvent sources, the diaphragm should be removed from the housing if possible. If not, a clean polyethylene sheet should be placed over the diaphragm to protect the rubber until the paint has fully dried. Particular care should also be taken when positioners, vents, and stems are painted.

7.4 INSTALLATION

Installation practices have been directly linked to a number of AOV diaphragm failures and premature degradation of others. Finite element analysis models have shown that the diaphragms are often operating at or near their maximum stress limit (see reference 36, Section 8.0); therefore, even seemingly minor disturbances in the rubber or fiber condition can promote the initiation of a rupture. Over-clamping, field-drilled bolt holes, and flange lubrication are among the observed problems that have led to diaphragm degradation in service. Slightly modified procedures are required for different valve types and sizes, but the following suggestions should be kept in mind to minimize damage to the diaphragm.

7.4.1 Cleaning

Diaphragm surfaces must be clean, dry, and free of any particulate materials. Similarly, the flanges must be completely clean and free of rust, burrs, or other surface anomalies that will impair sealing. It should be noted that small bits of debris can penetrate into the elastomer, compromising its sealing characteristic or, in a worst case, serving to initiate a tear. The diaphragm must be flat against the flanges before tightening the bolts; otherwise, wrinkles can occur. The diaphragm must not be twisted, pulled, or otherwise distorted during installation to avoid wrinkles and to ensure uniform distribution of mechanical stresses.

If the housing threads have been lubricated, lubricant residue must be removed from the flange faces and from the diaphragm surface. Cleaning with a mild soap or with a cloth wetted with ethyl alcohol is not harmful, although a dry cloth should be attempted first in all cases. Denatured alcohol must be avoided because it is formulated with benzene, a solvent that can promote severe degradation of diaphragms and seals.

7.4.2 Clamping

The clamping process should be reviewed because it can compromise the damage or defect tolerance of the diaphragm and might adversely affect its sealing characteristics. It is important that rubber components be compressed to ensure a leak-tight seal. Crosslinking prevents gross plastic deformation of elastomers, but it is not possible to effectively achieve crosslinking densities above approximately 85% for most elastomers. This leaves a fair amount of the elastomer in a non-crosslinked form in which it is subject to permanent plastic deformation.

A compression of 10-20% is normally used to seal rubber-gasketed surfaces, although the specific compression value is dependent on the materials, flange design, application, and manufacturer's specifications. Excessive clamping force becomes self-defeating when the gasket material plastically flows, thus reducing the compression force at the interface. Excessive clamping can also promote shear separation of the rubber/fabric interface, allowing the fabric to pull out from the rubber when the diaphragm is pressurized. In the event of a leak, re-torquing of the housing bolts is not recommended because this could promote compression fractures or creep damage of the diaphragm.

Although there is debate over the bolt tightening procedures, a safe practice is to use a one-quarter turn sequence after the gasket/diaphragm has been contacted. The final setting should be established with a torque wrench to ensure uniform compression force for all bolts. All nuts and bolts must be clean and free-turning by hand. If a lubricant is necessary, this **must** be limited to the threads and all bolts must be so treated. This also provides a safeguard against missing one or more bolts if manual torquing methods are used. After all bolts have been tightened to a predetermined limit, each bolt should be backed off one-eighth turn and re-torqued to a uniform setting, in sequence. There is a tendency to over-clamp with the intention of creating a tight seal, but there is a thin line between a proper seal and extreme compression of the part. Suggestions for evaluating clamping damage are provided in Section 7.6.2.9. It is extremely useful to examine some parts recently removed from service to determine how the present plant practices are affecting the diaphragms.

7.4.3 Bolt Holes

In some cases, the diaphragm does not have enough bolt holes to accommodate replacement valve housings. Because of the presence of the fiber weave, adding a bolt hole should be performed only with a punch. Drilling the holes can lead to pulling the fibers out of the rubber matrix as shown in Figure 7-12. Entanglement and winding of the fibers on the drill bit causes them to pull away from the rubber matrix and reduces the tensile strength of the diaphragm. The rubber in this area becomes unsupported and has significantly reduced mechanical properties when compared with rubber in other areas. The new drilled bolt holes tend to elongate during service as they are stressed, eventually creating a leak path or a rupture initiation site if the rubber becomes too thin.

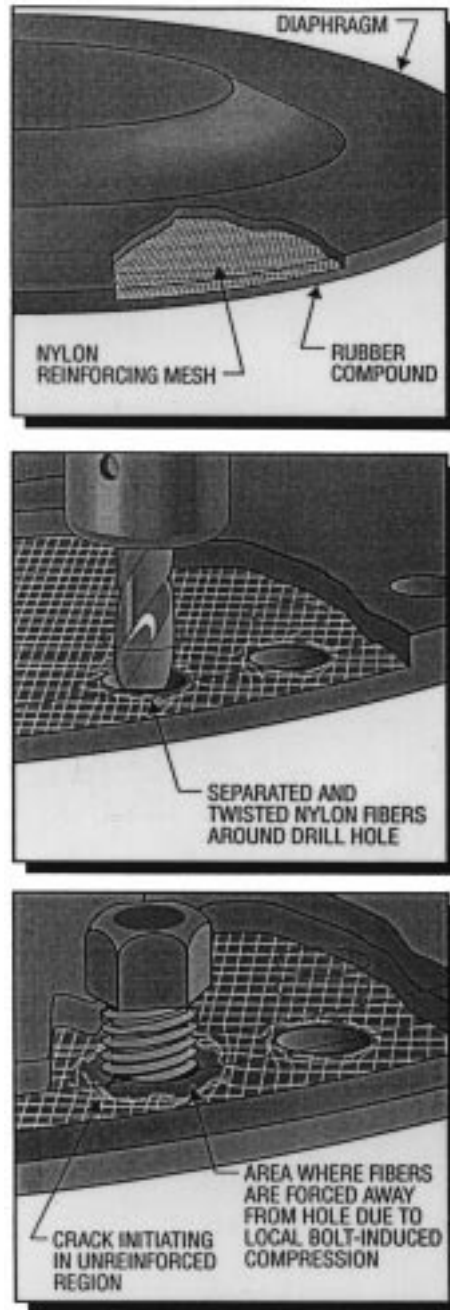

Figure 7-12
Illustration of Fiber Damage from Field Drilling of Bolt Holes

If additional bolt holes are necessary, a punch and die set should be purchased or made in a machine shop. Carbide or case-hardened materials with an extremely sharp cutting edge are recommended. The sharp edge causes minimum deformation of the fibers and rubber.

7.4.4 Lubrication

If the diaphragm has been properly installed, lubricants and thread sealants should not be necessary. These materials should be avoided if at all possible due to their potential for harmful interaction with the diaphragm rubber and their interference with sealing and mechanical constraint of the diaphragm.

Silicones are commonly used for many plant components as a good high temperature lubricant. Depending on the specific chemical formulation, many of these products can degrade the diaphragm rubber compound by dissolving out processing aids such as zinc stearate or a phenolic antioxidant. Silicones are available in two common forms; polydimethyl silicone or polymethyl/phenyl silicone. For application to rubber components, it is recommended that lubricants containing phenyl silicones be avoided due to their propensity to promote swelling and softening. Further, silicone lubricants are commonly supplied in pressurized spray canisters. It is imperative that the propellants and solvents be considered when using such lubricants. Nitrogen, ethanol, butane, pentane, and others provide benign propellants and solvents for the oil. Lubricants containing stearic acids, non-identified petroleum distillates, and wetting agents should be avoided. The Chemical Rubber Company (CRC) provides excellent disclosure of all ingredients in its line of lubricants.

The presence of most any lubricant at the flange edge of the housing is undesirable due to concerns with the friction retention of the part. Slipping of the diaphragm transfers and concentrates the axial stresses in the diaphragm to the outer edge of the bolt holes. These materials could also interfere with the sealing characteristics of the diaphragm due to slippage or leakage. Lubricants that contain hard particles, such as graphite, are a particular concern with respect to leakage. It should also be noted that lubricants that are not applied directly but near the flange area could easily migrate to this region at elevated temperatures.

Thread sealants are sometimes applied to the threads of the stem bolt in an effort to reduce leakage. These materials should be unnecessary for properly installed parts with good surface finish. Sealants could restrict the movement of the diaphragm during actuation increasing the stress in constrained areas. Many sealants contain volatile organic compounds that might condense in areas where they could degrade polymeric components or sliding metal surfaces.

7.4.5 Valve Housing Considerations

The flange surface should be visually examined to make sure that there are no burrs or other sharp features that could potentially puncture the diaphragm. The alignment of the two flanges should be concentric to avoid the non-uniform distribution of mechanical stresses. Flanges must be flat and should be checked for run-out against a flat reference surface. The bolts should also be free of burrs or surface roughness and of a shoulder-type design. The threads on the bolts should fit easily within the diaphragm bolt holes to avoid cutting the rubber layers. All nearby surfaces in the valve housing should

be examined to ensure that they are clean and free of debris, solvents, or lubricants that could contact the diaphragm and impair sealing or degrade the diaphragm materials.

7.5 MAINTENANCE

Proper maintenance of AOV diaphragms consists primarily of regular inspections and avoiding certain practices, rather than adopting a large dedicated maintenance program. The response of individual diaphragms can be expected to vary due to local environmental conditions, variations in assembly practices, and variations in materials and construction. When the integrity of an AOV diaphragm or other flexible soft part has been compromised, it should be removed from service. There is no way to patch, fix, or otherwise reverse the effects of accumulated damage and aging to most of these parts in a manner that would restore the component reliability. Maintenance practices, however, can be adopted to efficiently extend the reliable service life of AOV elastomeric components.

7.5.1 Inservice Inspection

Plant operation and maintenance records are useful in determining which AOV diaphragms are most vulnerable to degradation. If the instrument air pressure regulators, nitrogen pressure back-up system, or other attached systems have not been operating properly, an AOV diaphragm on the same system might have been exposed to excessive pressures. Although it is difficult to correlate temperature data to the actual conditions at the AOV diaphragm, if records indicate that a particular area of the system has been running hot, this would be a good location to inspect diaphragms with increased frequency and attention to detail. Valves that have been part of maintenance activities or repair should be inspected due to the diaphragm's sensitivity to mechanical damage.

AOV diaphragms can also be subject to accelerated degradation due to inadvertent exposure to oil, water, and other materials associated with the instrument air system. It is important to note that despite significant improvements to instrument air systems at most plants, prior oil and moisture exposures due to earlier system designs can be expected to have an effect on the aging of components that have not been replaced. The following might be considered:

- Unusual accumulation of oil in dryers, filter housings, and moisture separators might prompt an examination of a representative AOV diaphragm/housing for oil intrusion.
- Water found in filter housings and drier systems should be subjected to a simple field pH test to determine if unusual acidic or alkaline conditions exist; if so, corrective measures might be taken with the instrument air purification system, using commercially available products.

- Any recent painting, solvent cleaning, oil spills, diesel fuel spills, or other potential sources of hydrocarbon residues should be taken into account as potential contributors to diaphragm degradation. In such a case, a simple chemical analysis of water or oil removed from the air dryer system can determine if residues have been concentrated in the instrument air system.
- If there has been a recent history of air pressure regulator problems or other premature degradation of polymeric materials associated with the instrument air system, this should prompt a review of the potential effects on the AOV diaphragms.
- Damage or degradation of desiccant materials, filtering media, and visual indicating materials should be noted. Desiccating material released into an instrument air system might allow hard particles to interfere with proper operation of air pressure regulators, for example, possibly leading to over-pressurization of AOVs.

To perform a thorough examination of the diaphragm, the valve has to be taken off-line and the diaphragm must be removed from the housing. During service, in some valve configurations, a small portion of the non-pressurized face of the diaphragm is exposed through the housing vent. This area provides a limited view of the diaphragm, but with a mirror and a flashlight or "borescope," a quick visual examination of a good deal of the center portion can be conducted while the valve is still in service. This method would be particularly useful in examining for crazes, wrinkles, blisters, discoloration, or other surface damage. It is also possible to view the exterior of the housing and flange edge which provides some opportunity for inservice inspection (ISI). Corrosion damage would be a potential concern because this might contribute to premature mechanical degradation of the diaphragm.

If the diaphragm has been removed from its housing, it should be visually examined to determine if there are any indications of severe aging or damage. The rubber should be smooth with no evidence of swelling or residues, such as oils or paints on the surface. If oils or paints are present, those areas should be closely examined for crazing and swelling. The bolt holes should be concentric with limited deformation from the clamping process. The flange area of the diaphragm will experience some permanent set, particularly with Buna-N rubber, but this should not be greater than 20% of the original thickness of the part.

The diaphragm should be folded to ensure that it is still flexible and to check for evidence of crazing. Crazes are a common indication of chemical or thermal degradation of rubber parts. They will be present in the form of small cracks along the surface of the rubber and usually run perpendicular to the direction of the highest mechanical stresses. In many cases, crazes are not readily apparent until the diaphragm is flexed. Both faces of the diaphragm should be checked because chemical exposure is likely to be more severe on one side of the diaphragm. Craze penetration on both sides of the diaphragm also indicates that the attack has progressed through the thickness of the part and that leakage has started or will be starting soon if the part remains in service.

The surrounding areas of the valve housing, including the flange surfaces, should be examined for indications of unusual wear or lubricant residues. In cases where a Neoprene diaphragm has been selected, the presence of rust or other forms of corrosion are an indication that the Neoprene is thermally breaking down to form reactive chlorides. This typically occurs at 130°C or more. Neoprene is a DuPont trade name for chlorinated polyethylene. Excessive temperatures can cause the release of hydrogen chloride, which will degrade many metallic parts by formation of hydrochloric acid in the presence of moisture. In this case, corrective actions should be taken to remove the corrosive products from the valve housing, and the diaphragm should be replaced for the current operating conditions, preferably with a more thermally stable material, such as silicone or ethylene-propylene rubber.

A check list of areas to inspect is provided in Table 7-1 for reference purposes. This list should be considered a general guide, and site-specific considerations should be added by plant personnel as necessary.

**Table 7-1
In-Service Inspection Check List**

<ul style="list-style-type: none"> Examine the edge of the diaphragm where it protrudes from the housing:
<p>Observe for a pattern of cracking or crazing; if present, a small flake of material can be chemically analyzed to determine the root cause without removing the diaphragm from service.</p>
<p>Flex the diaphragm edge; if it is brittle, an examination of the diaphragm would be prudent at the earliest possible opportunity</p>
<p>If the edge is "gummy," oil exposure, improper cure, or other significant degradation might be occurring. Chemical analysis of the rubber would be urged and inspection of the internal portion of the diaphragm would be indicated as soon as possible.</p>
<p>If the edge is bulged significantly, this might indicate over-tightening of the flange bolts. Such a condition can lead to tears of the diaphragm originating at the bolt holes in service.</p>
<p>If the edge is non-uniformly compressed, this indicates non-uniform tightening of the flange bolts. This condition can lead to tears of the diaphragm at the overly compressed side.</p>
<p>If the edge is "tucking in" between the bolts, under-tightening might be indicated. This condition could lead to a tear in service and should gain immediate attention. Loosening the bolts to alleviate such a condition is not recommended.</p>
<ul style="list-style-type: none"> Leak testing (air in or air out) is easily accomplished using a commercial leak detecting fluid, such as Snoop® or a dilute solution of glycerin and distilled water. If newly installed, flange bolts can be tightened to correct a leak, as long as compression limit guidelines are not exceeded.
<ul style="list-style-type: none"> In most cases, the fabric reinforcement can be seen at the periphery of the installed diaphragm. Some conditions and their possible adverse ramifications follow:
<p>Fabric exposure on one face of the rubber can promote air leaks; over-tightening can be a natural reaction.</p>
<p>Significant wrinkling of the fabric can promote non-uniform mechanical stress distribution in the diaphragm, possibly leading to rupture.</p>
<p>Fabric "pulling in" non-uniformly would indicate poor bonding, non-uniform tightening, over-tightening, or other adverse condition; the expedient corrective action would be indicated.</p>

7.5.2 Cleaning

If necessary, the diaphragm surface can be cleaned with a mild soapy water, followed by a rinse with clean, non-soapy water. The adjacent areas of the valve housing should also be cleaned using only soapy water or a mild degreaser that does not leave an oily film. Chemical cleaners, solvents, and particularly aerosol cleaners should be avoided in and around AOVs. The newer generation of citrus oil-based cleaners can be used, but the oil that remains can cause significant softening (plasticization) of the diaphragm. A clean, dry cloth is effective in removing residues from this type of cleaning agent.

Even if cleaning materials do not come into direct contact with the diaphragm, they are not recommended because their solvent vapors can still contact and degrade the rubber. If the valve housing needs to be painted, it is recommended that the diaphragm first be removed and placed in a polyethylene bag to protect it from solvent vapors. The diaphragm should not be installed until the paint is completely dry and odor-free.

7.6 FAILURE ANALYSIS

Analysis of failures and significant premature degradation of AOV rubber components is important for determining if the cause is related to the materials, manufacturing, installation practices, or plant conditions. Failure analysis can be complex in some cases, but relatively simple in others. This section addresses a wide range of tests and inspections that can be useful for root cause determinations. It is imperative that the reader understand that no such discussion can possibly encompass all possible failure mechanisms nor can such endeavors be treated as simple “procedures.” On the other hand, experience, intuitive skills, and basic knowledge of materials and their degradation mechanisms can greatly increase the potential for plant personnel to significantly improve the longevity and reliability of AOV components.

7.6.1 Evidence Preservation

When a failure occurs, it is important to have a properly trained response team or identified personnel to increase the chances of a correct root cause assignment for the event. During removal of the affected component, it is essential to leave it in its present (as-failed) condition to the maximum extent possible, minimizing its exposure to solvents, fingerprints, lubricants, and mechanical stresses. If a diaphragm is found to have stuck to its housing, pulling it off manually would most likely compromise the value of the sample for subsequent condition assessment. Instead, the diaphragm should be peeled off with a brass scraper or other suitable tool. A simple scraper can be made from a sheet of polycarbonate or Plexiglas[®] plastic, for example, by creating a beveled edge using a file, grinder, or bandsaw.

It is recommended that detailed photographs of the interior of the actuator housing and diaphragm be taken during removal, focusing on the surface finish of all parts, the presence of any foreign substances, and the area of the diaphragm failure. Good quality lighting and appropriate film are recommended so that the recorded colors are accurate.

Distinguishing “rust stains” from other surface films and deposits might become important at a future time and the photographic record would be most useful if carefully prepared. During latter stages of the investigation, recalling whether the diaphragm was wrinkled might be important, but otherwise difficult to recall unequivocally without a photographic record.

The condition of the bolts should also be noted to determine if they were free, galled, cross-threaded, or distorted. As a minimum, a visual inspection of these parts should be conducted, and documentation should be provided with the failed diaphragm when it is submitted for analysis.

The diaphragm should be stored flat without folds after removal from the housing. Although it is often tempting, flexing of the diaphragm and handling of the area near the rupture or other observed damage should be kept to a minimum until the diaphragm has reached the parties responsible for the root cause analysis if they are not present at the disassembly of the actuator. If possible, it would be best to seal the diaphragm in a clean polyethylene bag or polyethylene sheet. Other bags might have been formed from vinyl polymers that may contain plasticizers (chemical softening agents), which might adversely interact with the diaphragm materials.

It is understood that during an unexpected outage, rapid response is key in restoring the plant to operation, but a few extra minutes to ensure that the failure scene is handled properly could lead to a root cause analysis that will enable the detection of other component problems before another failure occurs. Labeling of components becomes particularly challenging at such times.

Any fluids found on or near the diaphragm should be collected and stored in glass jars with a Teflon™ or polyethylene-lined lid for future analysis if necessary. Lids of this type help to avoid contamination from cardboard, corrosion products from aluminum foil, or products from other traditional seals and liners that could confuse the chemical analyses. Other samples of associated debris present in the area of the diaphragm should be stored in jars or polyethylene bags, depending on their size and the available materials.

Records pertaining to the operation of the valve before and up to the failure event should be gathered and reviewed. Valve temperature, number of cycles, line pressure, and any other available information could provide information about the contribution of related systems to the failure. Over-pressurization events, high frequency of interrupted cycles, or local temperature excursions could all contribute to premature aging of the diaphragm. Reviewing such information in context of diaphragm performance would be particularly helpful in identifying other valves in the same system that could be at risk.

7.6.2 Test Methods

A variety of test methods are available to assess the condition of AOV soft parts. These range from simple visual and tactile examination to more sophisticated mechanical and

chemical testing methods. The following testing method descriptions begin with methods that are applicable in the plant environment, and then lead into laboratory-based methods that might be necessary for selected failure analyses. It is not anticipated that the reader would necessarily conduct the full range of laboratory tests, but these descriptions should be useful in arranging for and interpreting the results from such tests.

7.6.2.1 Visual Examination

The most important part of any investigation is the preliminary visual examination. It is necessary to evaluate the component condition and determine the best use of the remaining material in terms of sample selection and analytical methods. It is also imperative that representative areas be selected and that the samples be prepared in a manner that does not influence the test results. Thorough documentation of the part should be conducted so that the original as-failed condition can be reconstructed at a later time, if necessary. This evaluation should help to guide the selection and order of test methods as well.

Visual examination begins with overall characterization of the diaphragm surface. The surface should be smooth, reasonably shiny, and free of crazes, voids, blisters, oily films, wrinkles, or cuts. Some areas might have an impressed texture that results from prolonged contact within the housing and along the clamped edge. The periphery should be carefully inspected for the presence of tears, cracks, embedded rust flakes, embedded debris, or other damage. Degradation found during this inspection can be further characterized by microscopic methods.

The diaphragm should be characterized for its overall geometry. It should be wrinkle-free and it should lie flat. Any deviations should be noted. The holes along the bolt flange should be round and concentric. Any elongation should be noted and characterized as to whether the elongation is radial, axial, and/or symmetric. The center hole should also be examined to be certain that correct installation practices were used. A non-concentric compression pattern where the support plate was located would be an example of evidence of poor installation. Oil and grease films on the diaphragm surface should be noted, characterized, and preserved.

The interior surface of the housing should also be inspected as soon as it is opened. This should be examined for the presence of water or oil because these are ready indications of instrument air system problems. Similarly, rust deposits might indicate moisture accumulation or acidic conditions.

7.6.2.2 Non-Instrumental Screening Tests

While many of the materials and degradation processes can be complex, there is no reason why a number of simple screening evaluations cannot be effectively applied for a field assessment of the condition of diaphragms. Someone familiar with the “feel” of a new diaphragm might be able to determine from a simple manipulation that a diaphragm being removed seems “harder” than the original. Such an observation is extremely valuable and must not be discounted in consideration of more exotic testing. In

Table 7-2, a number of simple tests and their application have been outlined. These are particularly useful for the initial screening of a failed diaphragm or for the evaluation of non-failed diaphragms as part of an inservice inspection program.

Table 7-2
Simple Field Tests for the Initial Evaluation of AOV Diaphragms
and Other Elastomeric Components

Observation:	Changes Might Indicate:
Flex and inspect for surface crazing	Oxidation, radiation damage, thermal damage, solvent attack
Flexibility	Extent of cure (more decreases flexibility), thermal degradation, radiation damage, solvent damage
Shrinkage of rubber at edges	Improper molding, chemical attack, radiation damage, over-tightening, thermal damage
Discoloration	Improper formulation, rust staining, chemical attack, foreign material
Cracks	Thermal damage, chemical attack, aging
Impress fingernail; observe indentation recovery (full, slow, none)	Compression set resistance (affected by formulation, aging)
Fold over, test deformation resistance	Extent of cure, chemical damage
Surface finish	Molding quality, rubber compound mixing/preparation, chemical or thermal attack
Surface "chalking"	Severe chemical attack, severe thermal damage, paint deposits
Surface waxy residues	Mold release or antioxidant bloom
Strong chemical odors	Chemical attack, thermal damage, nitrile rubber (inherent odor)
Notch, test tear resistance	Extent of cure, chemical or thermal damage
Moisture beading behavior	Decrease suggests thermal damage
Surface texture	Compression damage, molding defects
Adheres to housing	Rubber formulation, oil attack, chemical attack

7.6.2.3 Microscopic Examination

Optical microscopic examination of the rubber can be used to evaluate the condition of interfaces between the rubber and fabric, to detect the presence of voids or contaminants, and to evaluate the dispersion of ingredients within the compound. This method is also useful in determining the extent of crazes, fractures, or other damage to the rubber, particularly in evaluating the extent of penetration of surface crazes into the diaphragm.

The integrity and alignment of the fiber core can be inspected by removing small areas of the overlying rubber layers. In many cases, the rubber is difficult to remove from the fibers, due to the strong chemical and mechanical bond that is formed upon curing. Liquid nitrogen is often helpful for sample preparation.

Due to significant differences in thermal expansion coefficients, the rubber and fabric layers might spontaneously separate upon freezing, allowing easy removal. At least, the materials are made tougher when frozen, allowing the layers to be pried apart more easily. Heat should not be used because this chemically affects the materials, and the rubber cannot be melted due to the chemical crosslinking that was used to produce the diaphragm. The use of freezing techniques also minimizes surface distortion that can occur due to plastic deformation.

Defects in the dispersion of the rubber ingredients might be evident or suggested by the presence of tiny blisters filled with white, black, or gray powdery materials. These might be apparent on the exterior surface, but can also be seen in cross-section when a surface is adequately prepared. Cutting with a single edge razor blade can afford a limited look at a cross-section, though the surface will be smeared in the process and some evidence might be masked. Preparing a cryo-fractured surface is preferred. This simply involves freezing a small section of a diaphragm in liquid nitrogen (2-3 minutes immersion), and then sharply bending it immediately after removal. This yields a non-disturbed cross-section, ready for examination by eye, hand magnifier, or stereomicroscope.

Non-dispersed ingredients are an indicator of improper mixing of the rubber compound. Compounds are only as good as the mixing of their components. Segregated components are not available to interact with the system.

Voids might be apparent on the surface of the diaphragm as-found or when stretched. Voids can also appear in the cross-section when not apparent on the surface. Diaphragms can be evaluated for the presence of internal voids by preparing cryo-fractured surfaces with subsequent visual examination supplemented with a hand magnifier or stereomicroscope. Voids are possible indications of excess moisture of the compound during cure, excess rate of crosslinking, incomplete mold filling, significant solvent interaction, or other defects. Optimum mechanical strength and lowest leak rates are ensured with void-free compounds.

7.6.2.4 Hardness Testing

Durometer hardness measurement of the rubber is a relatively simple test that can be used comparatively to evaluate embrittlement, oil attack, chemical degradation, or other aging-related damage. The ASTM specification for rubber hardness testing, D2240, requires a material thickness of at least 0.25 inch to be used. The diaphragm rubber layers are not thick enough for this specification, so the results should be used on a comparative basis only with new diaphragms made with similar materials or with spare diaphragms of the same vintage that have not been in service. The best results can be obtained by stacking layers of the same diaphragm, being careful that each represents an area with similar characteristics. For example, the relatively protected center area of

the diaphragm under the support plate can be used as a reference sample when degradation due to chemical or solvent attack is suspected.

7.6.2.5 Chemical Analyses

Chemical analyses of the rubber can take many forms. Chemical identification of the rubber and fiber major organic chemical functional groups can be conducted with micro-Fourier transform infrared spectroscopy (FTIR). This method is also useful for the identification of non-dispersed ingredients and contaminants and for detecting the presence and location of oxidized areas on the diaphragm surface. For more detailed analysis of the organic rubber compound ingredients or specific contaminants, the combined methods of gas chromatography and mass spectrometry (GC/MS) are suggested. This method is more time consuming and complicated, but it is far more sensitive than FTIR for the detection of solvents and thermal breakdown products.

For GC/MS analysis, a small section of diaphragm material is required. This can then be immersed in a solvent, such as methanol, for an extended period (for example, two hours) to extract organic compounds. This extract is then injected in a heated (vapor) form into the gas chromatography column. The column consists of a very long, small bore tube with an inner surface treated with a porous silica. It is used to separate the larger and smaller compounds, based on their molecular weight. At the end of the column, a detector determines when each component passes through. A mass spectrometer is used in the GC/MS technique to determine the mass of each compound as it comes out of the separation column. Using the combined data of retention time in the column and the mass, compounds can be identified with near absolute precision, with very high sensitivity.

Sampling methods also include direct thermal desorption. In a case where a diaphragm was suspected to have sustained solvent exposure, traces of the solvent can be detected by placing a small section of the diaphragm into a heated chamber at the entrance to the column. A purge gas, such as nitrogen, is passed through the desorption cell, carrying with it the gases removed from the diaphragm upon heating. This mixture then passes through the column, allowing identification of the offending solvent.

Infrared spectroscopy must be conducted using a reflectance mode due to the opaque nature of diaphragm compounds. For this, small sections of the diaphragm can be removed and handled to avoid surface contamination. An infrared spectrometer then illuminates the surface with a broad spectrum of infrared radiation while measuring absorbency for each wavelength of the infrared spectrum. Each organic chemical functional group has a unique absorbency, so the absorbencies can be used to identify contaminants, oil films, and oxidative degradation, and to analyze the components blended into the rubber compound.

7.6.2.6 Crosslinking Density (Cure Assessment)

The degree of crosslinking can be assessed following ASTM D-2765. As part of this procedure, a small amount of the rubber is “ashed” in an oven to determine the percentage of inorganic materials in the compound. Ashing is the common term used to identify the process in which the polymer and organic additives are burned away, leaving the inorganic filler and reinforcement materials.

Measurement of the inorganic portion of the rubber compound is recommended because an increase in the concentration of inorganics is an indicator of misformulation or removal of the rubber. An increase in the inorganics accompanied by an increase in the crosslinking density of the rubber indicates that potentially the non-crosslinked portion of the rubber was chemically or thermally removed during service. Samples for both of these tests should be removed from a relatively non-damaged area of the diaphragm and near the failure site for comparative purposes. Areas that might be away from the failure area but appear to be crazed or swollen would also be good candidates for this test to assess the degree of damage.

7.6.2.7 Scanning Electron Microscopy and Elemental Analysis

In some cases, a very detailed examination of a specific defect or damage site is necessary to determine the root cause. Although magnifiers or stereomicroscopes are very powerful forensic tools, each is limited in its ability to determine such things as fine surface details at a tear or the characteristics of the ends of individual broken fibers in the reinforcing fabric.

In such cases, a scanning electron microscope (SEM) is essential. This instrument creates an image from a surface by scanning an electron beam over it, using reflected electrons or electrons emitted from the sample surface to create images with high magnification and depth of field. Surface details of the rubber at a tear can be characterized to determine if the tear resulted from a tensile overload, chemical attack, embrittlement, improper manufacture, or impact damage. Fracture/tear surface characteristics are often complex and beyond the scope of this guide, but suitable references are provided in Appendix L.

An example of a solvent-attacked diaphragm is provided in Figure 7-13. In this case, pores within the rubber have been created when the solvent dissolved and removed the rubber, leaving behind the inorganic ingredients blended into the rubber compound. In Figure 7-14, a torn surface of a diaphragm is shown. The “wavy” surface features are indicative of a tensile overload, and their orientation indicates the direction of tear propagation. For comparison, a cut surface of a diaphragm is shown in Figure 7-15. In this case, the surface is very planar and free of the patterns shown on the torn surface. In Figures 7-16 and 7-17, nylon fabric fibers with cut and torn ends are compared. The distinction between the damage mechanisms is clear and unequivocal in these examples.

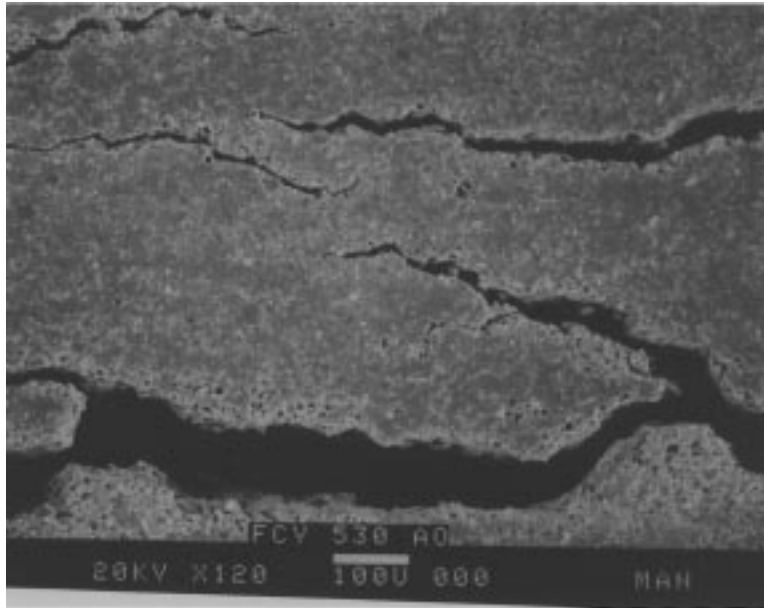

Figure 7-13
Solvent-Attacked Diaphragm, Showing the Porosity
Resulting from Dissolution of the Rubber

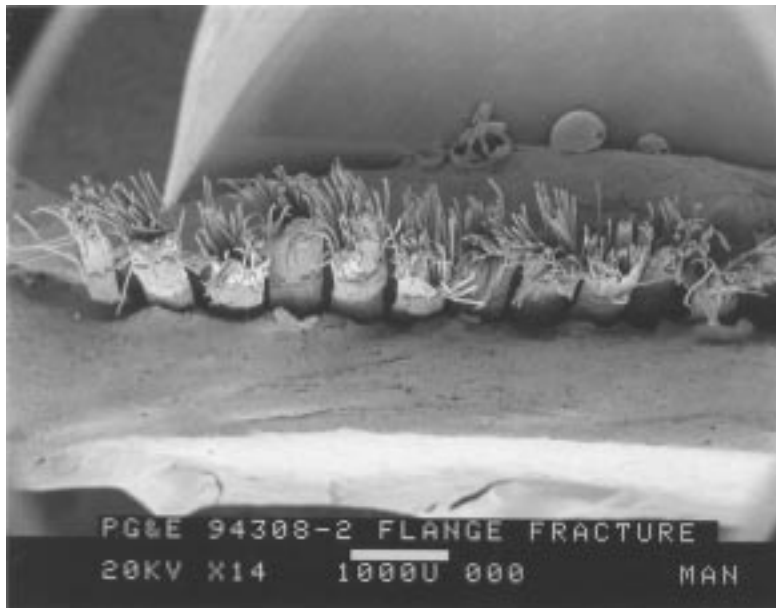

Figure 7-14
Surface Details at a Diaphragm Tear

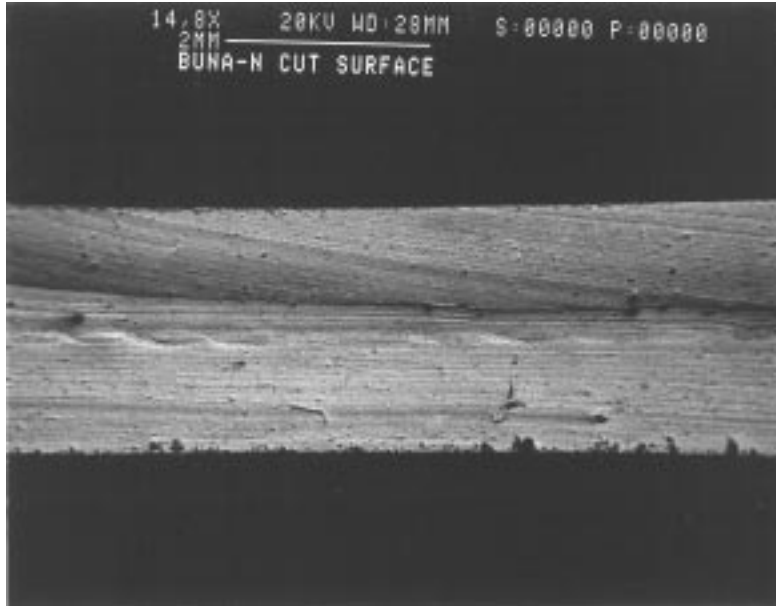

Figure 7-15
Surface Details at a Cut in a Diaphragm Surface



Figure 7-16
Nylon Fibers, Showing the Surface Details
Resulting from Cutting Damage during Installation or Handling



Figure 7-17

Surface Details at the Torn End of Nylon Fiber, Resulting from Tensile Overload

The electron beam used in the SEM has sufficient energy that it causes the sample under investigation to emit X-rays from its surface. Through the use of an energy dispersive X-ray spectrometer (EDX), the energy of these X-rays can be measured. Each element emits X-rays that are characteristic of that element, so the energy can be used for chemical analysis. This tool is particularly well suited to analysis of inorganic compounds. In the case of diaphragms, improper blending of clays, zinc oxide, lead compounds, and others can be easily detected. Combining the X-ray analysis and imaging capabilities of the SEM, a powerful forensic tool is available that allows inspection for defects and damage with localized chemical analysis of the same areas.

7.6.2.8 Mechanical Testing

Mechanical testing can be used to evaluate the tensile and elongation limits of the rubber and fibers. This testing is a bit challenging due to the significant dependence on fiber orientation. The standard “dogbone” samples can be removed from the diaphragm center and from the interior corner of the diaphragm to compare a flat region with a highly stressed area. All samples from the interior corner, however, should be punched such that their gage section is over the interior corner, not the grip section of the samples. An illustration of this is shown in Figure 7-18.

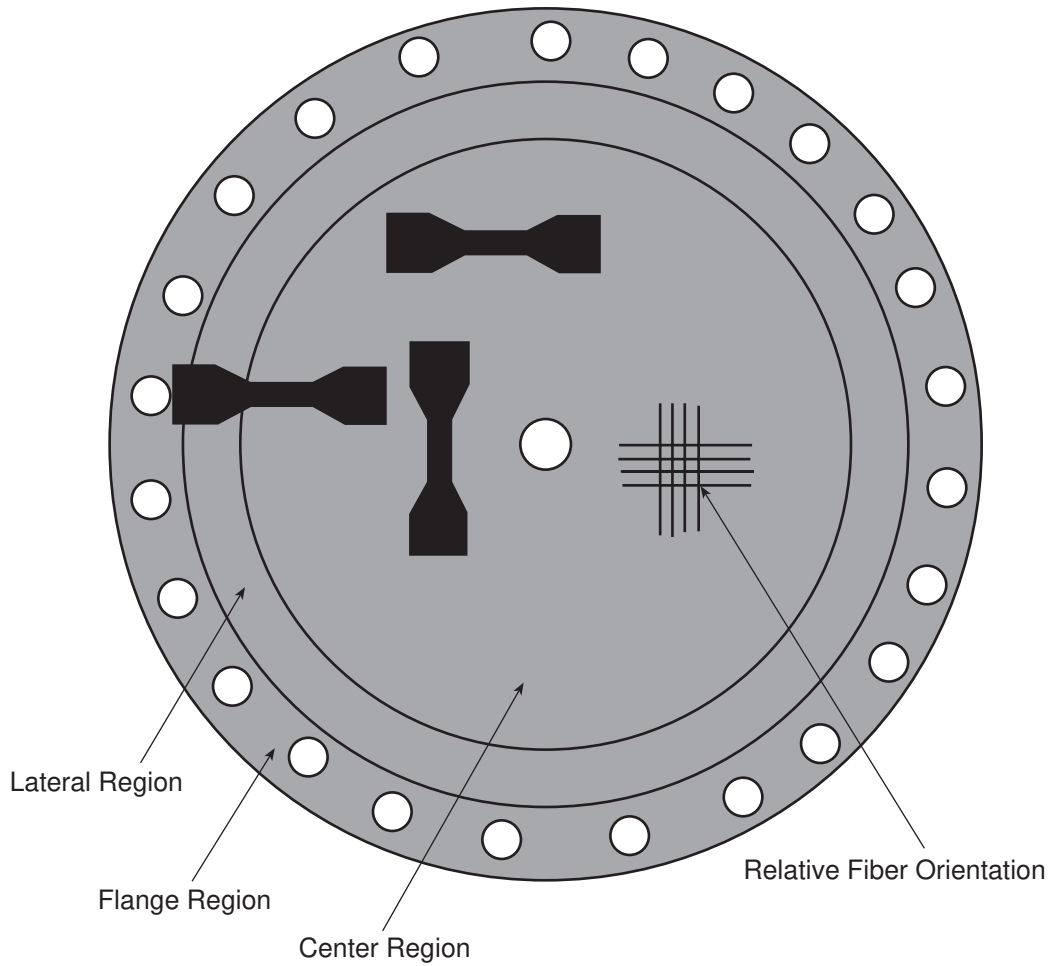

Figure 7-18
Location of Tensile Samples for Mechanical Testing

The tensile and elongation values should be considered separately for the two materials. The first peak corresponds with the maximum tensile strength and elongation of the fibers. The second peak, or final break of the sample, corresponds to the maximum tensile strength and elongation of the rubber. For some rubber materials, Neoprene, for example, the rubber might elongate past the maximum extension of the load frame. In this case, it would be safe to assume that the rubber has not lost its flexibility due to aging or degradation, and precise values are not necessary. A representative graph showing tensile and elongation for a Buna-N diaphragm sample is presented in Figure 7-19.

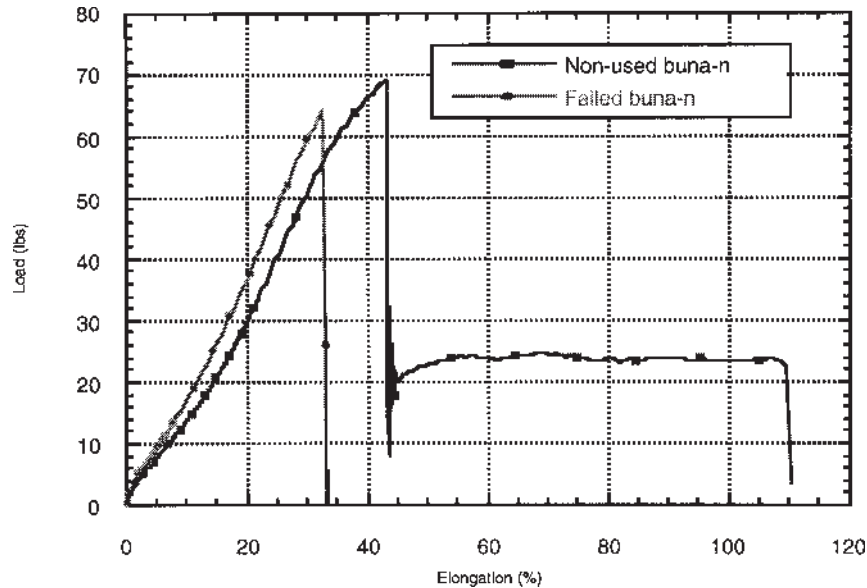

Figure 7-19

Load vs. % Elongation for Sample from Failed Buna-N Diaphragm and Non-Used Diaphragm from the Same Manufacturing Date

7.6.2.9 Thickness Profile Measurement

Thickness profile measurements are also recommended to determine the maximum clamping-induced deformation of the flange edge of the diaphragm. Measurements can be taken at 0.06 inch intervals on 2-inch-long, narrow radial sections taken from the flange edge of failed and spare diaphragms for comparative purposes. Limited deformation is expected from normal usage, but gross deformation indicates that the diaphragm materials and clamping procedures are not compatible. Though the surface of the diaphragm in this area often looks non-damaged with the exception of some plastic deformation, the condition of the fibers underneath the rubber, which are the primary source of tensile strength for the diaphragm, are most likely over-stressed and damaged from the deformation, which can lead to a rupture and subsequent valve failure over time.

7.6.2.10 X-Radiographic Inspection

Radiographic inspection is a valuable tool for examining the internal structures and defects for a wide range of materials in a non-destructive manner. In the case of diaphragms, though, the X-ray density differences between the rubber compound and fabric reinforcement are so small that they cannot be effectively distinguished with this method. Radiographic inspection offers limited internal visualization of large voids and fabric folds, for example, but long exposures at very low X-ray energy levels are required. The most effective imaging is obtained using a beryllium X-ray source. X-ray tomographic imaging has not been shown to offer any significant advantages when compared to traditional film methods.

7.6.2.11 Ultrasonic Testing

Limited inspection of the internal condition of diaphragms is possible with ultrasonic inspection (NDE) methodology. In particular, areas of debonding between the rubber and fabric can be detected using reflectance methods. Samples must be immersed in oxygen-free water and coaxial transducers offer optimum results. References on this subject are provided in Appendix L.

7.6.3 Interpretation

All of the results from the above test methods should be considered in the context of the application and the environment. It would be wise to perform many of these tests on incoming diaphragms to have base-line data readily available in the event of a failure and to serve as a method for comparing different diaphragm materials and constructions prior to placing them in service. All numbers should not be considered absolute because the material properties will change with compound formulation, cure conditions, and degree of crosslinking. All crosslinking reactions are performed with an intended range of final values because precise control is nearly impossible to attain. A difference of a few percentage points in degree of cure is to be expected and should not be considered an indication of a defect or flaw.

Table 7-3 presents a summary of typical failure mechanisms and associated potential causative factors for typical AOV soft parts. This table has been prepared as a guide and is best used in conjunction with suitable references, such as those listed in Appendix L.

Table 7-3
Summary of Representative AOV Soft Parts Failure Mechanisms

Symptoms	Possible Causes
Excessive deformation at periphery	Over-clamping, excessive operating temperature, under-cured rubber, oil exposure, solvent exposure
Crazing at outer edge of diaphragm	Ambient solvent exposure, excessive ambient temperature, conventional thermal aging, inappropriate operating temperature, severe over-clamping
Embrittlement and "flaking" at periphery	Thermal degradation, solvent attack, radiation damage, extended aging
Wrinkling or lack of flatness	Improper original storage, improper molding, distorted installation, over-pressurization, adverse oil or solvent interaction
White surface deposit	Dried silicone grease, "blooming" of antioxidant from bulk rubber to surface
Yellowish, waxy surface deposit	Migration of processing waxes, acid, or other processing aid migration
"Twisted" appearance	Center bolt tightened improperly, transferring torque through diaphragm
"Ballooning" of diaphragm	Improper cure, extended high temperature operation, loss of fabric support
"Blisters" in rubber	Improper manufacture, solvent attack
Crazes on surface	Thermal damage, solvent attack, improper material for condition, aging
Circumferential tear along flange edge	Over-tightening, over-pressurization
Axial tear	Over-pressurization, improper fabric lay-up, improper clamping force at flange
Compression damage non-uniform along flange edge	Over-tightening of the bolts
Rust stains	Corrosion caused by chlorides from the rubber interacting with the housing, other corrosion sources such as moisture or chemicals
Rust particles	Can cause impingement into the rubber affecting leak tight seal
Eccentric bolt holes	Non-uniform clamping
Reduced pliability of rubber	Excessive operating temperature
Fabric visible from rubber layers	Poor alignment during molding (in some cases where uniform, this is by design)
Badly distorted center profile	Improper installation (upside down in actuator), improper cure, severe solvent or oil attack

7.7 POTENTIAL FAILURE MECHANISMS

There are a number of mechanisms by which AOV diaphragms can be degraded while in service. Many degradation processes are apparent by visual inspection of the affected components and by basic considerations of polymer properties and performance characteristics. Others may be more subtle, resulting from unusual environmental conditions, anomalous handling, or problems associated with the product or its processing. Many of the common failure mechanisms are synergistic and the worst case can result in a rupture of the diaphragm, rendering the valve inoperable. Table 7-3 provides a list of the most representative failure mechanisms and typical associated evidence.

Even if a diaphragm shows classical evidence of a particular form of degradation, at the very least, a visual examination should be conducted to ensure that other factors that might affect other diaphragms in service did not contribute to the failure. When a failed component is being examined, attention should not be focused only on the factors that caused the failure. Instead, having the opportunity to assess a failed diaphragm affords a parallel opportunity to examine for other degradation mechanisms.

7.7.1 Mechanical Rupture

Diaphragms are typically operated near their mechanical stress limit when pressurized, as currently designed. The stress distribution is complex and difficult to model precisely due to the asymmetric properties of the reinforcing fabric. As a result of the high stress condition, a tear or other significant defect tends to propagate in a non-arresting manner. Tears are typical of what constitutes a failed diaphragm. Other degraded conditions might not be apparent until a valve is dismantled, and then the evidence is discovered upon visual inspection. For example, a diaphragm that contains a crazed rubber surface still might perform well in service. Testing of an inservice valve might show some increased leakage under such conditions, but this would only be expected if crazing propagated through the entire thickness of the diaphragm.

Many ruptures are initiated because of damage associated with installation practices. The diaphragm shown in Figure 7-20 contains a significant rupture that extends along the flange edge. This tear has a radial component that extends toward the center of the diaphragm. A thorough investigation revealed that a number of types of degradation were present, but the primary cause of failure was linked to mechanical damage from over-torquing of the bolts. This over-stressed the internal reinforcing fabric, leading to the tear.

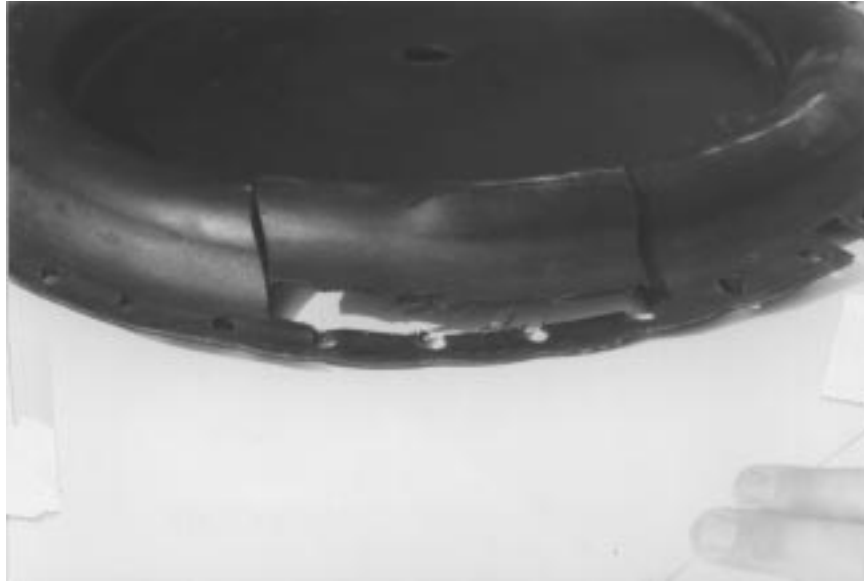

Figure 7-20
Photograph of a Failed Diaphragm with a Six-Inch Rupture

In some cases, manufacturing defects have been linked to the failures. To determine the root cause of a rupture, the fracture surface should be visually examined in detail. Much like fractographic examination with metals, the fracture surface of the rubber can be examined closely to determine the origin of the fracture, the direction of propagation by noting features such as striations and shear lips, and the approximate mechanisms by which it initiated and propagated. If the fracture surface has remained relatively non-disturbed, determining the origin of the rupture can lead to the discovery of a contaminant, defect, or other anomaly that lies at the root cause of the event. This can also give an indication if the rubber started tearing along the flange edge and bolt holes or closer to the center of the diaphragm. In some cases, a primary tear is followed by a secondary tear that occurs as the diaphragm releases and the spring pressure exerts an ever-increasing stress due to the reduction in the remaining intact diaphragm surface area.

The fiber tips of the reinforcing fabric are more difficult to inspect, but scanning electron microscopy (SEM) is invaluable for examination of the fiber ends to determine the mode in which the fibers failed. Figure 7-17 is a micrograph showing an example of nylon fibers that have failed due to a tensile overload. The ends are characteristically elongated and necked to a thinner diameter. The fracture surface is typically oriented on a 45° angle with respect to the fiber axis because this is the plane of maximum shear stress. Elongation of the fiber tips is a function of the type of reinforcing fabric and the extent to which it is pre-drawn. Unfortunately, variations from diaphragm to diaphragm have been considerable.

Reinforcing fabric is woven from fibers that have typically been pre-drawn to some extent, to limit their deformation under load. If not drawn, the diaphragm would plastically deform under load, leading to impeded stroke performance. The extent of prior drawing of the fibers affects their appearance under conditions of a tensile overload. In

virtually all cases, some elongation is expected, producing at least **limited** necking adjacent to the fracture surface. This is the case for fabrics made with nylon, rayon, and Dacron. For aramid-type materials (Nomex and Kevlar, for example), elongation is severely limited by the inherently low extension limit of these highly oriented polymers. In all cases, though, a fiber tensile overload produces a fracture surface with characteristics very similar to those shown in Figure 7-17.

Tensile overloads can result from a variety of conditions. In most cases, this is not a bulk problem, but a localized process that results from conditions where the stresses have been concentrated for any of a number of different reasons. The most likely of these are:

- Wrinkling of the fabric within the diaphragm, leading to non-uniform stress distribution
- Shear-induced separation of the fabric from within the diaphragm, especially along the flange edge, aligned with the bolt holes
- Biased alignment of the fabric during molding
- Excessive clamping pressure
- Over-pressurization of the AOV due, for example, to an air pressure regulator failure
- Localized weakness in the fabric due to a weaving defect
- Localized weakness in the fabric due to prior physical damage
- Incomplete coverage with fabric reinforcement

Figure 7-16 is an example of fibers that were cut prior to failure of the associated diaphragm. The ends exhibit a pattern of uniform lengths where they protrude from the diaphragm surface. These are free of fractographic detail and of uniform diameter along the length of the fiber and at the surface immediately below the free ends. It is evident that rubber has been molded over the cut ends suggesting that this damage was present before the molding process. A defect of this type is very unusual and difficult, if not impossible to detect using non-destructive methods. Analysis for this condition after the fact, though, is reliable. Damage of this type would result from improper trimming of the fabric during diaphragm component assembly.

Brittle fracture behavior can be expected under unusual aging conditions. Thermal aging, as discussed in Section 7.7.5, can lead to oxidation of the fabric under extreme circumstances. Oxidation greatly reduces the elongation limit and tensile strength of most polymers. As a result of such degradation, brittle behavior of the fibers could be anticipated. Fracture surfaces of embrittled fibers would exhibit no necking, planar fractures that are oriented transverse to the fiber axis, and a surface that exhibits glassy or nearly featureless surface details.

It is important to note that examination of the surfaces of only a few fibers could be misleading in a root cause analysis. For any given length of diaphragm fracture surface, there may be hundreds of torn fibers. It is imperative that the fracture origin be first

identified so that appropriate attention can be directed to determining how the fracture initiated. Inspection of a representative population of fibers in this area is essential.

7.7.2 Compression Damage

Some forms of degradation lead to non-catastrophic near-term damage, but over time the weakened diaphragm materials might propagate a rupture. Compression damage, for example, rarely renders the diaphragm non-functional, but it does place significant additional stresses on the fibers and tends to cause them to pull away from the rubber matrix and leave non-reinforced areas near the bolt holes and other critical surfaces, as shown in Figure 7-21.



Figure 7-21

Photograph of Exposed Fibers near a Bolt Hole Showing the Fiber Pull-Out

Cyclic loads can also contribute to the progressive failure of individual, highly stressed fibers in critical locations, especially when compressive loads are very high, resulting in reduced protection of the fabric. A significant reduction in thickness could also lead to leakage or difficulties with the fit of the flange edge. Figure 7-22 shows a diaphragm that has been significantly compressed during service. The edge of this diaphragm no longer has a continuous arc, forming instead a scalloped outer edge profile. The rubber has been extruded in the less constrained areas between the bolt holes.



Figure 7-22

Photograph of a Severely Compressed Diaphragm, Removed from Service after Failure

A view of the bolt holes on the same diaphragm is presented in Figure 7-23. The rubber has apparently been extruded out of the plane of the flange and into the bolt holes. This type of gross deformation is further quantified in Figure 7-24. This graph compares the radial thickness profile for a damaged diaphragm flange edge and a spare diaphragm of the same materials and vintage that has not been placed into service. The diaphragm has been compressed so severely that the raised rubber ridges that are used to guide the placement of the diaphragm in the housing are nearly indistinguishable and have been extruded away from their original location.

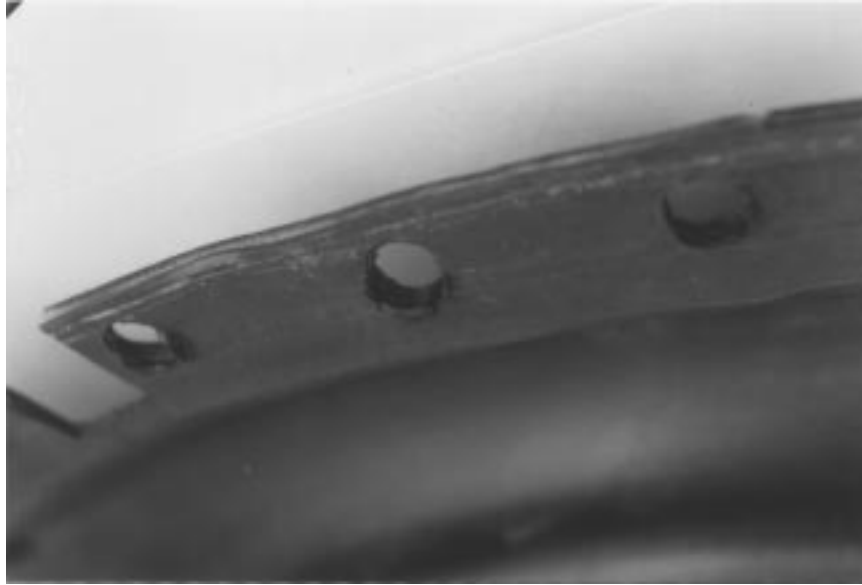

Figure 7-23
 Photograph of Bolt Holes on a Severely Compressed Diaphragm, Showing the Extrusion of Rubber between the Threads

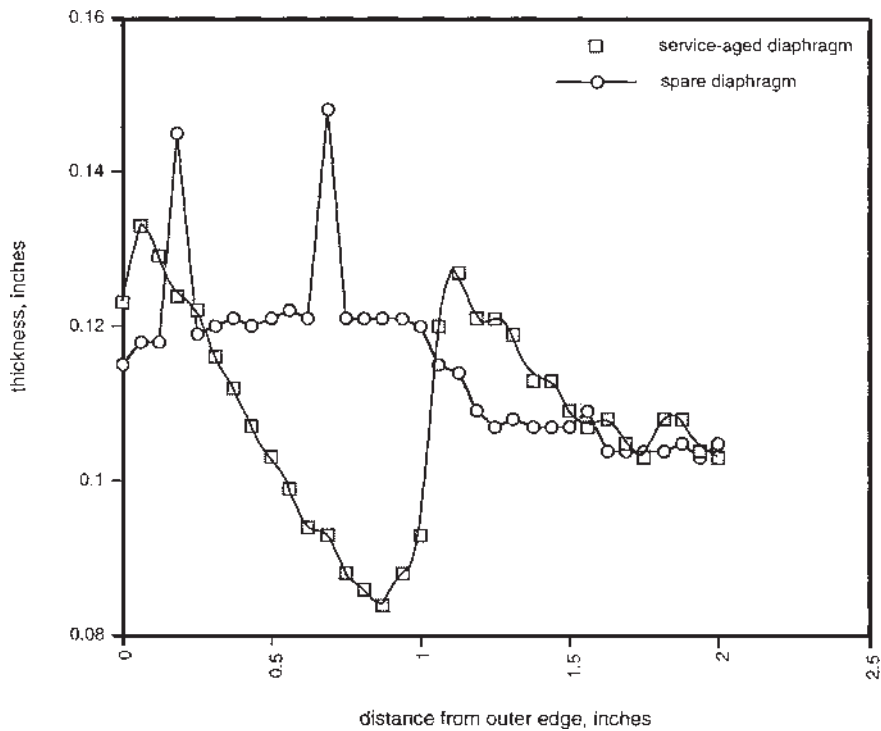

Figure 7-24
 Comparative Thickness Profile Measurements for a Diaphragm Removed from Service and a Non-Used Diaphragm

Excessive compression damage typically results from any of the following conditions or combinations thereof:

- Excessive clamping force during assembly
- Re-tightening of bolts to combat leaks
- Extended operation at elevated temperature
- Softening of elastomer due to oil or chemical exposure
- Softening of elastomer due to lubricant contact or solvent cleaning
- Improper curing of diaphragm material
- Housing bolts that have been changed with replacements containing reduced thread pitch; prior torque settings result in excessive clamping pressure
- Inappropriate housing bolt torque specifications applied
- Asymmetric tightening of housing bolts
- Use of incorrect torque scale

7.7.3 Solvent Exposure

Chemical degradation typically involves exposure of the rubber to an aggressive solvent. Solvents that can cause significant degradation of diaphragm materials need not “smell strong,” nor must they be flammable or particularly volatile to cause problems. Misconceptions abound, suggesting that exposure to any solvent or alcohol spells disaster, but this is clearly not the case. Solvent exposure causes significant harm if it chemically attacks the polymer and/or its additives and if it is absorbed within the polymer to a depth sufficient to cause bulk degradation. Some solvents and chemicals are particularly harmful to most types of rubber diaphragm materials. Table 7-4 is a listing of materials potentially hazardous to diaphragms that could be expected to be found in the plant environment. Listed with each are common sources of the corresponding material.

Questions of adverse chemical interactions for specific plant materials can be answered in part by consulting suitable references, as indicated in Appendix L. As previously noted, formulation details vary with the manufacturer, so it is recommended that tests be conducted on actual materials. A used or sacrificed spare diaphragm, cut into strips, is particularly well suited for the assessment of chemical or solvent interaction. Chemical attack is indicated with swelling and/or weight gain or loss. Exposure for 24 hours is recommended, and moderate temperature acceleration can be used to provide a near-term indication of potential adverse interactions.

It must be cautioned that thermal acceleration above 60°C could provide misleading indications, because the polymer structure changes at this level. It is also wise to pay attention to the specific flash point of many chemicals before heating them because many are quite volatile.

Table 7-4
Sources and Types of Plant Chemicals and Solvents Potentially Harmful to Diaphragm Elastomer Materials

Solvent/Chemical	Typical Sources
Methylene chloride	Paint stripper, degreasers
Acetone	Paints, paint strippers, cleaning materials
Denatured alcohol	Cleaning solvents
Xylene	Cleaning materials, plastic cements, adhesives
Methylethyl ketone (MEK)	Paint stripper
Toluene	Paint stripper, plastic cements, adhesives
Sodium hypochlorite ("chlorine")	Bleach, water antifoulant
Cyanoacrylate esters	Non-cured "Loctite" materials, "super glue," thread-locking materials
Light aromatic oils	Penetrating oils, "utility" spray lubricants
Hydrazine	Feedwater polishing
Ammonium hydroxide	Feedwater polishing
Stearic acid	Penetrating oils

Solvent attack of elastomers typically leaves a definitive "fingerprint," useful for forensic examination purposes. Following attack by an aggressive solvent, the rubber is dissolved, leaving behind a network of loosely bonded filler particles. This process is self-propagating because it creates additional surface area of exposed rubber to attack as shown in the SEM micrograph in Figure 7-13. The attacked areas are typically found within and along the edges of small, thin cracks known as crazes. The crazed areas are a network of linked cracks that form in the rubber and are most easily visible when the diaphragm is bent or flexed. In mild cases, it is difficult to see the crazes without flexing the diaphragm, while in others they are readily visible from the surface as shown in Figure 7-25. Crazes usually run perpendicular to the direction of maximum stresses; therefore, they typically run radially around the circumference of diaphragms in the event of solvent exposure and are most pronounced along the interior corner.

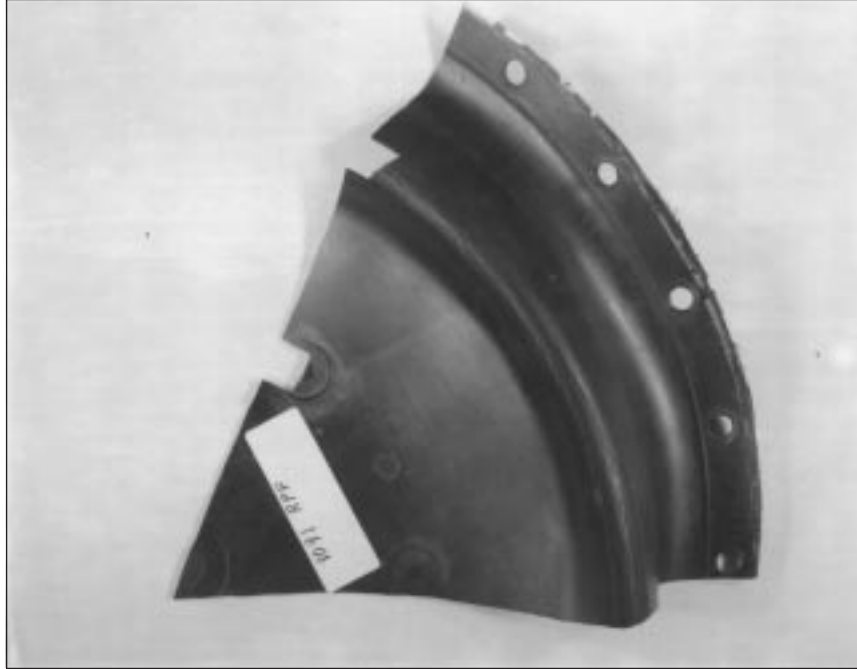

Figure 7-25
Photograph of Crazed Surface of a Section of an OV Diaphragm
Removed from Service during ISI

Solvent attack of the reinforcing fabric would not be expected following exposure to anything with the exception of sustained immersion in any solvent found in the plant environment. Due to the protection inherently provided by the over-molded rubber, such damage would be unlikely.

7.7.4 Lubricant Interaction

Lubricant interaction mechanisms will be discussed in detail in Section 7.8. Although lubricants are not recommended for use with AOV diaphragms, in some cases lubricants are used or inadvertently come into contact with AOV diaphragms due to migration from other components, spills, or other sources. Silicone lubricants have been inappropriately applied in some cases as an aging preventive treatment. Depending on the chemical formulation of the lubricant and rubber compound, swelling, crazing, embrittlement, dissolution, shrinking, and discoloration are all potential forms of damage that can occur. Environmental factors, such as temperature and mechanical stress, also affect the severity of lubricant interactions with the rubber. Reinforcement fabrics are immune to degradation caused by lubricants that would be found in plant environments.

7.7.5 Thermal Degradation

Polymeric components experience thermal degradation at much lower temperatures than most metals. Oxidation can take place at temperatures as low as 100°C for some

polymeric materials. The rubber portion of most diaphragms is designed to withstand temperatures up to 140°C and sometimes higher, but ambient temperatures in some areas of a power plant can be far greater than the oxidative stability of the part over prolonged periods. Oxidative stability is both time- and temperature-dependent. Therefore, periodic temperature excursions can sometimes be tolerated, but extended exposure eventually leads to degradation.

Figure 7-26 is an SEM micrograph of the surface of a diaphragm that bonded to the flange during service due to excessive thermal exposure. Other indications of thermal degradation are embrittlement and the formation of surface residues. Embrittlement severely reduces the flexibility and compression set resistance of the diaphragm. A surface film indicates that one of the components of the formulation, such as a low melting point processing aid like polyethylene wax, has migrated to the surface of the component. For AOV diaphragms, the surface film itself does not present any significant concerns, but its presence suggests that more serious problems will arise and the condition of the diaphragm should be evaluated.

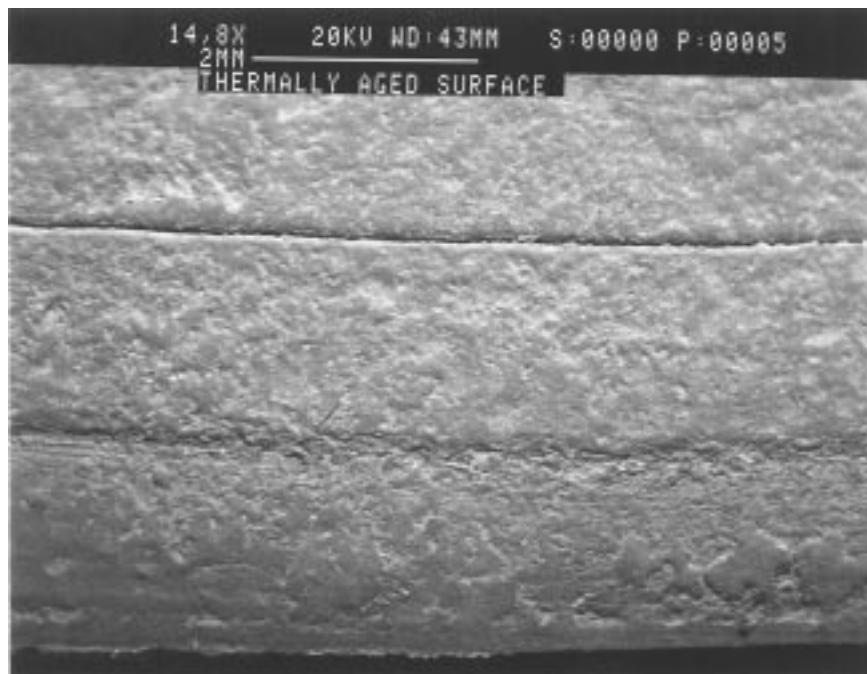

Figure 7-26

SEM Micrograph of a Diaphragm Surface Damaged by Thermal Degradation, Showing the Texture of the Flange Surface

In some cases, diaphragms have been noted to become sticky following service aging. Often, this is attributed to oil exposure. While this might be correct in limited cases, it should be verified by chemical extraction and appropriate chemical analysis so that its source can be identified and corrected. Most commonly used instrument air compressor oils do not cause diaphragm materials to become sticky. It is also unusual for oils to

survive through dryers, dehumidifiers, and the tortuous air line path leading from the compressor to the valves.

Thermal aging at temperatures well below the level necessary for oxidation can lead to diffusion of certain processing aids, internal lubricants, and plasticizing agents to the surface of the elastomer. When these migrate to the surface of the diaphragm, they concentrate at the surface, causing it to become over-plasticized. Typical examples of such plasticizing agents would include stearic acid, aromatic oils, phthalate esters, and montan wax. The scenario of surface plasticization is illustrated in Figure 7-27. In general, diaphragms should be formulated in the absence of processing aids that are subject to such migration, since elevated temperature exposure can be anticipated for many systems on which AOVs serve.

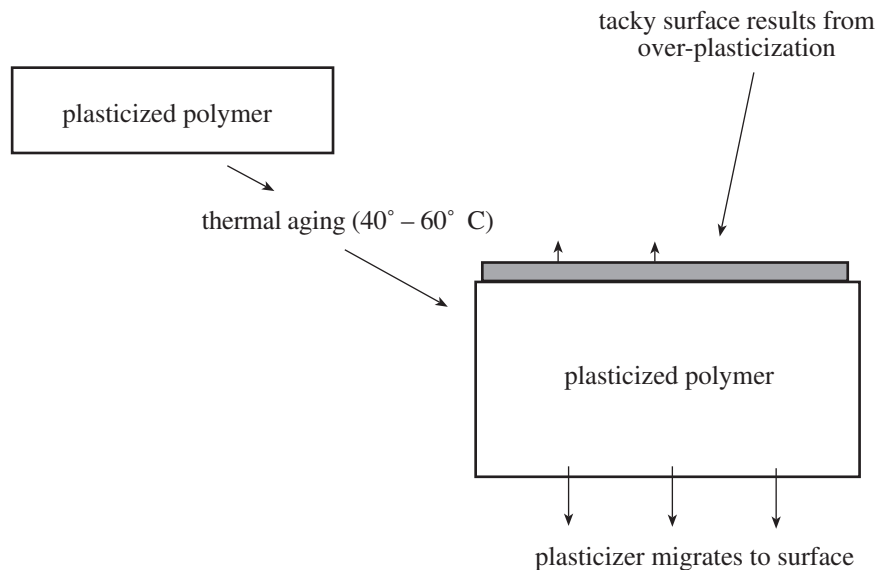

Figure 7-27

Illustration of Plasticizer Migration from within the Bulk Elastomer, Concentrating at the Surface Following Thermal Aging

Thermal damage to the reinforcing fabric is rare because the materials generally used are more thermally tolerant than the overlying elastomer. One exception, under unusual circumstances, applies to nylon. Nylon normally absorbs approximately 4 weight percent of water. This acts as an internal lubricant, effectively plasticizing the polymer. In the absence of this moisture, nylon becomes embrittled. This is one reason that nylon is not relied on for impact-resistant components in refrigerators or vacuum systems. In the case of a diaphragm application, moisture loss is limited by the overlying rubber and also by the inherent moisture found in storage conditions and in valve air systems. At elevated temperature, combined with very dry conditions, embrittlement could be expected following very long service intervals. All other current reinforcement materials are immune to this process.

7.7.6 Delamination

Delamination of the rubber and fiber layers is usually the result of a combination of factors. The fibers can be separated from the rubber matrix through a mechanical disruption, such as drilling bolt holes instead of punching, as shown in Figure 7-12. The rubber also separates from the fibers if it has been significantly chemically altered. If the rubber is embrittled due to thermal exposure, for instance, it might pull away from the fibers if it is flexed during valve actuation. This is the result of mechanical stress concentration at the interface caused by the reduced modulus of the embrittled elastomer. Shrinkage of the rubber because of some types of lubricant exposure can have a similar effect.

The most common cause of delamination is improper molding of the diaphragm. An effective mechanical/chemical bond is achieved when the elastomer is caused to flow into and permeate the fabric weave. Eventually, the elastomer from either face of the diaphragm should permeate through the fabric, forming a fully bonded structure. This requires that the molding pressure be applied in a consistent manner, early in the molding process before the elastomer begins to crosslink (cure). Once cured, the elastomer cannot be caused to flow into the fabric. Failure to achieve adequate bonding can result in delamination in service. Other causes of delamination include contamination of the fabric, exposure of the fabric to mold release agents (such as silicone oil), excess moisture on the fabric, and cycling of diaphragms under extremely cold conditions.

7.8 LUBRICANT INTERACTION WITH POLYMERIC COMPONENTS

This topic has been briefly addressed in previous sections, but will receive a more in-depth treatment because of the recent concerns with lubricant interactions. Few lubricants are used in conjunction with AOV diaphragms, but O-rings, gaskets, and seals are frequently exposed to lubricants in service. Although some lubricants are applied to elastomeric components by design, others come in contact with elastomers through spills, leaks, inappropriate application during assembly, or other inadvertent contact. The air stream flowing through AOVs and vapors from materials on neighboring components can also result in contact, although this would be an unusual condition.

Lubricants that intentionally come into contact with elastomeric components are typically used for sliding contacts, for adhesion prevention in clamped parts or pressure vessel applications, or as a sealing aid. They are sometimes used as barrier coatings for applications such as chemical processing equipment and tracking prevention on electrical components. Lubricants are thought to offer a simple way to promote lifetime extension of parts by reducing friction and wear on metallic components, but their effect is often the opposite for many elastomers.

Much like the generic treatment of base resins for compound systems discussed in Section 7.1, many lubricants are known by generic names such as silicones, lithium grease, hydrocarbon grease, and others. These names actually represent a large family of available products with very different chemical structures. Silicone greases, for example, consist of methyl-, phenyl-, or phenyl methyl-silicone oil, thickened by the addition of silicon

dioxide powder. Because the elastomers themselves represent a variety of formulations as well, it is difficult to generalize their response to lubricant exposure. To the extent possible, this section briefly reviews common lubricant formulations, their interaction with representative elastomers, and suggestions on lubricant selection.

7.8.1 Common Lubricants in Plant Applications

A wide variety of lubricants is widely used in power plants. They are provided as liquids, pastes/gels, sticks, sprays, and dry powders. The most common lubricants are a number of hydrocarbon grease formulations. These products are made with natural, synthetic, or complex hydrocarbons, depending on the required function and temperature stability. Some are supplied with metallic soaps, based in lithium or molybdenum. Hydrocarbon oils are also from the same basic family and can be purchased in natural, synthetic, and complex forms as well. Many other lubricants are provided as suspensions, such as graphite in oil or water, molybdenum disulfide in mineral oil, or organics suspended in light synthetic oils. Dry lubricants are often supplied in an alcohol suspension to aid with dispersion and application. These typically consist of microparticulate Teflon or other fluoropolymers that form a temporary lubricating film.

7.8.2 Degradation Mechanisms

Adverse effects of polymer/lubricant interactions are manifested in varying degrees of severity. In some cases, some damage is induced through limited swelling, increased tackiness, and reduced static and dynamic friction. These forms of degradation impair the performance of the polymer to a small degree, but in most cases do not cause immediate loss of functionality. Moderate damage, such as significant swelling, increased tackiness, decreased recovery, and plastic deformation, can also be present after prolonged interaction or in the case of a more incompatible combination of materials. In extreme cases, shrinkage of the part, gross plastic deformation, crazing, discoloration, and dissolution can result. Significant damage of this nature results in a loss of function of the seal, diaphragm, or other component in nearly all cases. An elastomer in this condition often bonds to adjacent surfaces, ruptures, breaks, and/or loses its sealing capabilities altogether. There are a number of mechanisms by which lubricants can degrade polymers. These are dependent on the formulation of both materials and, in some cases, can be aggravated by the service environment.

Solvolysis refers to the dissolution of the non-crosslinked portion of the polymer. In this case, some component of the lubricant formulation would act as the solvent. This typically leads to the shrinkage of the elastomeric component, increased stiffness, cracking, and decreased elastic recovery. These detrimental characteristics are provided by the presence of the rubbery non-crosslinked polymer that is compromised by dissolution in the solvent.

Some lubricants are absorbed by the polymer, causing the component to swell. This often results in decreased hardness, reduced modulus of elasticity, and reduced tensile strength. Spontaneous compression fractures can also result because the polymer has been expanded by the swelling. In most cases, this change is permanent, and although

some lubricant remains on the surface of the part, the amount contained within the bulk of the elastomer does not significantly dissipate over time.

In some cases, after the lubricant has been absorbed by the polymer, it serves as an internal lubricant to the component. This causes limited swelling, but often leads to decreased modulus of elasticity and tensile strength. Increased surface tack can also cause the affected component to stick to adjacent surfaces. In some cases, the internal lubricant can actually increase the life of the component depending on the application. Internal lubricants, such as stearic acid or zinc stearate, are used to aid the processability of elastomeric components.

From a given compound, a particular lubricant might attack only one ingredient in the formulation. This is referred to as selective extraction. The antioxidant, processing waxes, plasticizer, or other additive from a formulation can be selectively removed, leaving behind all other materials. Depending on what types of additives were removed, the damage from this process ranges from inconsequential to devastating. In most cases, this results in embrittlement of the part and causes a loss of resistance to permanent set and decreased overall modulus.

Many lubricants are compounded materials. Various chemical additives that were used to give the lubricant a certain property such as temperature stability, penetration capability, decreased surface tension, or other physical properties, can deteriorate elastomeric components on contact. Penetrating lubricants, which are frequently in the form of organic acids combined with light oils, oxidize and/or dissolve many elastomers. Chlorinated hydrocarbon greases could soften many polymers while aliphatic esters, which are used as thread sealants, can plasticize some components.

7.8.3 Polymer/Lubricant Compatibility Screening Tests

Rather than take a risk, especially for a widely used component, a quick screening test for compatibility is recommended to reduce the possibility that surrounding lubricants will degrade a diaphragm, seal, or other component. To prepare a sample for this test, two sections of the elastomer should be removed. These should be pieces from the actual component, because a “representative” piece of Neoprene or other polymer from another application might not have the same compound formulation. Even if a “Viton” seal from one supplier appears to be highly compatible with a certain silicone lubricant, seals from a new supplier should also be tested due to potential formulation differences. Testing might not be practical or necessary for every soft part in the plant, but for areas where problems have been noted or for critical applications, this could prove quite useful in determining corrective actions or outlining recommended installation and maintenance procedures.

When a sample has been selected, the elastomer surface should be cleaned with a dry, clean cloth that has not been used with cleaning solvents or other chemical substances.

One sample should be maintained as a reference that is subjected to the same environmental conditions but is not exposed to any lubricants. Place some lubricant on the second sample of the elastomer and heat both samples for as long as possible at 60°C, depending on how much time is available. If the component's service environment is exceptionally hot, it is recommended that the samples be tested at the expected service temperature. Examine the sample surface for indications of interaction with the lubricant. If the lubricant obscures the sample surface, wipe it clean with a dry cloth.

Different responses to the lubricant can provide clues to the nature of any adverse interactions that are observed. This information can be used in the appropriate selection of alternate lubricants if the first proves unacceptable. Swelling indicates lubricant absorption. Color changes and crazing suggest chemical interaction, but only a surface change, such as the presence of a residue, would suggest selective extraction of only one component of the formulation. A color change in the lubricant also suggests chemical interaction or extraction. Blistering or wrinkling of the polymer surface suggests an aggressive solvent attack.

It is also possible to independently evaluate the generic response of lubricants to different environmental conditions to determine the applications for which they would be best suited. Start by reading the labels to note any manufacturer's warnings or recommendations. If they put it in print, it is probably a serious concern. Warnings about flammability for systems that use a propellant to facilitate a spray should be considered in all situations. Direct contact with the manufacturer can often yield significant engineering application and performance data.

The person conducting the test should remove a small sample of the lubricant from its packaging and rub it between their fingers. Strong odors indicate that volatiles are present. In many cases, this is an indication that the lubricant will not offer long-term stability. If the fingers feel slippery after removal of the lubricant, this is consistent with many silicones. A gritty-feeling lubricant should not be used for sealing applications because the small particles create a leak path in most situations.

Other tests can be performed using any oven that has a reasonably low operating range. Place a small amount of the lubricant on a piece of filter paper to monitor the "bleed." This can first be performed at room temperature and then checked at a slightly elevated temperature around 60°C. If the lubricant separates or "bleeds" and creates a stain around itself, this shows a phase separation of the materials present. This could indicate a potential for migration of the lubricant in service and inconsistent performance over time. To determine a lubricant's properties for an elevated temperature application, a measured weight of the lubricant can also be placed in a glass dish of a known weight and placed in an oven. The weight loss versus time and temperature can be monitored to determine if the lubricant offers sufficient stability between regular maintenance for the component. The temperature of the intended environment can be used as the basis for this test, with an increase of 10°C to accelerate the process.

7.8.4 Physical Considerations

Some lubricants consist of solid lubricating particles, suspended in a light oil, solvent, or water, for example, graphite lubricants, which are formulated with a dispersant and solid, milled graphite particles. In Figure 7-28, the surface of a diaphragm is shown after exposure to a popular graphite type of lubricant. It can be seen in this view that the sealing surface would be “bridged” by the high population density of graphite particles, thus compromising the sealing function. All dry and particulate lubricants should be avoided in contact with elastomers for sealing applications.



Figure 7-28
View of Graphite-Type Lubricant Film on the Surface of an
AOV Diaphragm after Drying

7.8.5 Recommendations

Establish a preferred list of simple lubricants that have been tested by plant personnel or trusted sources. For example, choose one high purity hydrocarbon grease, silicone oil, polyvinyl alcohol, stable silicone grease, and non-solvent silicone spray. During selection, pay careful attention to the material safety data sheets (MSDS) to look for any warning signs of instability or unwanted product additives. Try to avoid general purpose spray lubricants because many of these are not only dangerous to polymers but are also flammable. For some sealing applications, try a more highly plasticized rubber component or an elastomeric gasket sealant, instead of greases.

APPENDIX A

GLOSSARY

actuator. A device that changes the flow through a control valve in response to a pneumatic or electronic input signal.

actuator, pneumatic piston. An actuator with a piston and cylinder assembly in which the movement of the piston is controlled by changes in air pressure. Pneumatic piston actuators are divided into three types of construction: *double-acting* (springless) has the loading pressure connection ports at the top and bottom of the cylinder; *spring-bias* (spring) is essentially a double-acting actuator with a spring added; *spring-return* (spring) has an internal spring but only one loading pressure connection port.

actuator, spring and diaphragm. A pneumatically operated compressible fluid- (usually air) powered device in which the fluid acts upon a flexible member, the diaphragm, to provide linear motion to the actuator stem.

actuator force. The amount (pounds) of force that a sliding stem actuator is capable of applying to the positioning of an end use component.

actuator lever. A lever used with rotary shaft valves to convert linear motion (thrust) into rotary motion (torque).

actuator response. The speed or accuracy with which an actuator responds to an input signal.

actuator stem. In sliding stem valves, an extension of the piston rod that permits convenient connection to the valve stem.

actuator torque. The foot-pounds of torque that a rotary actuator is capable of applying to the positioning of an end use component. It is usually discussed in terms of *breakout torque*, (overcoming internal valve friction, and seating or unseating a valve's closure member) and *dynamic torque*, (the throttling of a rotary valve).

actuator/valve stability. A measurement of an actuator's ability to maintain the closure member in a given position.

amplifier. A component that allows an input signal to control a power source that is independent of the signal.

ball, full. The flow-controlling member of a rotary shaft control valve that consists of a sphere with a flow passage through it.

ball, v-notch. The flow-controlling member for a popular style of throttling ball valve. The V-notch ball includes a polished or plated partial-sphere surface that rotates against the seal ring throughout the travel range. The V-shaped notch in the ball permits wide rangeability.

beam. The summing point of a control valve positioner.

bellows. A flexible cylinder that expands or contracts to convert pressure to force or motion. Often used in positioners to position the beam.

bench set. A specification that is used to verify proper actuator operation. Bench set is expressed as the pressure range from the start of the actuator stroke to the valve's rated travel.

block valve. An isolating valve, often a butterfly valve, used to create a bypass around the control valve. A bypass is frequently created so that service can be performed on the control valve without shutting down the process.

Bode plot. A plotting technique in which dynamic attenuation and phase shift of an element are shown as a function of frequency.

bonnet. A pressure-retaining component that can guide the stem and contain the packing box and seal.

bonnet assembly. An assembly including the part through which a valve plug stem moves and provides a means for sealing against leakage along the stem. It usually provides a means for mounting the actuator.

breakout torque. The portion of the total operating torque that is attributable to friction in the packing and bushings, and between the valve closure member and the seal.

cage. A hollow cylindrical trim element that guides the movement of a valve plug. The cage can also retain the seat ring in the valve body. The walls of the cage have openings that determine the flow characteristic of the control valve.

cage-guided valve. A type of valve that uses a cage for plug guiding and alignment.

calibration. The act of adjusting the output of a device so that it corresponds to the value of the input of the device. In positioner calibration, zero, span, and crossover (balance) pressure are the primary calibration adjustments.

capacity. The rate of flow through a valve under stated conditions.

cavitation. In liquid service, the noisy and potentially damaging phenomenon that accompanies bubble formation and collapse in the flowstream.

closed loop control. Pertaining to a system with a feedback type of control, such that the output is used to modify the input.

closure member. A moveable part of a valve that is positioned in the flow path to modify the rate of flow through the valve.

control valve. A power-operated device that modulates the fluid flow rate in a process control system. It consists of a valve connected to an actuator mechanism that is capable of changing the position of a flow-controlling element in the valve in response to a signal from the controlling system.

controller. A device that operates automatically to regulate a controlled variable.

corrosion. The damaging effects of hostile media on control valve components resulting from material incompatibility.

cross head. The component joining the actuator shaft to the valve stem.

deadband. The range through which input can be varied without initiating an observable response.

diaphragm. A flexible member capable of producing an output in force or motion in response to a pneumatic input signal.

direct-acting actuator. An actuator in which the actuator stem extends toward the control valve in response to an increasing input signal.

direct-acting positioner. A positioner that provides increasing output pressure in response to an increasing input signal.

double-acting positioner. A positioner that has two relays, typically used with double-acting and spring-bias actuator designs.

disk, balanced. A butterfly valve disk contoured to balance flowing fluid forces and pressures along the disk surface during use. This design reduces actuator torque requirements during throttling.

disk, conventional. The flow-controlling member used in the most common varieties of butterfly rotary valves. High dynamic torques normally limit conventional disks to 60-70 degrees maximum rotation in throttling service.

disk, eccentric. Commonly referred to as a high performance butterfly valve (HPBV). See high performance butterfly valve.

dynamic attenuation. The reduction of gain that results from the inability of a device to respond to inputs of increasing frequency. A decrease in signal between two frequencies.

dynamic response. The response characteristics of an element, including phase shift and dynamic attenuation, observed as the frequency of the input is varied.

dynamic torque. The torque produced in quarter-turn valves as a result of the forces produced by mass flow.

elastomer. A rubber-like synthetic polymer, such as silicone rubber. The broad term for gaskets O-rings, diaphragms, and some packing.

erosion. The damaging effects of gritty or dirty fluids on control valve components. Erosion is forestalled with hardened materials and with valve designs that separate the flowstream from critical valve components.

equal percentage characteristic. The inherent flow characteristic which for equal increments of rated travel, will give equal percentage changes of the flow coefficient C_v .

extension bonnet. A bonnet with a greater distance between the packing box and bonnet flange for hot or cold service.

fail-closed (FC). A condition in which the valve port remains closed in the event of loss of supply pressure. See failure, fail mode, and fail open.

fail, mode. The position to which a valve returns on the loss of supply pressure. For example, in spring-return and spring-bias actuators, the springs permit fail-open or fail-closed operation.

fail-open (FO). A condition in which the valve port remains open in the event of the loss of supply pressure.

failure. A condition in which the actuator or position fails to operate through the loss of supply pressure.

flangeless body. A body style common to rotary-shaft control valves. Flangeless bodies are held between ANSI, DIN, JIS, and other types of class flanges by through bolts. (Sometimes also called wafer-style valve bodies.)

flashing. A phenomenon observed in liquid service when the pressure of the media falls below its vapor pressure and does not recover to a higher pressure.

flow characteristic. The relationship between the flow through a valve and the percent rated travel as the latter is varied from 0 to 100%. This is a special term. It should always be designated as either inherent flow characteristic or installed flow characteristic. Common flow characteristics are linear, equal percentage, and quick opening. See inherent flow characteristic and installed flow characteristic.

flow coefficient, fluid (C_v). The number of U.S. gallons per minute of 60°F water that will flow through an orifice with a one pound per square inch (psi) pressure drop.

flow ring. A heavy-duty ring used in place of a ball seal ring for V-notch and full ball rotary valves in severe service applications where some leakage can be tolerated.

gain. The ratio of the change in an output to the change in an input.

globe valve. A valve style with a linear motion flow-controlling member with one or more ports, distinguished by a globe-shaped cavity around the port region. Two types of plug guiding are recognized: cage guided and stem or plug guided.

guide bushing. A bushing in a bonnet, bottom flange, or body to guide the movement of a valve plug.

hard facing. The process of applying a material that is harder than the surface to which it is applied. This technique is used to resist fluid erosion and/or to reduce the chance of galling between moving parts, particularly at high temperature.

hardness. The resistance of a metal or other material to indentation, scratching, abrasion, or cutting. Metallic material hardness is commonly expressed by either a Brinell number or a Rockwell number. (In either case, the higher the number, the harder the material. For example, a material with a Rockwell "C" hardness of 60 is fairly hard while one with a hardness of 20 is fairly soft. Elastomer hardness is determined by a durometer test.)

high performance butterfly valve (HPBV). The common name for a valve design in which the positioning of the valve shaft-to-disk connections causes the disk to take a slightly eccentric path on opening. (This allows the disk to be swung out of contact with the seal as soon as it is opened, thereby reducing friction and wear.) See disk, eccentric.

high recovery valve. A valve design that dissipates relatively little flow stream energy due to streamlined internal contours and minimal flow turbulence. Therefore, pressure downstream of the valve vena contracta recovers to a pressure significantly higher than the pressure at the vena contracta. (Straight through flow valves, such as rotary-shaft ball and butterfly valves, are typically high-recovery valves.)

inherent flow characteristic. The flow characteristic when constant pressure drop is maintained across a valve.

inlet. The body opening through which fluid enters a valve.

input. A particular process quantity or variable that has been identified to be the cause of subsequent changes in the values or actions of other process values defined as outputs.

input signal. A pneumatic or electronic signal sent to a control valve.

installed flow characteristic. The flow characteristic when pressure drop across a valve varies by the flow and related conditions in the system in which the valve is installed.

I/P converter. A transducer that uses current for an input and pressure for an output. See transducer.

isolating valve. A hand-operated valve between the packing lubricator and the packing box to shut off the fluid pressure from the lubricator.

leakage. Pneumatic pressure losses in either the actuator or positioner resulting from defective seals, O-rings, or gaskets; also fluid passing through a valve when the valve is in a fully closed position under stated closure forces.

leakage, seat. Fluid passing through an assembled valve when the valve is in the fully closed position under stated closure forces, with pressure differential and pressure as specified.

limit cycle. A non-linear control loop instability. Can be caused by friction-related deadband in the control valve.

linear action stem. The spring and diaphragm actuators designed for linear action valves produce linear force and motion. The actuator stem is connected to the valve stem by a suitable stem connector, without linkage or levers so there is no loss motion or dead band. The travel indicator pointer is attached to the actuator stem and the travel indicator scale is attached to the side of the yoke. Relative position of these two components indicate stem position.

linear characteristic. For control valves, a characteristic that produces a percentage of maximum C_v that is directly proportional to valve stem position as a percentage of full travel.

linear flow characteristic. An inherent flow characteristic that can be represented ideally by a straight line on a rectangular plot of flow versus percent rated travel. (Equal increments of travel yield equal increments of flow at a constant pressure drop.)

linear process. A process in which gain is constant, regardless of load.

low recovery valve. A design that dissipates considerable flowstream energy due to turbulence created by contours of the flowpath; consequently, downstream pressure recovery is reduced when compared to high recovery valves. (Although individual designs vary, conventional globe-style valves generally have low pressure recovery capability.)

maintenance. All activities performed on equipment in order to maintain or restore its operational function (corrective or preventive)

maintenance, condition directed preventive. Actions initiated as a result of equipment condition. Assessment and comparison with defined acceptance criteria. Surveillance tasks, such as inservice inspection (ISI), scheduled monitoring and trending, coupled with diagnostics are also included in this group of maintenance actions.

maintenance, corrective. Activities (diagnose and repair) performed to restore the functional capabilities of failed equipment.

maintenance, periodic preventive. Scheduled activities performed on equipment to reduce the probability of failure. Initiated by periodicities regardless of condition.

maintenance, predictive. Activities performed to assess the status of equipment or system degradation by the correlation of one or more parameters.

maintenance, preventive. All activities performed on equipment to avoid or reduce the probability of failure.

manipulated variable. The process input (quantity, property, or condition) that is adjusted to maintain the controlled variable at a desired setpoint.

measured variable. The physical quantity, property, or condition that is to be measured, for example, temperature, pressure, flow, level, speed, weight, and so on.

movement arm. In a rotary shaft actuator, the effective length of the actuator lever at a given point of actuator shaft travel.

mounting. The physical connection of an actuator to a control valve stem or shaft.

non-linear process. A process in which gain changes at different loads or flow conditions.

normally closed control valve (NC). A valve that closes when actuator pressure is reduced to atmospheric pressure.

normally open control valve (NO). A valve that opens when actuator pressure is reduced to atmospheric pressure.

nozzle-flapper amplifier. A pneumatic signal amplifier in which changing the position of the flapper relative to the nozzle results in changes in an output pressure.

outlet. The body opening through which fluid exits a valve.

output. A particular process quantity or variable that has been identified to be the result of the values or actions of one or more other process values defined as input.

packing. Plastic, elastomer, graphite, or other material used to seal valve shafts and stems.

packing box assembly. A cavity in the valve body used to seal against leakage around the valve plug stem or shaft. Included in the complete packing box assembly are various combinations of some or all of the following component parts: packing, packing follower, packing nut, lantern ring, packing spring, packing flange, packing flange

studs or bolts, packing flange nuts, packing ring, packing wiper ring, and felt wiper ring.

packing box or bore. A cavity in the valve body used to hold and locate packing rings.

packing lubricator. An optional part used to inject lubricant into the packing box.

phase shift. For a device, the amount of time that an output lags behind an input.

piston. A disk or short cylinder closely fitted in a hollow cylinder and moved back and forth by the pressure of a fluid or gas so as to transmit motion and pressure to the rod.

plug. The closure member of a globe-style control valve.

plug, eccentric. The flow-controlling member of an eccentric rotary plug valve. Because of its eccentric action, it clears its seat soon after opening.

pneumatic. Pertaining to or operated by air or other gas.

port. A fixed opening, normally the inside diameter of a seat ring, through which fluid passes.

positioner. A device that compares the actual actuator position with the desired position with respect to an input signal and adjusts actuator loading pressure until the desired position is attained. The desired position has a predetermined relationship to the input signal.

pressure drop. The difference between upstream pressure and downstream pressure that represents the amount of flowstream energy that the control valve must be able to withstand.

pressure drop, maximum allowable. The maximum flowing or shutoff pressure drop that a control valve can withstand. While maximum inlet pressure is commonly dictated by the valve body, the maximum allowable pressure drop is generally limited by the internal controlling components (liner, disk, shaft, bearings, seals). The maximum allowable pressure drop may apply to the pressure drop while flowing process fluids are at shutoff.

process gain (static). The ratio of the magnitude of change in the process variable to the magnitude of the change in input.

push down to close construction (PDTC). A valve construction in which the valve plug is located between the actuator and the seat ring, so that an extension of the actuator stem moves the valve plug toward the seat ring, closing the valve.

push down to open construction (PDTO). A valve construction in which the seat ring is located between the actuator and the valve plug, so that an extension of the actuator stem moves the valve plug away from the seat ring, opening the valve.

quick-opening. A characteristic that, for equal changes in stem position, provides a large change in C_v at low lifts and smaller changes in C_v at high lifts.

quick opening flow characteristic. An inherent flow characteristic in which there is maximum flow with minimum travel.

rangeability. The ratio of maximum to minimum flow within which the deviation from the specified inherent flow characteristic does not exceed some stated limit.

Rangeability is expressed as the ratio of the maximum flow coefficient to the minimum usable flow coefficient of a control valve.

rated C_v . The value of C_v at the rated full-open position.

recovery. A relative term used to describe how much flowstream pressure is reduced due to the design of the control valve; the ratio of maximum (valve fully open) downstream pressure to upstream pressure. See high recovery valve and low recovery valve.

regulator, air. Regulates supply air pressure to a preset value.

relay, pneumatic. A pneumatic power amplifier in which changes in input pressure result in changes in the position of exhaust and supply valves that control a separate supply pressure.

reliability centered maintenance. A maintenance plan based on identifying equipment or systems that have functional failures. The plan uses the failure population to develop or revise preventive maintenance programs.

retaining ring. A split ring that is used to retain a separable flange on a valve body.

reverse-acting actuator. An actuator construction in which the actuator stem retracts away from the control valve with increasing diaphragm pressure.

rod, actuator. Transmits force from the piston cylinder to the actuator lever in actuators used with rotary shaft control valves.

rotary-shaft control valve. A valve style in which the flow closure member (full ball, partial ball, or disk) is rotated in the flow stream to modify the amount of fluid passing through the valve.

saturation. The point in an operating range at which a change in input no longer causes an output change.

seat. That portion of the seat ring or valve body that a valve plug contacts for closure.

seat load. The contact force between the seat and the valve disk, ball, or plug. (In practice, the selection of an actuator for a given control valve is based on how much force is required to overcome static and dynamic unbalance with an allowance made for seat load.)

seat ring. A piece inserted in a valve body to form a valve body port. It is a seating surface for the closure member.

separable flange. A flange that fits over a valve body flow connection. It is held in place by means of a retaining ring. When conditions dictate the use of expensive alloys for valve bodies, these flanges can be manufactured from less costly materials.

setpoint. The desired value for the controlled variable. The setpoint is an input variable that can be manually or automatically set and is expressed in the same units as the controlled variable, for example, degrees F, standard cubic feet/hour (SCFH), psig. etc.

shaft. The portion of a rotary-shaft control valve assembly corresponding to the valve stem of a globe valve. Rotation of the shaft positions the disk or ball in the flowstream and, thereby, controls the amount of liquid that can pass through the valve.

shim seals. Thin, flat, circular metal gaskets used in varying numbers to adjust seal deflection in some ball valves. Increasing the number of shim seals used reduces the amount of seal deflection; reducing the number of shim seals used increases the amount of seal deflection.

single-acting positioner. A positioner with only one relay, typically used with spring-return actuator designs.

sliding stem control valve. A valve construction style in which the valve closure member (plug) moves in a linear path.

span adjustment. The calibration procedure that establishes the control valve position desired when the input signal is at the maximum value of the input signal range.

split range. A technique in which one controller is used to operate to final control elements.

static gain. The ratio of change of steady-state output to a change in input.

static open loop gain. The static gain of an entire system, measured by opening the loop and determining the ratio of the change in output to a change in input. Determined by multiplying the gains of all system elements.

static unbalance. The net force produced on the valve disk in its closed position by the fluid pressure acting upon it.

stem. See valve plug stem.

stem- or post-guided valve. A valve in which the plug is guided by a bushing that surrounds the stem or post (as opposed to cage-guided valves).

stem unbalance. The net force produced on the valve plug stem in any position by the fluid pressure acting upon it.

stiffness. The resistance of the actuator to forces that tend to destabilize its position.

stroking time. The time it takes an actuator to be moved between two predetermined positions (generally valve-open or valve-closed).

summing point. Any point at which signals are added algebraically. In a control valve positioner, summing is usually accomplished with a beam.

throttling. The action of a control valve in motion as it modulates flow.

torque. The tendency of a force to produce rotation about an axis.

transducer. A device that accepts an input in one form (pressure, electrical current, etc.) and provides a corresponding output in another form.

travel. The movement required to take a valve plug from the closed to the rated full-open position.

travel indicator. A pointer attached to a stem connector to indicate travel of the valve plug.

travel, rated. The amount of linear movement of the valve plug from the closed position to the rated full open position. (The rated full open position is the maximum opening recommended by the manufacturer.)

travel stops. Mechanical obstructions devised to limit actuator stem or lever travel in a specified direction.

trim. The internal parts of a valve that are in flowing contact with the controlled fluid.

trim, balanced. Trim that uses some design technique to minimize pressure unbalance across the valve plug. This technique reduces the actuator force that is necessary to throttle and seat the plug.

trim, noise abatement. Trim that is specifically designed to eliminate or reduce control valve noise due to the turbulence associated with high velocity flow.

trim, reduced capacity. A valve trim package that provides a smaller-than-standard port diameter to reduce capacity of the valve. Often used in startup situations when increased capacity at a later date is anticipated.

trim, soft seated. Globe valve trim with an elastomer or other deformable material used as an insert, either in the valve plug or seat ring, to provide tight shutoff with minimal actuator force.

trim, very low flow. A valve trim package that uses small special formed plugs that seat conventionally with a short stroke or fluted or splined plugs that protrude through the seat ring when accurate control at very low flow rates is required.

unbalanced forces. The force or torque produced when process pressure creates more force on one side of a flow-controlling element than on the other.

valve body. A housing for internal parts that have inlet and outlet flow connections.

valve body assembly (commonly *valve body*). An assembly of a body, packing follower (if used), and trim elements. The trim includes the valve disk or ball that opens, closes, or partially obstructs the ports.

valve plug. A movable part that provides a variable restriction of a port.

valve plug stem. The rod or shaft that connects the actuator to the plug.

vapor pressure. The pressure at which a given liquid begins to vaporize.

vena contracta. The location where the cross-sectional area of the flowstream is at its minimum. The vena contracta normally occurs just downstream of the actual physical restriction in a control valve.

wafer-style valve body. A flangeless type of butterfly or gate, short face-to-face, valve body. Also called a flangeless valve body; it is clamped between pipeline flanges.

zero adjustment. The calibration procedure performed to establish the desired valve position when the input signal is at the minimum value of the input signal range.

APPENDIX B

TEST CONNECTIONS FOR DATA ACQUISITION EQUIPMENT

B.1 WHAT ARE TEST CONNECTIONS?

Test connections are any permanent or temporary attachment points where the AOV Data Acquisition System can measure information about a valve assembly or input a control signal. This Appendix addresses the test connections that are either electrical or pneumatic; although there might be others, these are the predominant connections for AOV testing.

B.2 TYPES OF SIGNALS

In most cases the signals that are measured by the AOV Data Acquisition System are either electrical or pneumatic. Electrical signals are normally milliamperes (0 to 60 in a number of different ranges) or volts, direct current, and 0 to 10 volts or millivolts. Pneumatic signals range from 0 to 120 psig, depending on the plant's compressed air supply system.

B.2.1 Electrical Signals

Test measuring instruments, such as flow meters, pressure or level transducers, stroke or rotational displacement instruments, or thermocouples, put out an electrical signal that can be accepted as-is or modified to be accepted by the Data Acquisition Systems. These electrical signals then have to be converted by the Data Acquisition Systems to engineering units so they can be evaluated and plotted.

Some of the Data Acquisition Systems accept only a number of DC voltages, such as ± 10 volts, in which case any milliamperage signal will have to be modified. This is a relatively safe and easy modification, which can be either permanent or temporary, and which entails incorporating a dropping resistor in series with the electrical signal. The size of the resistor is calculated as follows:

$$\text{Resistor} = \text{Volts} / \text{Current} \quad (R = V/I)$$

If the maximum signal that the Data Acquisition System can take is 10 volts DC and the maximum signal that the milliamperage signal will reach is 50 milliamperes, then the above equation becomes:

$$R = 10 \text{ volts} / 0.050 \text{ amps} = 200 \text{ ohms}$$

Depending on the Data Acquisition System, it might be prudent to include a little margin so that the equipment is not seeing the full 10 volts at 50 milliamperes. For example, use a 180 ohm resistor instead of the 200 ohms. This means that when the instrument puts out a 50 milliampere signal, the Data Acquisition System will read 9 volts.

$$0.050 \text{ amps} * 180 \text{ ohms} = 9 \text{ volts DC}$$

One consideration should be the power that the instrument is capable of putting out. For example, the power required for the above example would be:

$$\text{Power} = VI \text{ or } I^2 R$$

$$9 \text{ volts} * 0.050 \text{ amps} = 0.45 \text{ watts}$$

The instrument sending the signal should be checked to determine that the added power consumption will not overload it.

CAUTION: When working with electrical signals, exercise extreme caution to make sure that neither the technician nor the Data Acquisition System grounds out the control signal, that is, the Data Acquisition System must have a floating ground.

B.2.2 Pneumatic Signals

Some of the Data Acquisition Systems use internal pressure; the others use external pressure transducers that usually attach close to the pressure lines and then send an electronic signal to the Data Acquisition System for measuring and conversion.

When using these transducers there are a few precautions that should be observed:

- Do not use the transducer for measuring a higher pressure than it is meant to see.
- Make sure that the fittings are all tight, per the manufacturer's recommendations.
- When hooking up the tubing to an operating system, hook up the Data Acquisition System side first, then hook up the component side, and be ready to disconnect quickly if something goes wrong.

NOTE: Although relatively small, the volume inside the length of tubing momentarily decreases the pressure that is being measured. When connecting into an instrument such as an I/P transducer, make sure that the connection and disconnection are made positively and quickly so that the signal is not disturbed too much. There will be a very minor transient, which in most cases the valve will not respond to.

- When using tubing that is susceptible to heat or possibly being cut, make sure that the tubing does not come in contact with hot pipes, is not cut by machinery, or placed where it could be stepped on.

B.3 BENEFITS OF PERMANENT TEST CONNECTIONS

Some of the advantages of permanent test connections are:

- **Making connections more quickly.** With either pneumatic fittings or electrical terminal blocks, connections can be made in seconds, rather than minutes or even hours.
- **Hooking up while on line.** With either pneumatic fittings or electrical terminal blocks, connections can be made with little concern about interrupting the system operation.
- **Obtaining the same connection location each time.** With the test connections already installed, the test results from one test sequence to another are not affected. This improves overall repeatability of the testing.
- **Saving time and money.** Time is saved in getting approval to install and remove, and looking around for and connecting fittings to set up temporary test connections to the component for the testing. In addition to the cost of the time to set up the temporary test connection, there is also the cost of the fittings used. Most fittings don't go back to stores but are disposed of.
- **Finding other uses for test connections.** Plants that already have installed test connections on instruments such as positioners or I/Ps have found a secondary benefit in that they can now hook up calibrated gauges quickly to these locations to obtain information or to calibrate the instrument.

There are a number of different types of test connections that can be used with the Data Acquisition System equipment. For example, electrical connections can be set up with terminal strips that are mounted internal or external to the component, and pneumatic lines can be set up with a tee, quick disconnect or miniature shut-off valve, and an end cap.

One plant installed terminal blocks inside some of their I/Ps with a resistor in series with the controller signal. This way the Data Acquisition System can be connected to both sides of the resistor to measure a voltage that is then correlated to the milliampere signal being sent by the controller.

CAUTION: No Data Acquisition System is completely non-intrusive. Extreme caution must be used at all times when hooking up any equipment. The above electrical connection is relatively safe unless the leads are grounded. Quick disconnects are safe until there is a leak in the connection air line. The person hooking up the equipment must be aware of the potential problems and be ready to take counter measures.

B.4 LOCATION OF THE PNEUMATIC TEST TEES

The location of the test tees is important to the quality of the data. The following are general rules to use when determining the location of a test tee in a pneumatic line:

- Whenever possible, measure the pressure that you say you are measuring. For example, do not measure the pressure coming out of the positioner and going to the volume booster and indicate that the pressure is the actuator pressure. Although the signal coming from the positioner is what the actuator should be reading, the actuator pressure normally lags behind the positioner output pressure by quite a bit.
- When measuring high transfer volume lines, get as close as possible to the component that is being measured so that line or component pressure drops do not affect the data. Do not measure upstream of a solenoid-operated valve (SOV) or just downstream of the positioner to get the actuator pressure.
- Always use fittings that are equal to or larger than the tubing going to the fitting. It is important that the fitting not become the restriction to the component.

The following are some suggested locations for test tees for different valve components and the reasons for these locations:

- Actuator pressure
 - Use a second port in the actuator, if available, to measure the actuator pressure. The actual internal actuator pressure will be measured more accurately.
 - If a second port is not available, locate the tee as close to the actuator as physically possible. This eliminates any component or tubing pressure drops.
- Supply pressure. Measure this as close as possible to the component distributing the highest volume of air. Examples:
 - Just upstream of a volume booster supplying an actuator
 - Just upstream of an SOV supplying an actuator
 - Just upstream of a positioner supplying an actuator
- Regulated supply pressure. Same rule as above, but in most cases this is normally used to supply air to the positioner, so it should be just upstream of the positioner.
- Air signal pressures. These are pressures that are used to send a control signal to another component, for example, I/P to a positioner; positioner to a volume booster; or a level, temperature, or pressure controller to a positioner. In all of these cases, the sending unit is sending only a pressure signal to the next unit. There is very little, if any, volume that is transferred in this line. The pressure anywhere in that line should be the same, free from any pressure drop, so the pressure can be measured anywhere along the length of the line.

B.5 GENERIC PROCEDURE FOR INSTALLING QUICK DISCONNECTS

The following procedure, *Installation of Test Fittings on Non-Safety Related Air Operated Valves*, is provided by Toledo Edison's Davis-Besse Nuclear Power Station. This procedure, as it says, is for non-safety AOVs. Safety-related valves at Davis-Besse, as in most other plants, are addressed individually.

Currently one change is being made to the following procedure and that is to add another quick disconnect upstream of the regulator to be used as a source of supply air to the Data Acquisition System if it is needed to drive the AOV. This is a very good suggestion, with the following precaution: Make sure that the line upstream of this connection has enough of a supply so that if the Data Acquisition System is demanding air at the same time the valve is demanding air, the result is not interfering with the proper operation of the valve.

Davis-Besse has tried to standardize on Parker fittings and quick disconnects; Swage is used by other plants as a standard. It is suggested and recommended by the manufacturers that the fittings not be intermixed; although in a pinch, they seem to work well together.

Davis-Besse Nuclear Power Station

INSTRUMENTATION AND CONTROL PROCEDURE

DB-MI-09071

INSTALLATION OF TEST FITTINGS ON NON-SAFETY RELATED AIR OPERATED VALVES

REVISION 00

Prepared by: David R. Colvin 5/27/92
Date

Sponsor: Joe Rogers 5/29/92
IIC Superintendent Date

Approved by: [Signature] 5/28/92
Plant Maintenance Manager Date

Effective Date: MAY 29 1992

Procedure Classification:

- Safety Related
- Quality Related
- Non-Quality Related

INSTALLATION OF TEST FITTINGS ON NON-SAFETY RELATED AIR OPERATED VALVES

TABLE OF CONTENTS

	<u>Page</u>
1.0 PURPOSE	4
2.0 REFERENCES	4
3.0 DEFINITIONS	4
4.0 LIMITS AND PRECAUTIONS	6
5.0 PREREQUISITES	7
6.0 TOOLS AND EQUIPMENT	8
7.0 ACCEPTANCE CRITERIA	9
8.0 PROCEDURE	10
9.0 RECORDS	11
ENCLOSURE 1. Maximum Permissible Span Criteria	12
ENCLOSURE 2. Quick Disconnect Adapter Details	13
ENCLOSURE 3. Air Operated Valve Control Loop Index	14
ENCLOSURE 4. Quick Disconnect Relative Locations	17
ENCLOSURE 5. Signoff Sheets	46

1.0 PURPOSE

- 1.1 This procedure shall be used as a guide for the installation of Quick Disconnect fittings for connection of the VTS-500 Air Operated Valve Tester and the air operated valve under test.
- 1.2 This procedure also gives the planner guidance in the preparation of Maintenance Work Orders for the installation of the quick disconnects on the selected air operated valves. This procedure will give the relative location, standard connection diagrams, standard bill of materials and connection support requirements for seismic considerations.
- 1.3 This procedure also provides a listing of the valves critical to the operation of the plant and the category of the valve as assigned by the Air Operated Valve Task Force.

2.0 REFERENCES

2.1 Developmental

- 2.1.1 RFA-89-0109, Civil Engineering Disposition to adding quick disconnect test fittings to air operated valves, dated May 18, 1989.
- 2.1.2 RFA-89-1142, I&C Design Engineering Disposition to adding quick disconnect test fittings to air operated valves, dated August 1, 1989.

2.2 Implementation

- 2.2.1 DB-OP-00020, Temporary Modifications
- 2.2.2 DB-OP-00015, Safety Tagging
- 2.2.3 DB-MM-09027, Installation and Maintenance of Flareless Compression and 37 Degree Flared Type Tube Fittings.

3.0 DEFINITIONS

- 3.1 PLANT AREAS - location identifiers for general plant locations:
 - 3.2.1 AREA 1 - Turbine room, NE Quadrant
 - 3.2.2 AREA 2 - Turbine room, SE Quadrant
 - 3.2.3 AREA 3 - Turbine room, NW Quadrant
 - 3.2.4 AREA 4 - Turbine room, SW Quadrant
 - 3.2.5 AREA 5 - Heater Bay area

- 3.2.6 AREA 6 - Aux. Bldg., NE Quadrant
 - 3.2.7 AREA 7 - Aux. Bldg., SE Quadrant
 - 3.2.8 AREA 8 - Aux. Bldg., SW Quadrant
 - 3.2.9 AREA 9 - Containment Bldg.
- 3.3 VALVE CATEGORY - a number assigned to each air operated valve by the Air Operated Valve Task Force to relate the importance of the valve in the operation of the plant:
- 3.3.1 CATEGORY 1 - Failure results in the loss of redundancy or places the unit into alert period for Limited Condition for Operation by the Technical Specifications.
 - 3.3.2 CATEGORY 2 - Failure causes a forced outage for repair or results in limited megawatt power output.
 - 3.3.3 CATEGORY 3 - Failure results in a challenge to a safety system or causes a plant trip.
 - 3.3.4 CATEGORY 4 - Failure may cause an undesirable transient or decreases reliability of the system.
 - 3.3.5 CATEGORY 5 - Failure requires operators to make undesirable exceptions, realignments or invoke alternate procedures.
 - 3.3.6 CATEGORY 6 - Failure is chronic; requires excessive maintenance effort.
 - 3.3.7 CATEGORY N/A - None of the above criteria apply.
- 3.4 QUICK DISCONNECT - a tubing fitting that allows the connection and disconnection of pneumatic lines without removing the attached component from service.
- 3.5 VTS-500 - an air operated valve diagnostic testing and data acquisition system.
- 3.6 MAXIMUM PERMISSIBLE SPAN - the maximum distance between the centerline of test connection installation location and the nearest 3-way tubing support or equipment connection.

4.0 LIMITS AND PRECAUTIONS

4.1 Administrative

- 4.1.1 MWO package should be checked for equipment locations to determine where any of the following hazards exist:
- a. High noise levels may exist in some work areas. These work areas should be identified. Ear protection should be worn to avoid injury.
 - b. High or negative pressure conditions may exist in some work areas. These work areas should be identified. Precautions should be taken to avoid injury.
 - c. High temperature conditions may exist. Tasks where equipment is hot or steam conditions exist should be identified. Safety practices should be complied with to avoid burns.
 - d. Heat exhaustion hazards from high temperature conditions may exist in some work areas. These work areas should be identified. Safety practices specifying time limitations for work conducted under high temperatures should be complied with.
 - e. High voltage hazards may exist. Procedure steps where high voltage conditions exist should be identified. Safety practices should be complied with to minimize shock hazards.
 - f. Airborne radiation hazards may exist in some work areas. These work areas should be identified. Protective clothing should be worn and other radiological control practices should be complied with to minimize exposure.
 - g. Radiation contamination hazards may exist. Procedure steps which involve work with contaminated materials should be identified. Radiological control practices for containing, handling, and disposal should be complied with to minimize exposure.
- 4.1.2 Shift Supervisor should be contacted for additional instructions concerning plant status when plant conditions change or after delays in work.

- 4.1.3 A Work Request or follow-up MWO should be initiated for any additional work determined to be necessary during performance of this procedure, but not covered under this procedure.

4.2 Equipment

- 4.2.1 The installation of quick disconnects using this procedure is only allowed for non-safety related and non-seismic air operated valves.
- 4.2.2 If the implementation of this procedure is not complete, then all tubing and equipment shall be returned to normal or tagged in accordance with DB-OP-00020, Temporary Modifications.
- 4.2.3 Installation of quick disconnects to air operated valves in the turbine building (Areas 1, 2, 3, 4 & 5) may be located as tubing configuration permits, no generic locations are required.
- 4.2.4 Installation of quick disconnects to air operated valves in the auxiliary or containment buildings (Areas 6, 7, 8 & 9) shall not exceed the maximum permissible span between the centerline of the quick disconnect assembly and the nearest 3-way tubing support or equipment connection. Maximum permissible spans for Areas 6, 7, 8 & 9 are listed in Enclosure 1.
- 4.2.5 For installations in which the maximum permissible spans can not be met, an evaluation by Design Engineering - Civil/Structural will be required.
- 4.2.6 An evaluation will be required by Design Engineering - Civil/Structural for any installations at an elevation higher than listed in Enclosure 1.

5.0 PREREQUISITES

5.1 Administrative

- (SO) 5.1.1 Obtain Shift Supervisor's permission to perform this procedure.
- (SO) 5.1.2 Notify Shift Supervisor of any alarms or indications that will result from the stroking of the air operated valve being worked on.
- (SO) 5.1.3 Obtain an RWP, if applicable.
- (SO) 5.1.4 Prior to starting work, notify Quality Control, if applicable.

- (SO) 5.1.5 Establish communications as necessary.
- (SO) 5.1.6 The user of this procedure has read and understands all of its contents.

5.2 Equipment

- (SO) 5.2.1 Verify the air operated valve being worked on is isolated and tagged in accordance with DB-OP-00015, Safety Tagging AND that the associated tubing is depressurized.
- (SO) 5.2.2 Notify RC Supervisor if a radiologically controlled system boundary may be broken.

6.0 TOOLS AND EQUIPMENT

NOTE 6.1

Refer to Enclosure 2 for diagram of parts listed below. The swage fittings may be substituted with an equivalent parker fitting.

6.1	<u>Suggested Parts List</u>	<u>Vendor Part #</u>	<u>Stock Code</u>
6.1.1	A) Tee 3/8" T Swage	B-600-3TTF	T301546
6.1.2	B) Female Branch Run 3/8" Swage	B-600-3TFT	T301277
6.1.3	C) Male Pipe Quick Coupler, Parker	4M-Q4CN-B	T301544
6.1.4	D) Coupler Protector, Parker	CP-Q4C-B	T300805
6.1.5	E) Male Connector 3/8" to 1/4"	B-600-1-4	T302257
6.1.6	F) Union Adapter 3/8" to 1/4"	B-600-6-4	T302881
6.1.7	G) Copper Tubing		
6.1.8	H) Stainless Steel Wire		T330537
6.2	<u>Consumable Materials</u>		
6.2.1	Leak-Tek or equivalent		

6.3 Special Tools and Equipment

6.3.1 VTS-500 air test set system

7.0 ACCEPTANCE CRITERIA

- 7.1 For air operated valves in Areas 6, 7, 8 or 9 the quick disconnects installed do not exceed the maximum span criteria listed in Enclosure 1.
- 7.2 The quick disconnects installed are accessible for the connection and disconnection of test tubing.
- 7.3 The relative locations of the quick disconnects are installed in accordance with the appropriate figure in Enclosure 4.
- 7.4 When Leak-Tek (or equivalent) is applied, no visible air leakage is observed from the valve tubing or tubing connections.
- 7.5 The protective caps of the quick disconnects are installed and captured to prevent their loss.

8.0 PROCEDURE**8.1 Setup**

- 8.1.1 Ensure all parts and materials needed for the installation of the quick disconnects are available. Refer to section 6.1 for a partial list of fittings and parts.
- (SO) 8.1.2 Using the appropriate Enclosures measure the valve tubing and determine the location where each quick disconnect will be installed, or if valve location not specified by Enclosures see Performance Engineer or Maintenance Staff Engineer for appropriate quick disconnect relative location.
- (SO) 8.1.3 Ensure that the quick disconnect locations marked will be adequately supported.
- (SO) 8.1.4 If the valve is in Areas 6,7,8 or 9, ensure that the maximum permissible span criteria of Enclosure 1 will be met. N/A this step if the valve is in Areas 1,2,3,4 or 5.
- (SO) 8.1.5 Ensure that the quick disconnect locations marked will be accessible for connection and disconnection of test tubing.

8.2 Installation

- (SO) 8.2.1 Install the quick disconnects in the locations determined in step 8.1.2, and in accordance with DB-MM-09027.

NOTE 8.2.2

See Enclosure 2.

- (SO) 8.2.2 Install COUPLER protector to quick coupler AND secure coupler protector to quick coupler using stainless steel wire.

8.3 Installation Verification

- 8.3.1 Open the appropriate local air supply isolation valve and re-pressurize the tubing.
- (SO) 8.3.2 Perform a leak check of the tubing and the tubing connections by using Leak-Tek (or equivalent). Ensure that there are no visible leaks.

- 8.3.3 Verify the following criteria are met for the quick disconnect installation:
- (IV) 8.3.3.1 The installation meets the maximum span criteria of Enclosure 1. N/A this step if the valve is in Areas 1, 2, 3, 4 or 5.
 - (IV) 8.3.3.2 The quick disconnects are accessible for the connection and disconnection of test tubing.
 - (IV) 8.3.3.3 The relative location of the quick disconnects match the appropriate figure of Enclosure 4.
 - (IV) 8.3.3.4 The protective caps of the quick disconnects are installed and captured to prevent their loss.

8.4 Restoration

- (SO) 8.4.1 Stroke the valve using the VTS-500 test system to verify proper operation.
- (SO) 8.4.2 Notify Shift Supervisor the quick disconnects have been installed and the valve may be returned to service.

9.0 RECORDS

- 9.1 The records generated by this procedure consist of a Signoff Sheet.
 - 9.1.1 Enter N/A, initial, and date any step(s) not performed (which are identified on Signoff Sheets as (SO) or (IV)) and state in comment section of Signoff Sheet the reason for not performing step(s).
 - 9.1.2 Submit MWO Package and Signoff Sheets to I&C Supervisor for review.
 - 9.1.3 This procedure has been satisfactorily completed when the I&C Supervisor has reviewed and signed the Signoff Sheet.
- 9.2 Process completed MWO Package and Signoff Sheets in accordance with DB-PN-00007, Control of Work.

ENCLOSURE 1: MAXIMUM PERMISSIBLE SPAN CRITERIA

	<u>FLOOR ELEVATION</u>	<u>MAXIMUM SPAN</u>
AREA: 6	585' - 0"	6"
	603' - 0"	4"
	623' - 0"	4"
	643' - 0"	3"
AREA: 7	545' - 0"	12"
	555' - 0"	12"
	565' - 0"	12"
	585' - 0"	10"
	603' - 0"	6"
	612' - 0"	6"
	623' - 0"	4"
	643' - 0"	4"
	660' - 0"	3"
AREA: 8	565' - 0"	12"
	585' - 0"	10"
	603' - 0"	6"
	623' - 0"	4"
	643' - 0"	2"
	653' - 0"	2"
	660' - 0"	2"
AREA: 9	570' - 9"	12"
	574' - 0"	12"
	578' - 0"	12"
	585' - 0"	12"
	595' - 0"	10"
	603' - 0"	8"
	606' - 0"	8"
	617' - 9"	6"
	624' - 6"	6"
	629' - 6"	4"
	641' - 3"	4"
	653' - 0"	4"

ENCLOSURE 2: QUICK DISCONNECT ADAPTER DETAILS



Used on outlets from regulators, solenoids etc.



Used to reduce from 3/8" to 1/4"

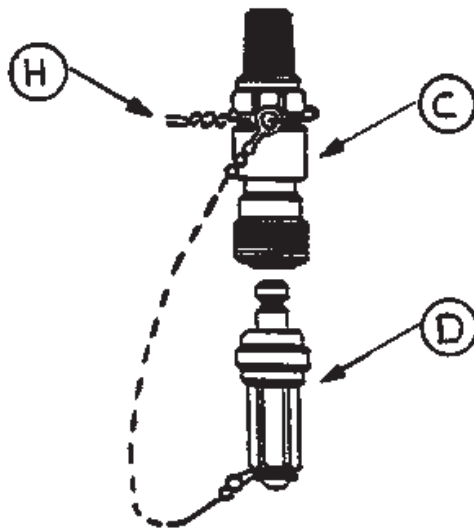
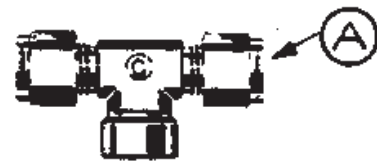
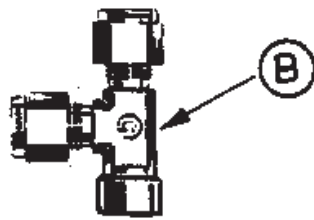

Detail 1
Adapter on run

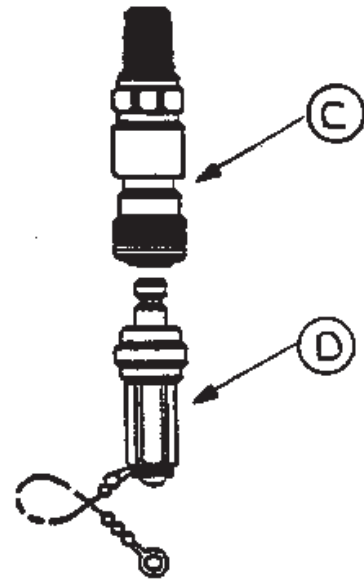

Detail 2
Adapter on branch

ENCLOSURE 3: AIR OPERATED VALVE CONTROL LOOP INDEXNON-SAFETY RELATED VALVES

<u>VALVE NUMBER</u>	<u>CATEGORY</u>	<u>P&ID</u>	<u>STARTUP SYSTEM</u>	<u>FIGURE</u>	<u>ENCLOSURE 4 PAGE #</u>
AS 0958	4,5	004C	047-01	GG	28
AS 1615	4,5	020B	085-06	A	3
AS 1652	4,5	020C	085-09	K	10
AS 1670	4,5	020C	085-06	W	20
AS 1685A	4	020D	085-09	K	10
AS 1685B	4	020D	085-09	K	10
AS 1933	4,5	014	043-01	B	4
AS 2035	4,5	020A	085-09	GG	28
AS 2073	4,5	020E	085-06	GG	28
AS 2076	4,5	006F	035-01	GG	28
AS 2127B	4,5	020C	085-09	B	4
AS 2597	4,5	006F	035-01	GG	28
AS 3748	4	020D	085-01	GG	28
CC 1454	1,5	036C	016-04	L	11
CD 0420	2,3,4,5	006F	035-01	EE	26
CD 0421	2,3,4,5	006F	035-01	EE	26
CD 0593	4,5	006C	036-01	M	12
CD 0940	4,5	006C	036-01	M	12
CD 0961	4,5	006C	036-01	M	12
CD 0963	4,5	006C	036-01	M	12
CF 2864	4,5	038C	051-01	FF	27
CT 2955	4	041A	011-01	T	8
ES 0249	4	004D	046-01	GG	28
ES 0252	4	004B	046-01	GG	28
ES 0256	4,5	004B	046-01	J	9
ES 0264	4,5	004B	046-01	J	9
ES 0278	4,5	004B	046-01	DD	25
ES 0298A	4,5	004D	046-01	J	9
ES 0298B	4,5	004D	046-01	J	9
ES 0308	4,5	004B	046-01	GG	28
ES 0325A	4,5	004C	046-01	J	9
ES 0325B	4,5	004C	046-01	J	9
ES 0341	4	004C	046-01	GG	28
ES 0349	4,5	004B	046-01	J	9
ES 0370	4,5	004B	046-01	J	9
ES 0377	4,5	004B	046-01	J	9
ES 0409	4	004B	046-01	GG	28
ES 0411	4	004C	046-01	GG	28
ES 0413	4	004B	046-01	GG	28
ES 0415	4	004D	046-01	GG	28
ES 0417	4	004B	046-01	GG	28

Enclosure 3
Page 1 of 3













ENCLOSURE 3: AIR OPERATED VALVE CONTROL LOOP INDEX (Continued)NON-SAFETY RELATED VALVES

<u>VALVE NUMBER</u>	<u>CATEGORY</u>	<u>PL&ID</u>	<u>STARTUP SYSTEM</u>	<u>FIGURE</u>	<u>ENCLOSURE 4 PAGE #</u>
ES 9845	4,5	004D	046-01	I	8
ES 9846	4,5	004C	046-01	I	8
FO 1503	4,5	017C	085-10	GG	28
FW 0395	4,5	006C	036-03	BB	23
FW 0423	4,5	006C	045-01	Y	21
FW 0428	4,5,6	006C	036-01	AA	22
FW 0438	4,5,6	006C	036-01	AA	22
FW 0472	4,5	006C	036-01	P	15
FW 0479	4,5	006C	036-01	P	15
FW 0485	4,5	006C	036-01	E	7
FW 0488	4,5	006C	036-01	J	9
FW 0491	4,5	006C	045-01	J	9
FW 1651	4,5	020C	085-08	O	14
GS 1991	4	022A	092-01	Q	16
GS 2167	4,5	004D	092-01	GG	28
GS 2338	4	022A	092-01	M	12
HD 0242	4	004B	047-01	T	18
HD 0261A	2,4,5	004B	047-01	D	6
HD 0271A	2,4,5	004B	047-01	U	19
HD 0291A	2,4,5	004B	074-01	L	11
HD 0300A	4	004D	047-01	BB	23
HD 0300B	4	004D	047-01	NN	29
HD 0311	4,5	004D	047-01	L	11
HD 316	4,5	004D	047-01	R	17
HD 0331A	4	004C	047-01	BB	23
HD 0331B	4	004D	047-01	NN	29
HD 0344	4,5	004C	047-01	R	17
HD 0361A	2,4,5	004B	047-01	C	5
HD 0371A	2,4,5	004B	047-01	U	19
HD 0381A	2,4,5	004B	047-01	C	5
HD 414	4	004B	047-01	Q	16
HD 0953	4,5	004C	047-01	L	11
MS 0138	4,5,6	002A	092-02	GG	28
MS 0266	4,5,6	022A	092-02	GG	28
MS 0338	4	003B	084-01	O	14
MS 0353	4	003B	084-01	O	14
MS 1650	4,5	020C	085-08	L	11
MS 4531	4,5	007A	063-01	CC	24
MS 4532	4,5	007B	063-01	CC	24

ENCLOSURE 3: AIR OPERATED VALVE CONTROL LOOP INDEX (Continued)NON-SAFETY RELATED VALVES

<u>VALVE NUMBER</u>	<u>CATEGORY</u>	<u>P&ID</u>	<u>STARTUP SYSTEM</u>	<u>FIGURE</u>	<u>ENCLOSURE 4 PAGE #</u>
MU 0006	4,5	031A	065-01	K	10
MU 0019	4,5	031C	065-01	K	10
MU 0032	4,5	031C	065-01	K	10
MU 0039	4,5	031A	065-03	K	10
PW 0225B	4,5	040A	064-04	GG	28
PW 3755	4	010D	037-03	K	10
RC 0222	4,5	040A	064-05	GG	28
RC 0225A	4,5	040A	064-05	GG	28
RC 2548	4,5	040A	064-01	GG	28
RC 3605	4,5	040A	064-01	N	13
SW 0630	4,6	041A	011-02	M	12
SW 0631	4,6	041A	011-02	M	12
SW 0632	4,6	041A	011-02	M	12
TD 2368	3,4	022A	092-02	GG	28
TD 2369	3,4	022A	092-02	GG	28
TD 2382	3,4	022A	092-02	GG	28
TD 2383	3,4	022A	092-02	GG	28
TD 4981	4,5	022B	092-03	GG	28
TD 4982	4,5	022B	092-03	GG	28
WG 1819	1,5	038C	072-03	GG	28
WG 1820	1,5	038C	072-03	GG	28
WG 1821	1,5	038C	072-03	K	10
WG 1821A	1,5	038C	072-03	K	10

ENCLOSURE 4: QUICK DISCONNECT RELATIVE LOCATIONS

POSITIONER		FILTER REGULATOR	
QUICK RELEASE		V TO PRESS. CONVERTOR	
SOLENOID VALVE		I TO PRESS. CONVERTOR	
TEST VALVE		PRESSURE INDICATOR	
REGULATOR		LEVEL CONTROL	
AIR BOOSTER		PRESSURE CONTROL	

SYMBOL KEY

ENCLOSURE 4: QUICK DISCONNECT RELATIVE LOCATIONS (Continued)

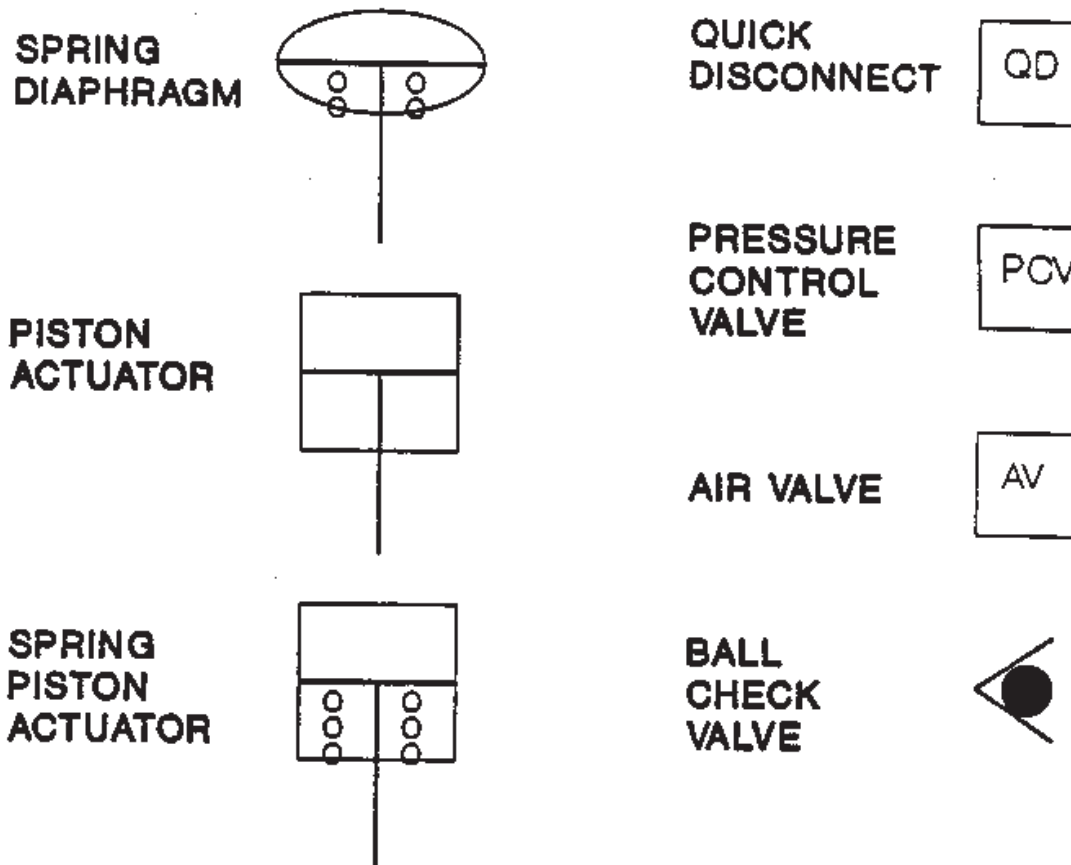

SYMBOL KEY (Continued)

ENCLOSURE 4: QUICK DISCONNECT RELATIVE LOCATIONS (Continued)

NOTE: FOR SYMBOL KEY REFER TO ENCLOSURE 4 PAGES 1 AND 2

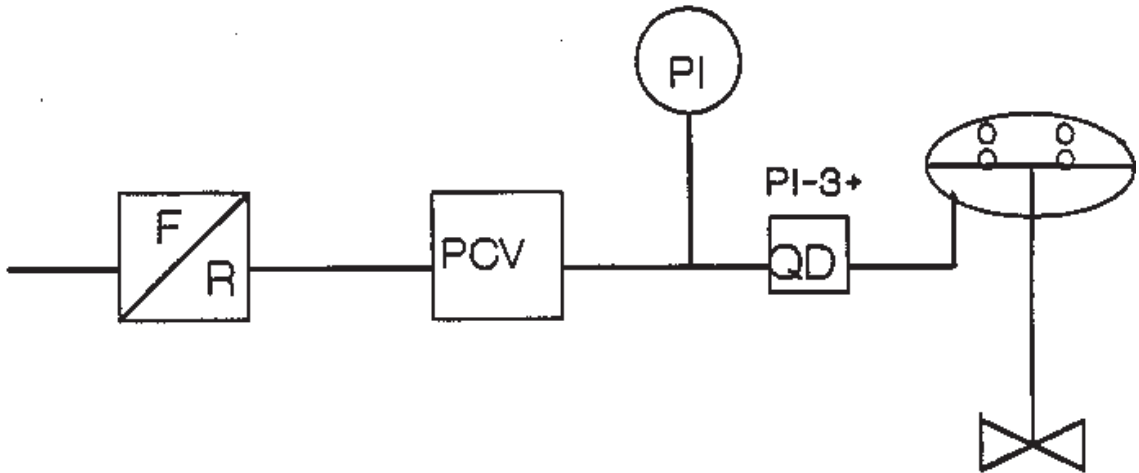

FIGURE A

AS - 1615

ENCLOSURE 4: QUICK DISCONNECT RELATIVE LOCATIONS (Continued)

NOTE: FOR SYMBOL KEY REFER TO ENCLOSURE 4 PAGES 1 AND 2

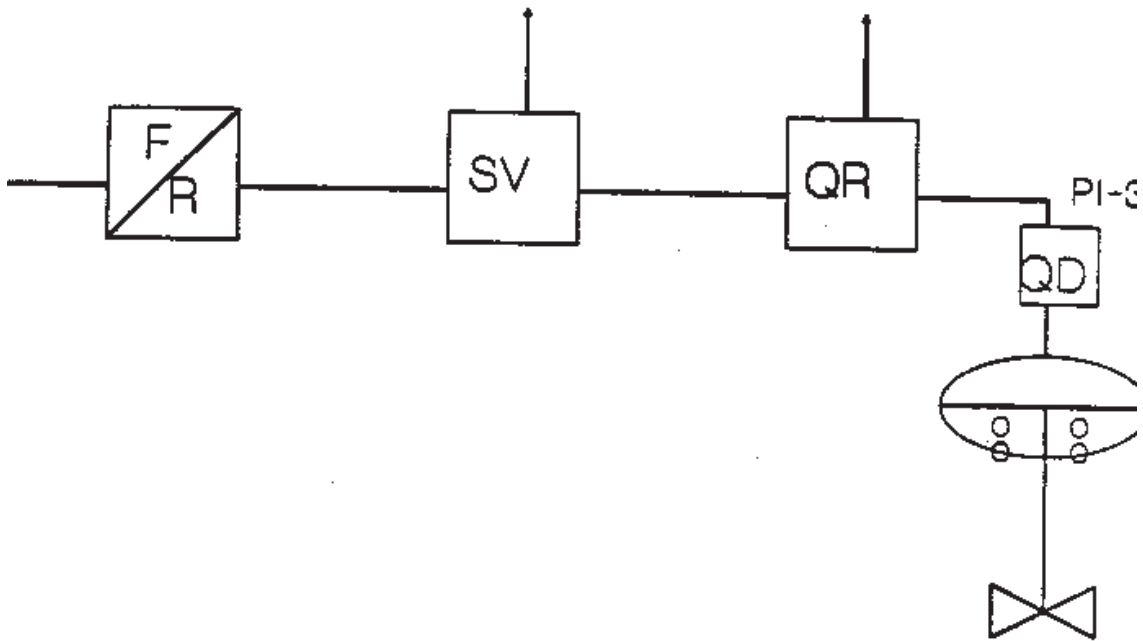

FIGURE B

AS - 1933
AS - 2127B

ENCLOSURE 4: QUICK DISCONNECT RELATIVE LOCATIONS (Continued)

NOTE: FOR SYMBOL KEY REFER TO ENCLOSURE 4 PAGES 1 AND 2

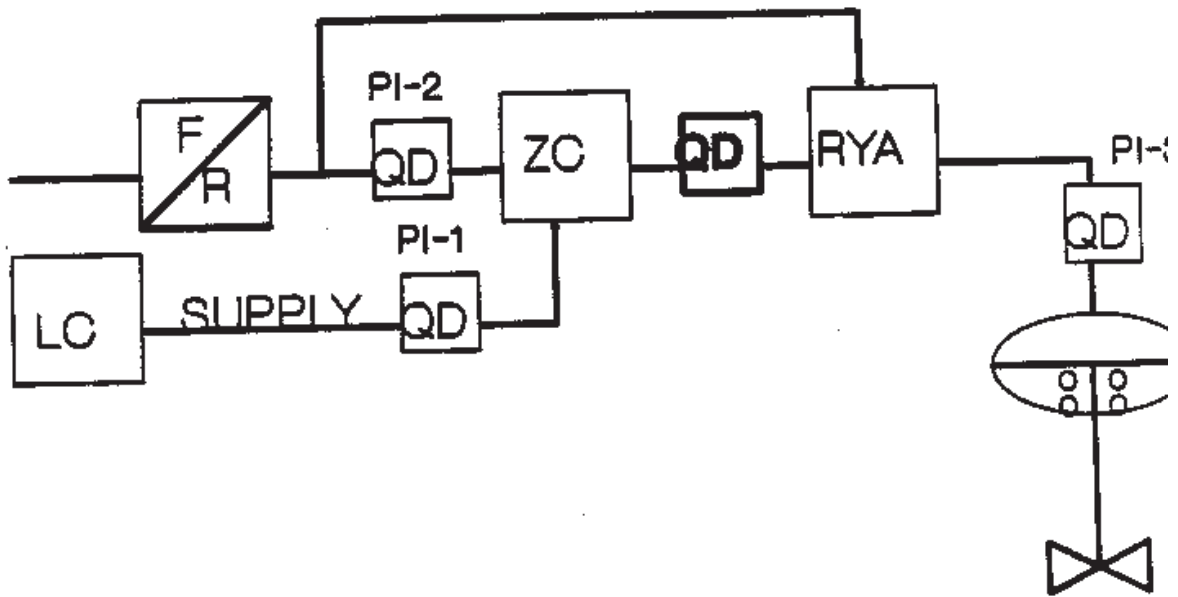

FIGURE C

HD - 361A
HD - 381A

ENCLOSURE 4: QUICK DISCONNECT RELATIVE LOCATIONS (Continued)

NOTE: FOR SYMBOL KEY REFER TO ENCLOSURE 4 PAGES 1 AND 2

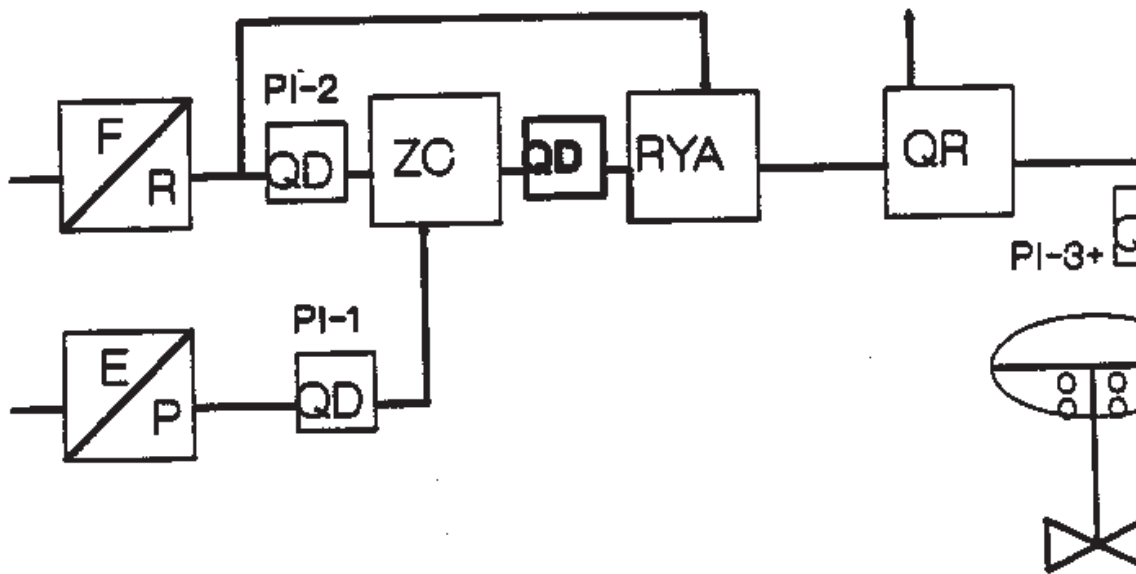

FIGURE D

HD - 261A

ENCLOSURE 4: QUICK DISCONNECT RELATIVE LOCATIONS (Continued)

NOTE: FOR SYMBOL KEY REFER TO ENCLOSURE 4 PAGES 1 AND 2

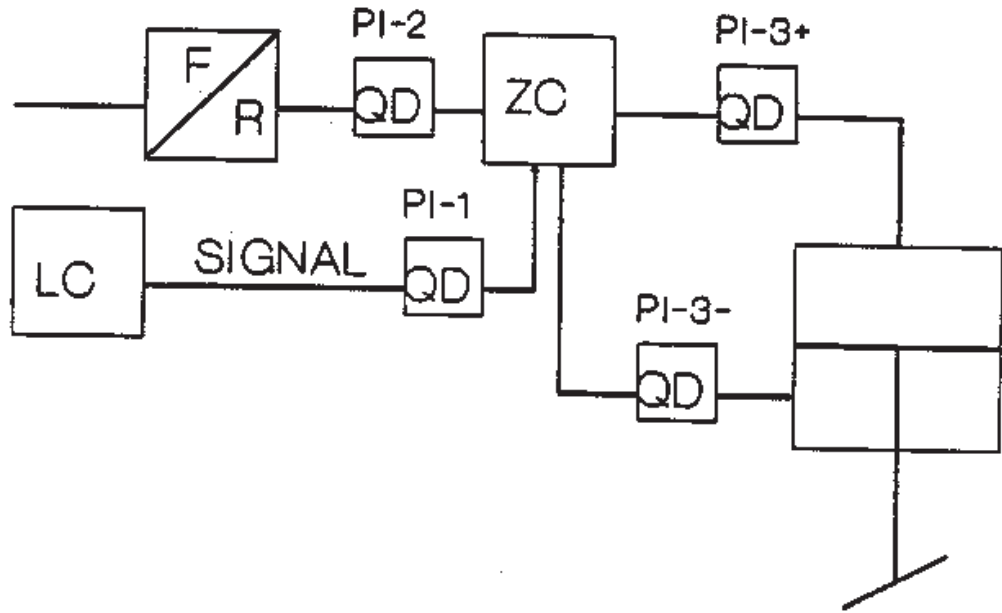

FIGURE E

FW - 485

ENCLOSURE 4: QUICK DISCONNECT RELATIVE LOCATIONS (Continued)

NOTE: FOR SYMBOL KEY REFER TO ENCLOSURE 4 PAGES 1 AND 2

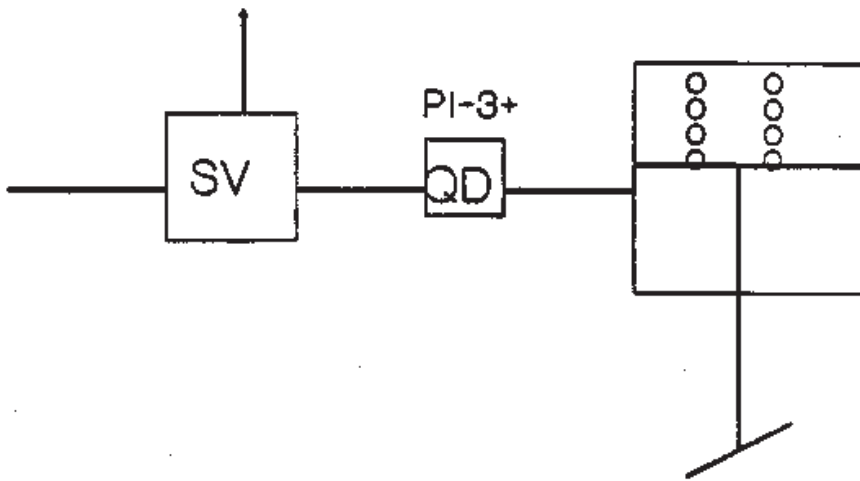

FIGURE 1

- CT - 2955
- ES - 9845 (NRV)
- ES - 9846 (NRV)

ENCLOSURE 4: QUICK DISCONNECT RELATIVE LOCATIONS (Continued)

NOTE: FOR SYMBOL KEY REFER TO ENCLOSURE 4 PAGES 1 AND 2

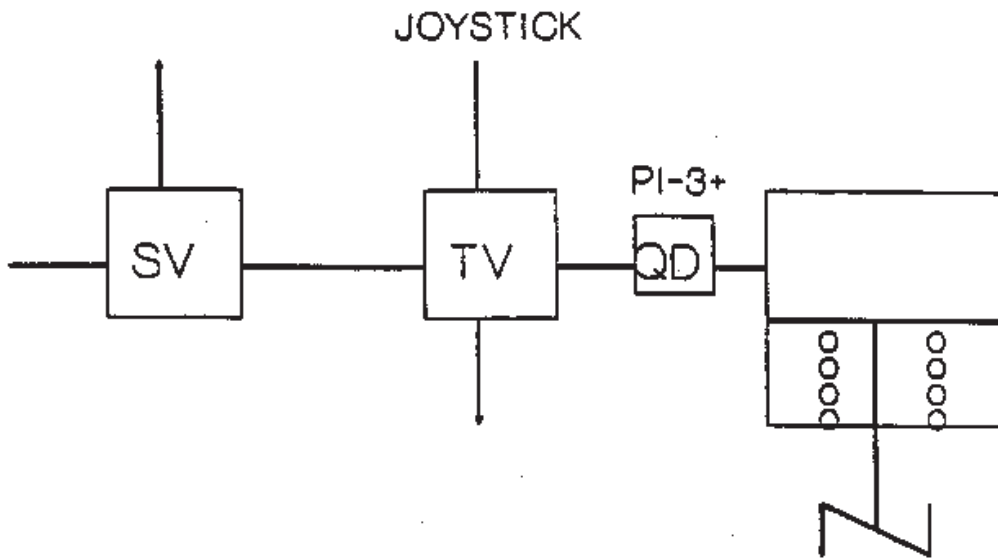

FIGURE J

ES - 256
ES - 264
ES - 298A
ES - 298B

ES - 325A
ES - 325B
ES - 349
ES - 370

ES - 377
FW - 488
FW - 491

ENCLOSURE 4: QUICK DISCONNECT RELATIVE LOCATIONS (Continued)

TYPE: FOR SYMBOL KEY REFER TO ENCLOSURE 4 PAGES 1 AND 2

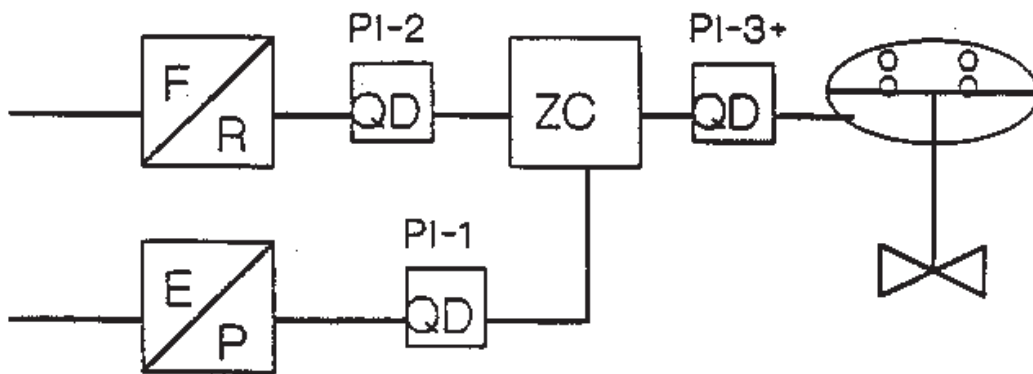

FIGURE K

AS - 1652	MU - 32
AS - 1665A	MU - 39
AS - 1685B	PW - 3755
MU - 6	WG - 1821
MU - 19	WG - 1821A

ENCLOSURE 4: QUICK DISCONNECT RELATIVE LOCATIONS (Continued)

NOTE: FOR SYMBOL KEY REFER TO ENCLOSURE 4 PAGES 1 AND 2

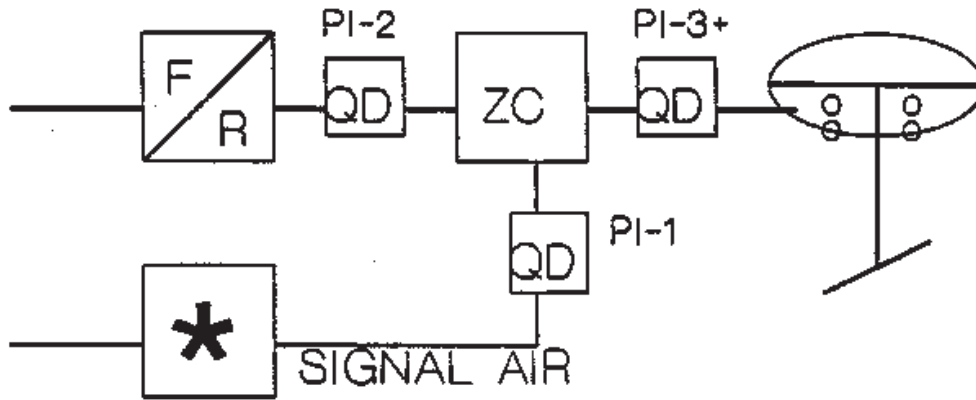

FIGURE 1

- CC - 1454 * (TIC)
- HD - 291A * (LC)
- HD - 0311 * (LC)
- HD - 0953 * (LC)
- MS - 1650 * (PIC)

ENCLOSURE 4: QUICK DISCONNECT RELATIVE LOCATIONS (Continued)

NOTE: FOR SYMBOL KEY REFER TO ENCLOSURE 4 PAGES 1 AND 2

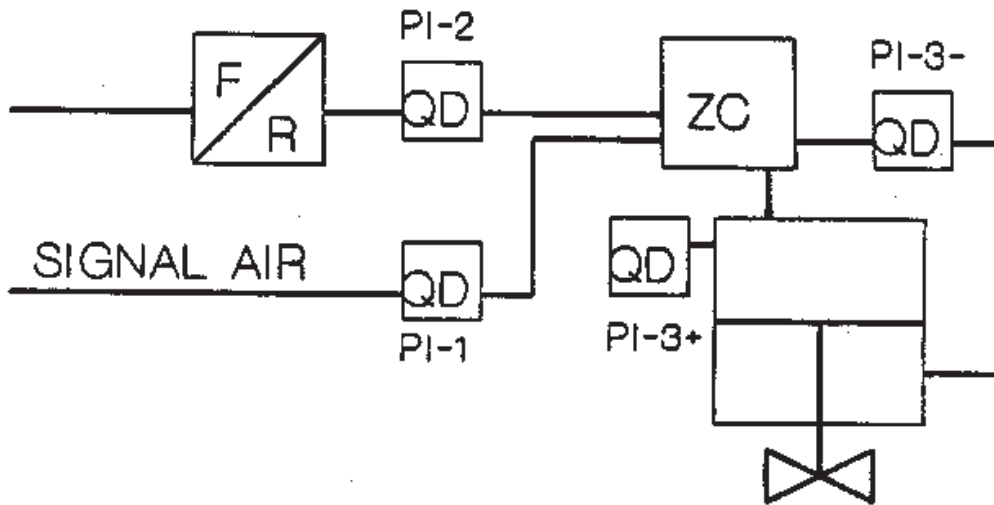

FIGURE M

- | | |
|----------|-----------|
| CD - 593 | GS - 2338 |
| CD - 940 | SW - 630 |
| CD - 961 | SW - 631 |
| CD - 963 | SW - 632 |

ENCLOSURE 4: QUICK DISCONNECT RELATIVE LOCATIONS (Continued)

NOTE: FOR SYMBOL KEY REFER TO ENCLOSURE 4 PAGES 1 AND 2

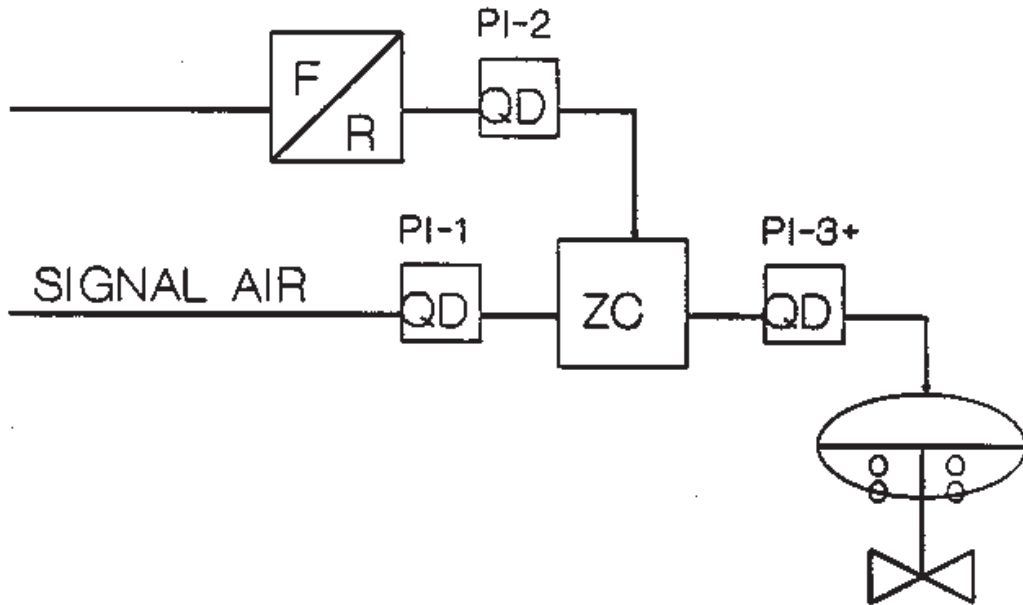

FIGURE N
RC - 3625

ENCLOSURE 4: QUICK DISCONNECT RELATIVE LOCATIONS (Continued)

NOTE: FOR SYMBOL KEY REFER TO ENCLOSURE 4 PAGES 1 AND 2

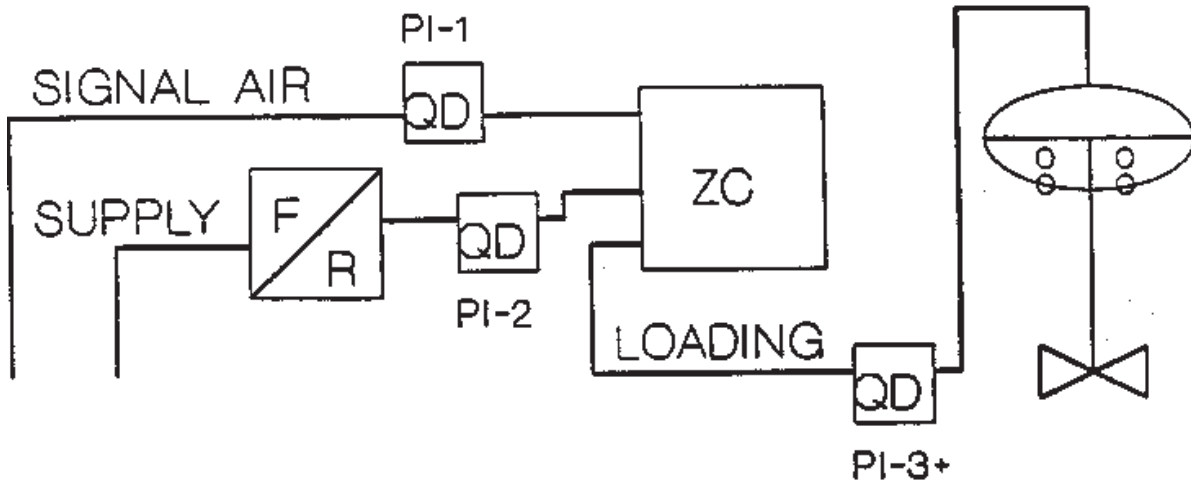

FIGURE 0

FW - 1651
MS - 338
MS - 353

ENCLOSURE 4: QUICK DISCONNECT RELATIVE LOCATIONS (Continued)

NOTE: FOR SYMBOL KEY REFER TO ENCLOSURE 4 PAGES 1 AND 2

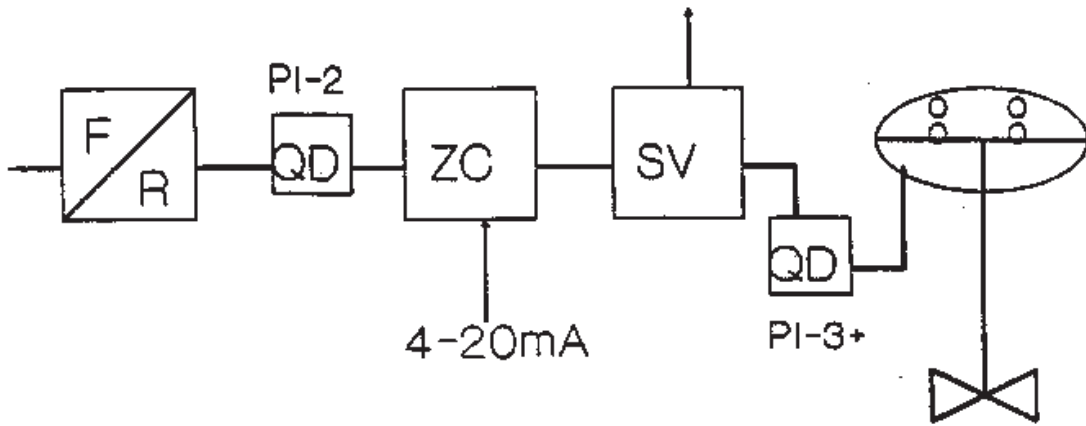

FIGURE P

FW - 472
FW - 479

ENCLOSURE 4: QUICK DISCONNECT RELATIVE LOCATIONS (Continued)

NOTE: FOR SYMBOL KEY REFER TO ENCLOSURE 4 PAGES 1 AND 2

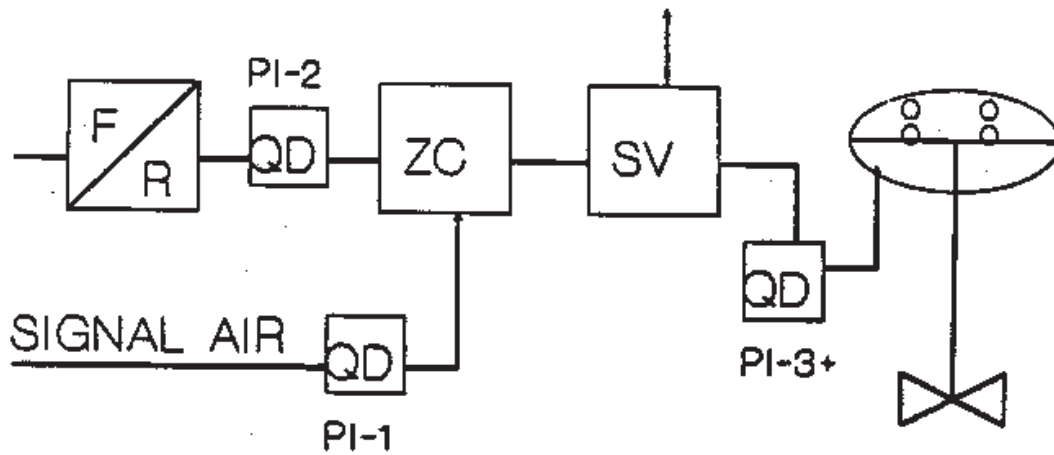

FIGURE Q

GS - 1991
HD - 414

ENCLOSURE 4: QUICK DISCONNECT RELATIVE LOCATIONS (Continued)

NOTE: FOR SYMBOL KEY REFER TO ENCLOSURE 4 PAGES 1 AND 2

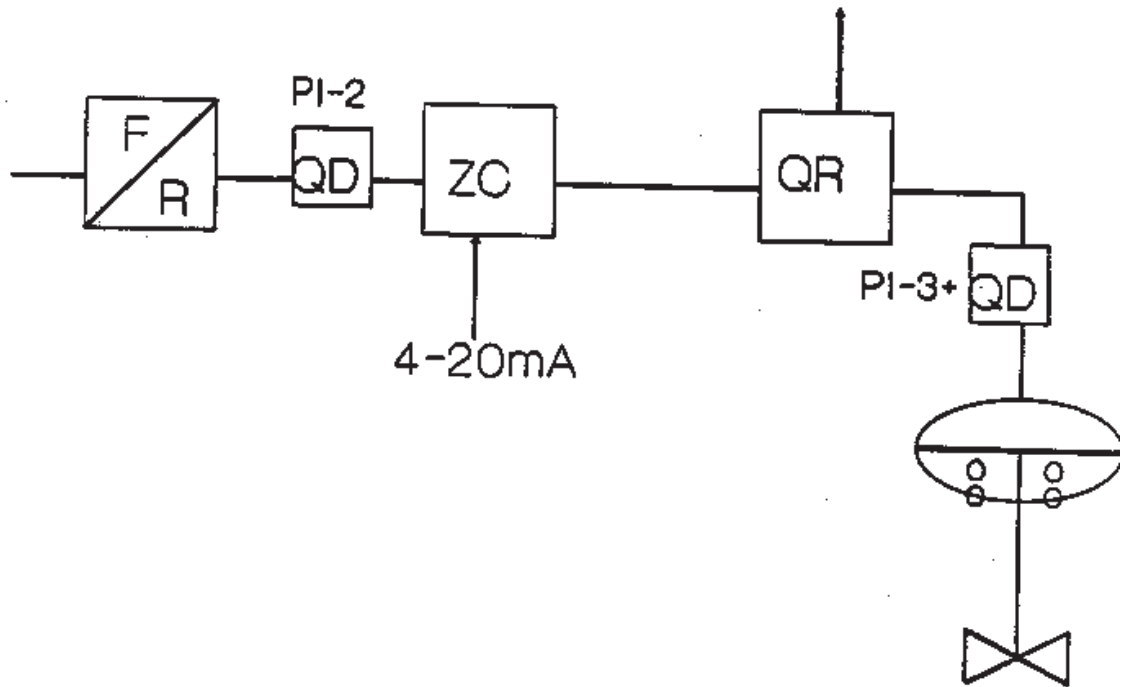

FIGURE R

HD - 316
HD - 344

ENCLOSURE 4: QUICK DISCONNECT RELATIVE LOCATIONS (Continued)

NOTE: FOR SYMBOL KEY REFER TO ENCLOSURE 4 PAGES 1 AND 2

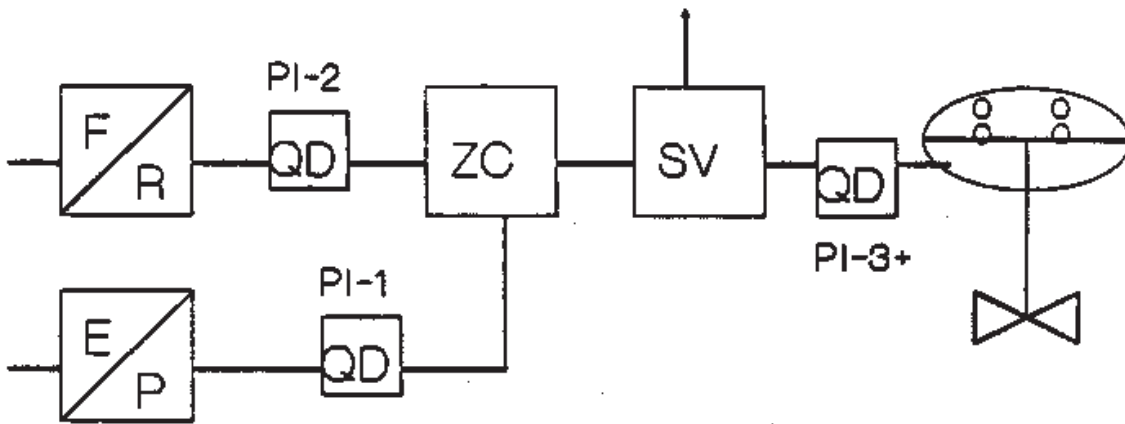

FIGURE 1

ND - 242

ENCLOSURE 4: QUICK DISCONNECT RELATIVE LOCATIONS (Continued)

NOTE: FOR SYMBOL KEY REFER TO ENCLOSURE 4 PAGES 1 AND 2

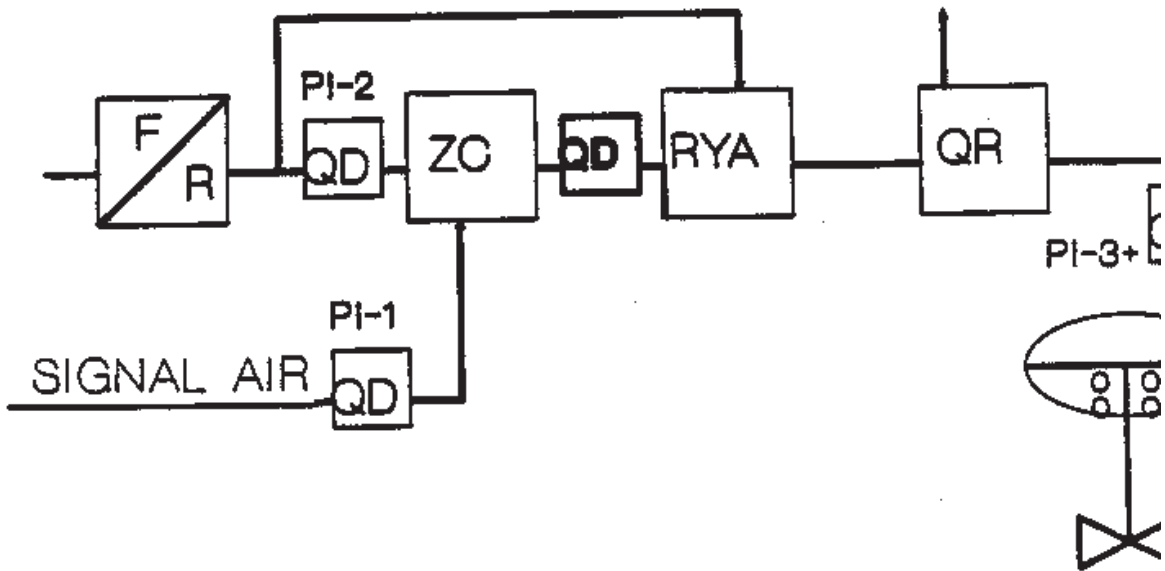

FIGURE U

HD - 271A
HD - 371A

ENCLOSURE 4: QUICK DISCONNECT RELATIVE LOCATIONS (Continued)

NOTE: FOR SYMBOL KEY REFER TO ENCLOSURE 4 PAGES 1 AND 2

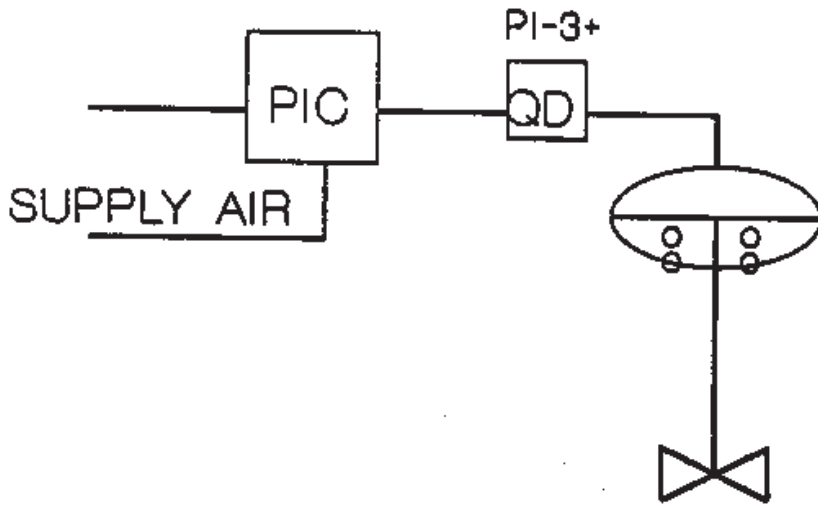

FIGURE W

AS - 1620

ENCLOSURE 4: QUICK DISCONNECT RELATIVE LOCATIONS (Continued)

NOTE: FOR SYMBOL KEY REFER TO ENCLOSURE 4 PAGES 1 AND 2

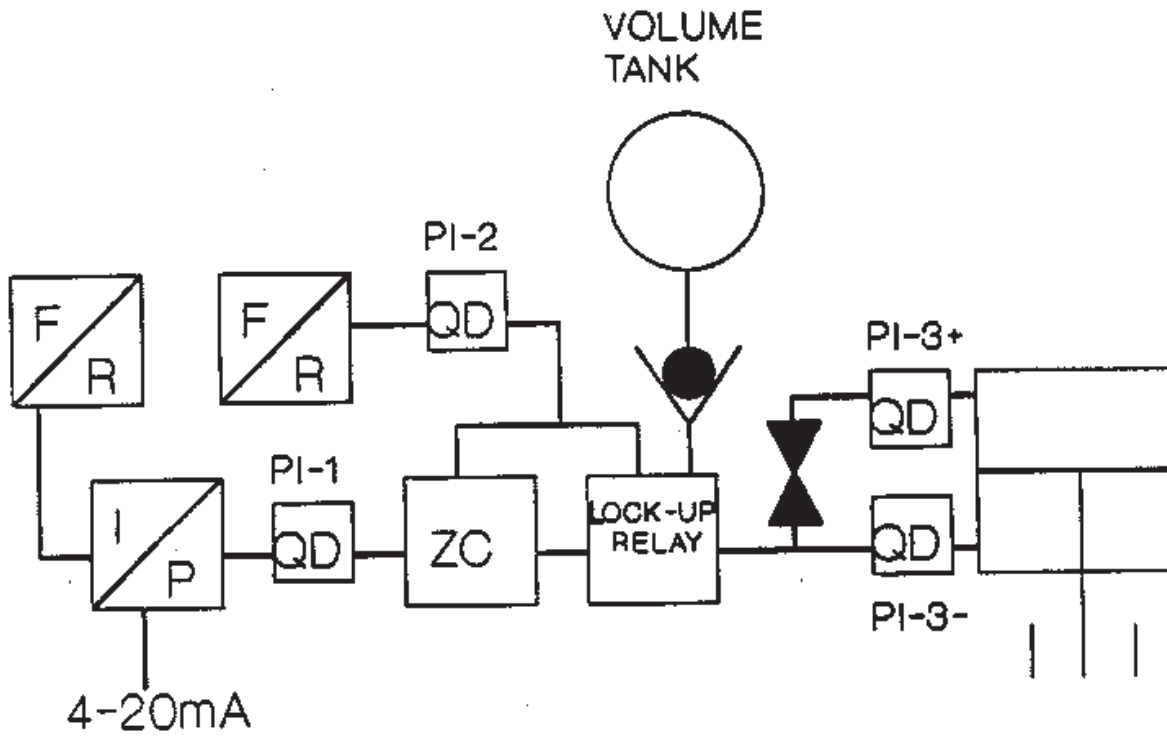

FIGURE Y

FW - 423

ENCLOSURE 4: QUICK DISCONNECT RELATIVE LOCATIONS (Continued)

NOTE: FOR SYMBOL KEY REFER TO ENCLOSURE 4 PAGES 1 AND 2

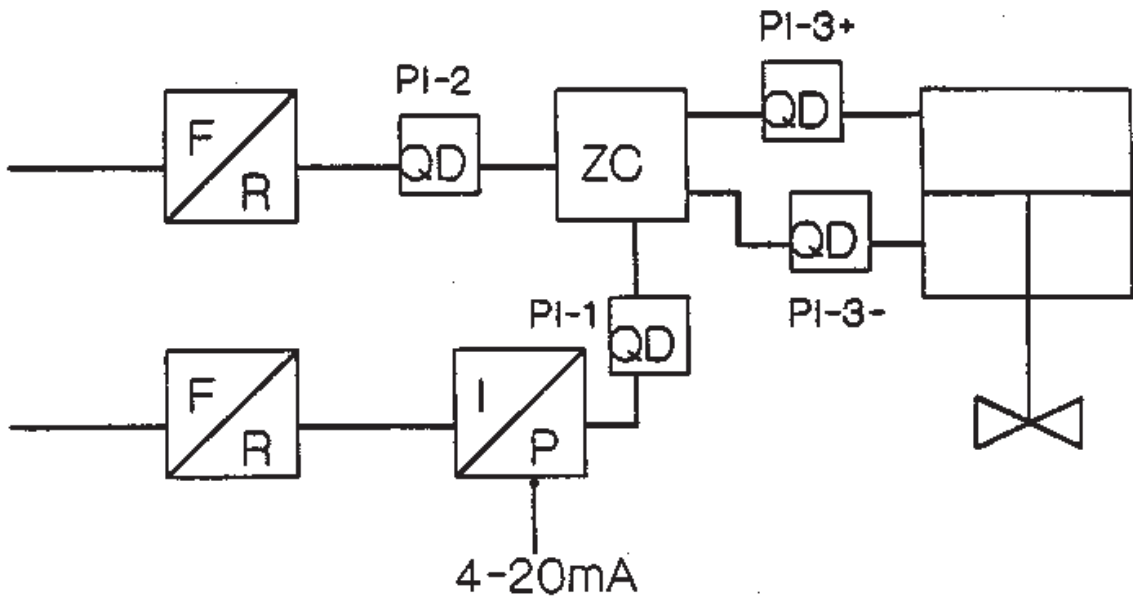

FIGURE AA

PW - 428
PW - 438

ENCLOSURE 4: QUICK DISCONNECT RELATIVE LOCATIONS (Continued)

NOTE: FOR SYMBOL KEY REFER TO ENCLOSURE 4 PAGES 1 AND 2

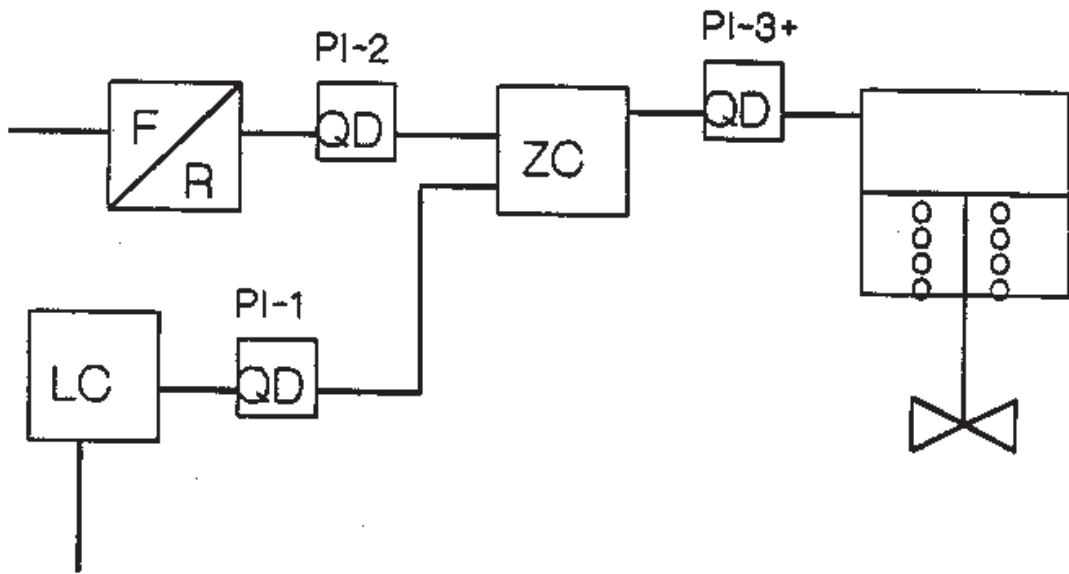

FIGURE B5

FW - 395
HD - 300A
HD - 331A

ENCLOSURE 4: QUICK DISCONNECT RELATIVE LOCATIONS (Continued)

NOTE: FOR SYMBOL KEY REFER TO ENCLOSURE 4 PAGES 1 AND 2

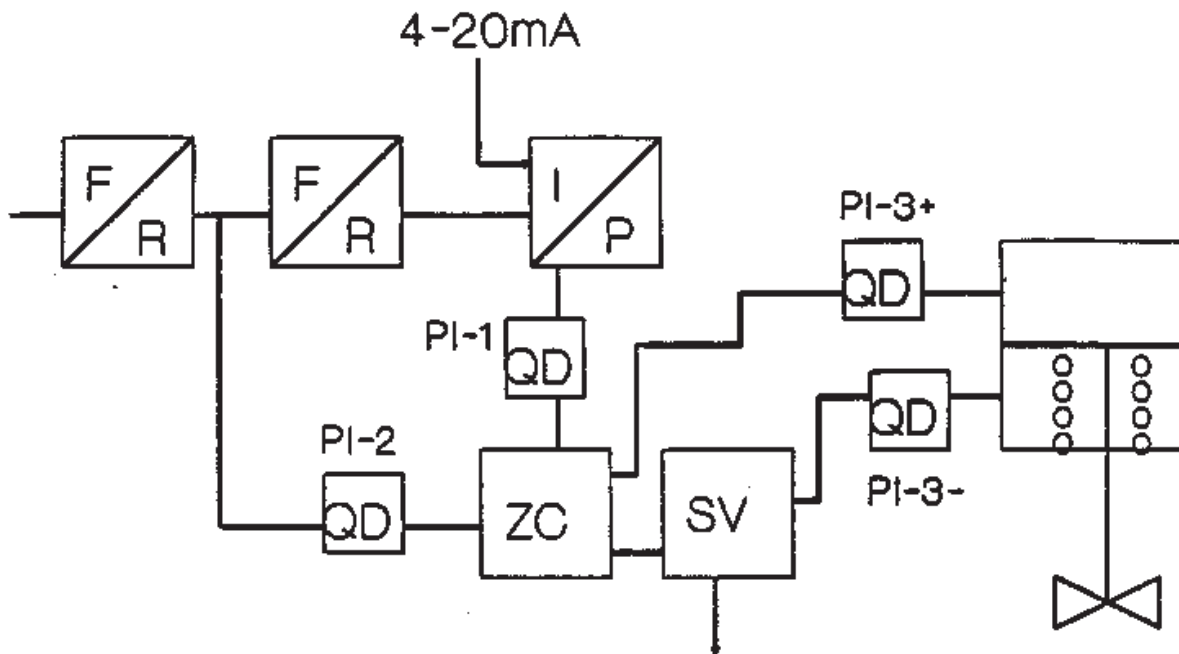

FIGURE CC

MS - 4531
MS - 4532

ENCLOSURE 4: QUICK DISCONNECT RELATIVE LOCATIONS (Continued)

NOTE: FOR SYMBOL KEY REFER TO ENCLOSURE 4 PAGES 1 AND 2

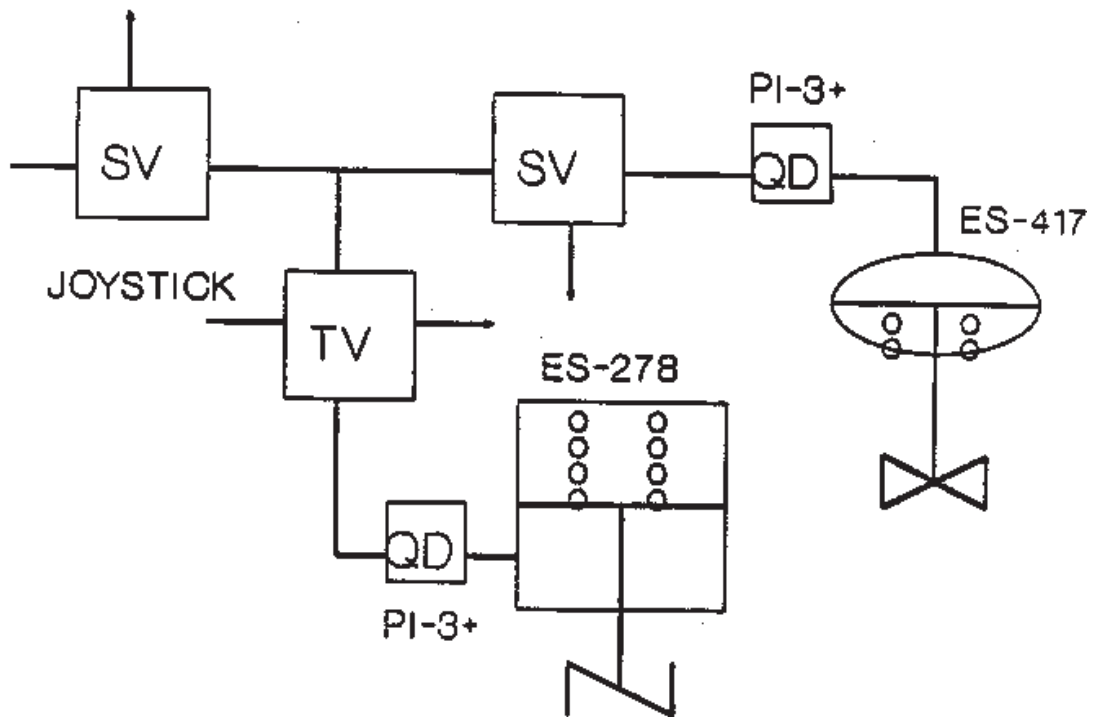

FIGURE 00

ES - 278

ENCLOSURE 4: QUICK DISCONNECT RELATIVE LOCATIONS (Continued)

NOTE: FOR SYMBOL KEY REFER TO ENCLOSURE 4 PAGES 1 AND 2

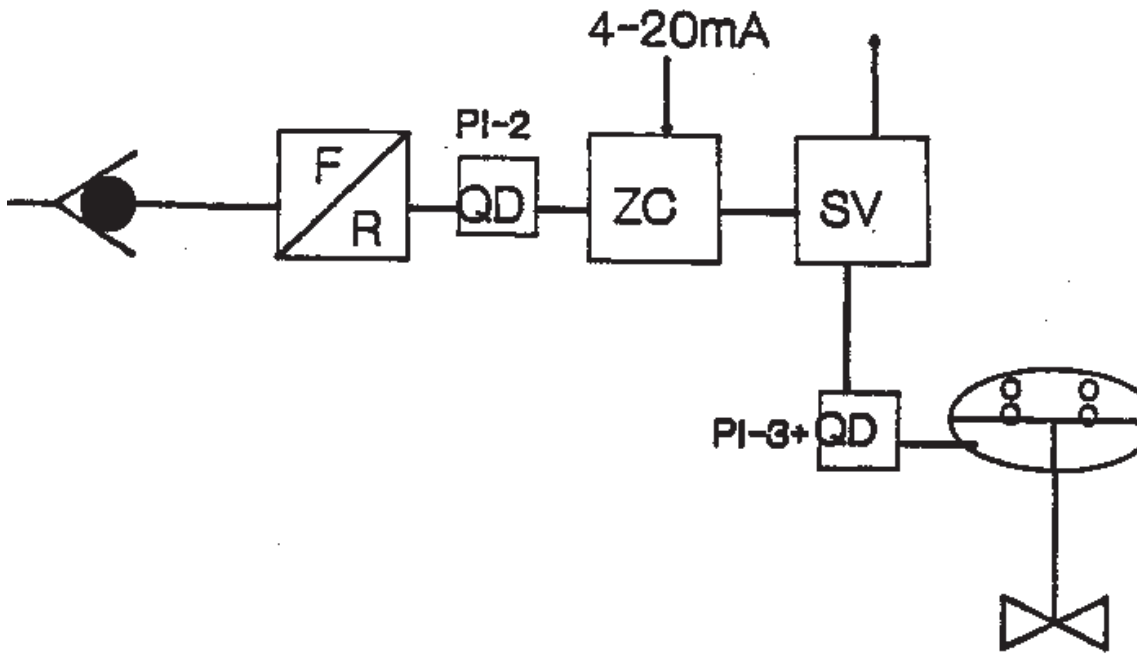

FIGURE EE

CD - 420
CD - 421

ENCLOSURE 4: QUICK DISCONNECT RELATIVE LOCATIONS (Continued)

NOTE: FOR SYMBOL KEY REFER TO ENCLOSURE 4 PAGES 1 AND 2

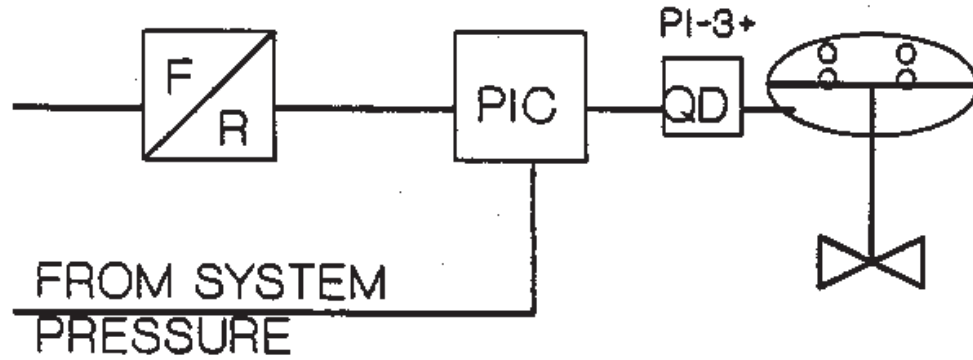

FIGURE FF

CF - 2864

ENCLOSURE 4: QUICK DISCONNECT RELATIVE LOCATIONS (Continued)

NOTE: FOR SYMBOL KEY REFER TO ENCLOSURE 4 PAGES 1 AND 2

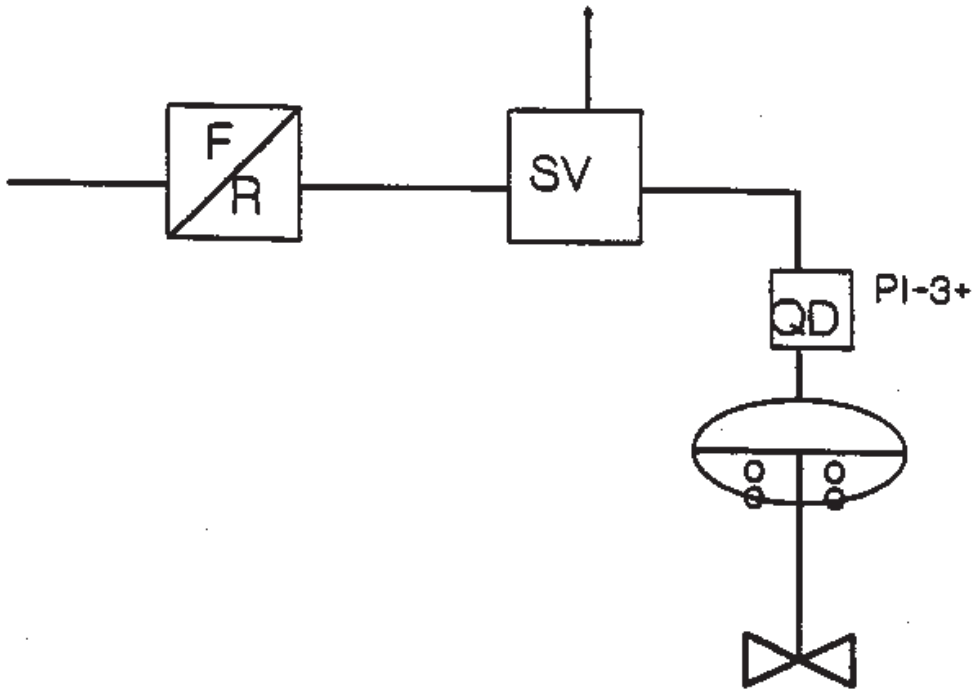

FIGURE GG

AS - 958	ES - 341	MS - 266	TD - 4981
AS - 2035	ES - 409	PW - 225B	TD - 4982
AS - 2073	ES - 411	RC - 222	WG - 1819
AS - 2076	ES - 413	RC - 225A	WG - 1820
AS - 2597	ES - 415	RC - 2548	
AS - 3748	ES - 417	TD - 2368	
ES - 249	FO - 1503	TD - 2369	
ES - 252	GS - 2167	TD - 2382	
ES - 308	MS - 138	TD - 2383	

ENCLOSURE 4: QUICK DISCONNECT RELATIVE LOCATIONS (Continued)

NOTE: FOR SYMBOL KEY REFER TO ENCLOSURE 4 PAGES 1 AND 2

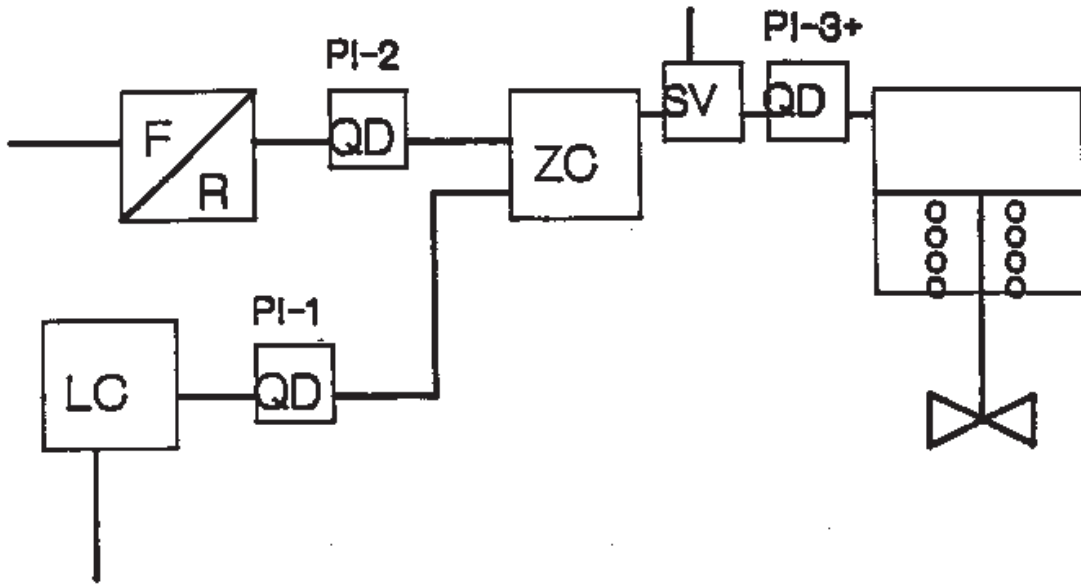

FIGURE NM

HD - 300B
HD - 331B

ENCLOSURE 5: SIGNOFF SHEET

<u>SECTION/STEP</u>	<u>DESCRIPTION</u>	<u>INITIAL/DATE</u>	<u>INITIAL/DATE</u>
(SO) 5.1.1	Obtained Shift Supervisor's permission. Shift Supervisor's name	____/____	____/____
(SO) 5.1.2	Notified Shift Supervisor of affected items.	____/____	____/____
(SO) 5.1.3	Obtained RWP, if applicable.	____/____	____/____
(SO) 5.1.4	Notified Quality Control, if applicable.	____/____	____/____
(SO) 5.1.5	Established communications as necessary.	____/____	____/____
(SO) 5.1.6	User of procedure has read and understands contents.	____/____	____/____
(SO) 5.2.1	Verified valve being worked on is isolated and tagged in accordance with DB-OP-00015. <u>AND</u> tubing is depressurized.	____/____	____/____
(SO) 5.2.2	RC Supervisor notified if applicable.	____/____	____/____
(SO) 8.1.2	Quick disconnect location determined per Enclosures.	____/____	____/____
(SO) 8.1.3	Ensured quick disconnect locations will have adequate support.	____/____	____/____
(SO) 8.1.4	Maximum span criteria have been met if applicable.	____/____	____/____
(SO) 8.1.5	Quick disconnect locations will be accessible for test tubing.	____/____	____/____
(SO) 8.2.1	Quick disconnects installed.	____/____	____/____
(SO) 8.2.2	Coupler protector is installed and secured.	____/____	____/____
(SO) 8.3.2	No visible leaks found during leak check.	____/____	____/____

Enclosure 5
Page 1 of 3

ENCLOSURE 5: SIGNOFF SHEET (Continued)

<u>SECTION/STEP</u>	<u>DESCRIPTION</u>	<u>INITIAL/DATE</u>	<u>INITIAL/DATE</u>
(IV) 8.3.3.1	Maximum span criteria has been met. N/A if Areas 1, 2, 3, 4 or 5.	____/____	____/____
(IV) 8.3.3.2	Quick disconnects accessible for connection and disconnection of test tubing.	____/____	____/____
(IV) 8.3.3.3	The relative location of the quick disconnects match the appropriate figure in Enclosure 4.	____/____	____/____
(IV) 8.3.3.4	Quick disconnect protective caps are installed and captured.	____/____	____/____
(SO) 8.4.1	Valve has been stroked to verify proper operation.	____/____	
(SO) 8.4.2	Notified Shift Supervisor that quick disconnects have been installed and that valve may be returned to service.	____/____	

ACCEPTANCE CRITERIA

1. For air operated valves in Areas 6, 7, 8 or 9, the quick disconnects installed do not exceed the maximum span criteria listed in Enclosure 1.
2. The quick disconnects installed are accessible for the connection and disconnection of test tubing.
3. The relative location of the quick disconnects are installed in accordance with the appropriate figure in Enclosure 4.
4. When Leak-Tek (or equivalent) is applied, no visible air leakage is observed from the valve tubing or tubing connections.
5. The protective caps of the quick disconnects are installed and captured to prevent their loss.

48

DB-MI-09071
Revision 00

ENCLOSURE 5: SIGNOFF SHEET (Continued)

INSTRUMENT NUMBER _____

Comments: _____

This procedure was worked in conjunction with MWO Number _____

Performed By: _____ / _____
Signature Date

Acceptance Criteria have been met _____ / _____
Signature Date

Reviewed By: _____ / _____
I&C Supervisor Date

END

Enclosure 5
Page 3 of 3

APPENDIX C

AOV ACQUISITION SYSTEM CASE HISTORIES

C.1 INTRODUCTION

The case histories included here are from a number of sources, and although the text may have been edited, the conclusions or results are solely those of the contributors and have not been verified by the authors.

C.2 SUPPLY PROBLEMS

If a valve is having problems meeting stroke times or has control problems (if fast system response is a requirement), the volume of supply air should be reviewed.

Case 1 - Restricted Air Supply

Figure C-1 presents both the supply pressure and actuator pressure plotted against time. This example is a double-acting piston actuator

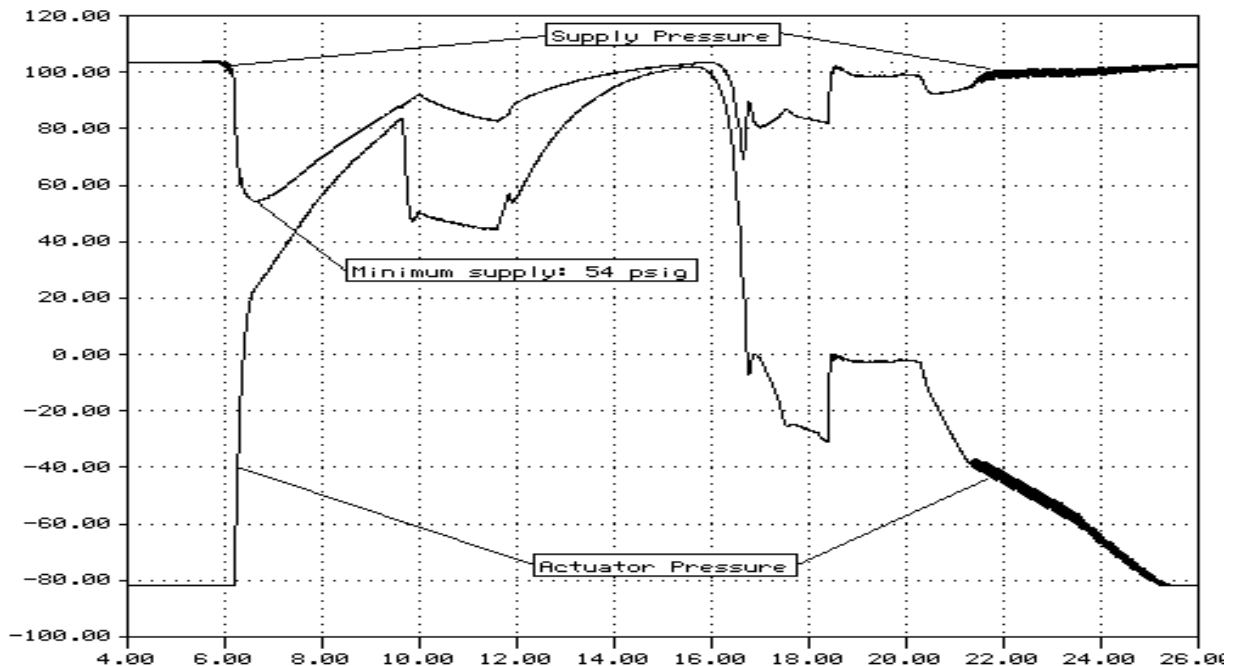

Figure C-1
Before—Small Supply Tubing

The following are possible indications of restricted air supply:

- The air supply pressure drops from 103 psig to 54 psig during the initial demand for air.
- The air supply pressure follows the same contour as the actuator pressure during most of the stroke.
- While the valve is controlling, there is a significant supply air pressure drop. During the time periods 10 through 12 seconds and 18 through 20 seconds, the valve is being controlled. There should be very little pressure drop in the supply air when the valve is in a normal control mode.

This particular valve had a 1/4-inch supply line leading to the positioner. This line was replaced with a 3/8-inch line and Figure C-2 shows the result.

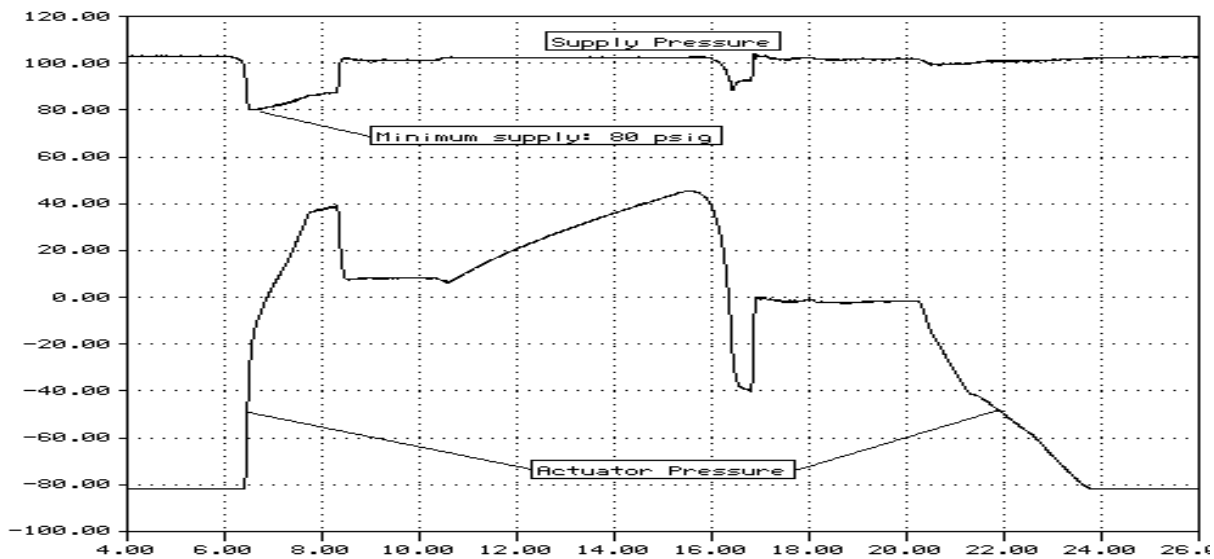

Figure C-2
After—Larger Supply Tubing

As can be seen in Figure C-2, the pressure drop during the initial demand is only a little over 20 psi, and during most of the stroke, the supply pressure is relatively constant. It is only during the high demand times that it drops.

Figure C-3 shows that there was almost a two-second improvement in the initial opening stroke due to this change.

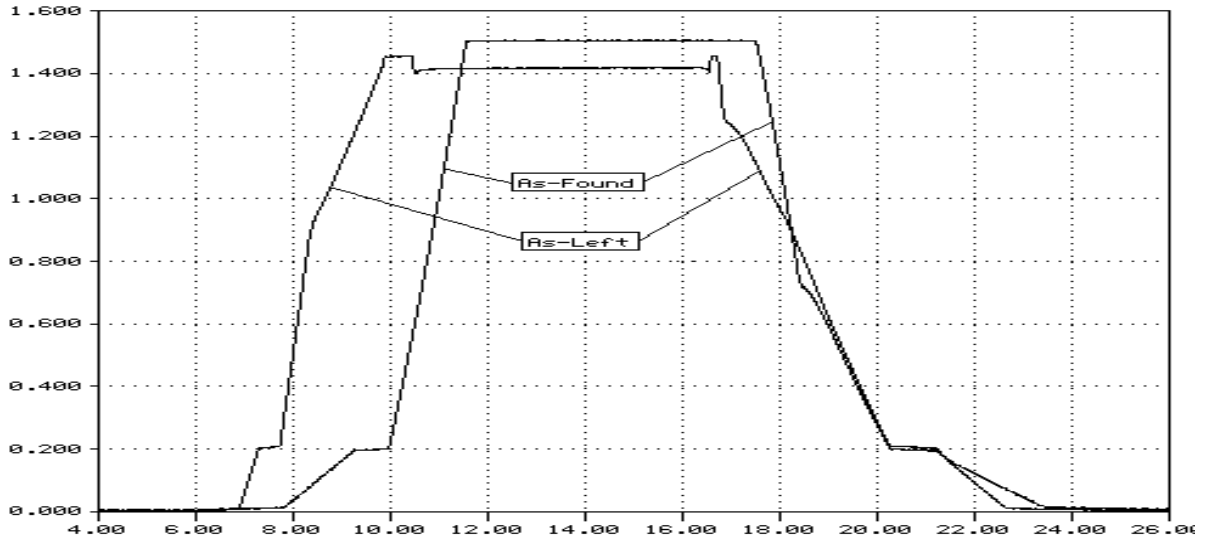

Figure C-3
Results of Change

It is prudent to remember that if there is not a problem with valve stroke time or normal valve control, even though some of the supply problem indicators are present, there might not be a problem.

Case 2 - Restricted Air Supply

This case is a good example of pressure drop across 70 to 100 feet of 5/16-inch tubing, even though there is a large accumulator just upstream of the start of the tubing. The supply air pressure is being measured just upstream of the solenoid-operated valve (SOV), which is controlling the valve. As Figure C-4 shows, the supply pressure is being reduced to 15 and 17 psig from the original 100 psig.

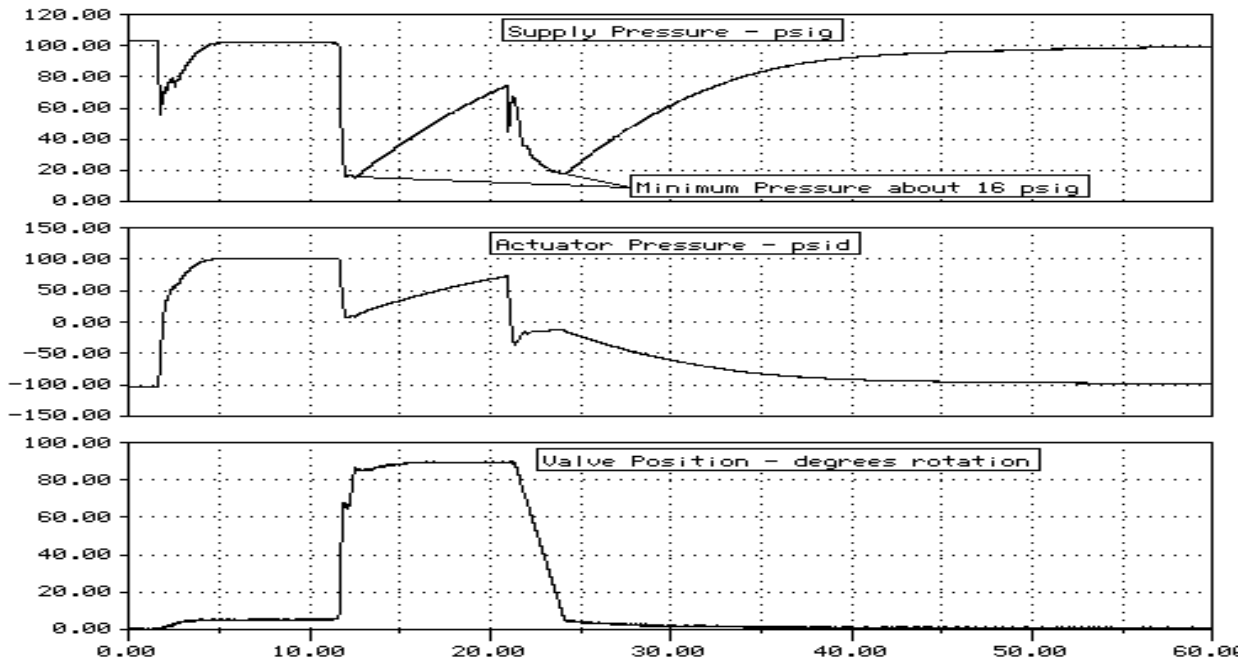

Figure C-4
 Time in Seconds
 48-Inch Butterfly Valve with 5/16-Inch Tubing—70 Feet plus Long

C.3 TRANSDUCER PROBLEMS

Case 1 - Defective I/P - Relays and Coil

Fisher 546 The transducer was not outputting the correct pressure for the input signal. Upon disassembly and inspection, the relay and coil were found to be defective, requiring immediate maintenance. See Figure C-5.

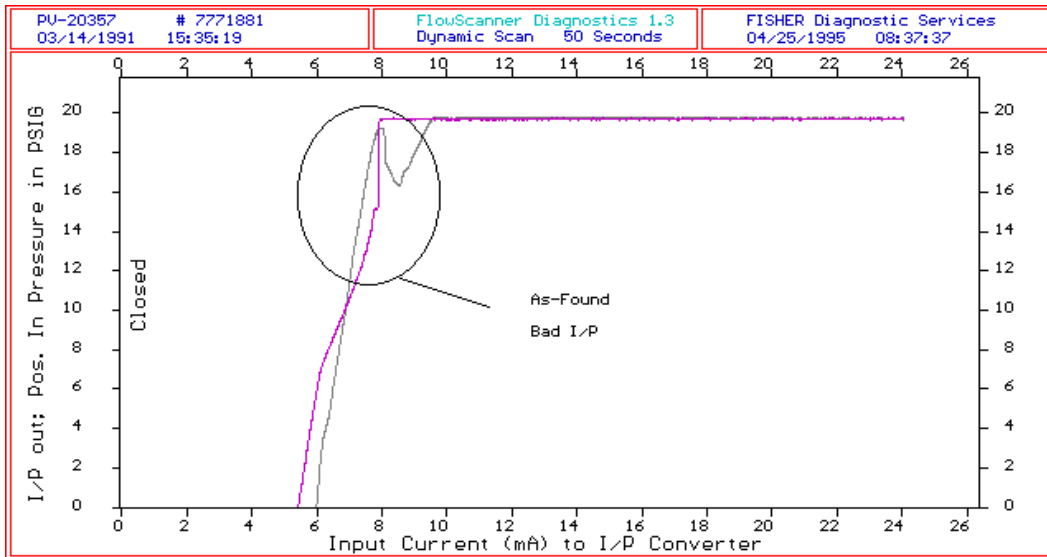

Figure C-5
As-Found

After repair - See Figure C-6. There is still a slight calibration adjustment to be made, but the instrument is clearly operating as intended (4-20 mA input/3-15 psi output). Note that there is a slight difference between the increasing and decreasing signal at 4 mA due to hysteresis. Also note that this particular model of I/P continues to have a linear output pressure below 4 mA.

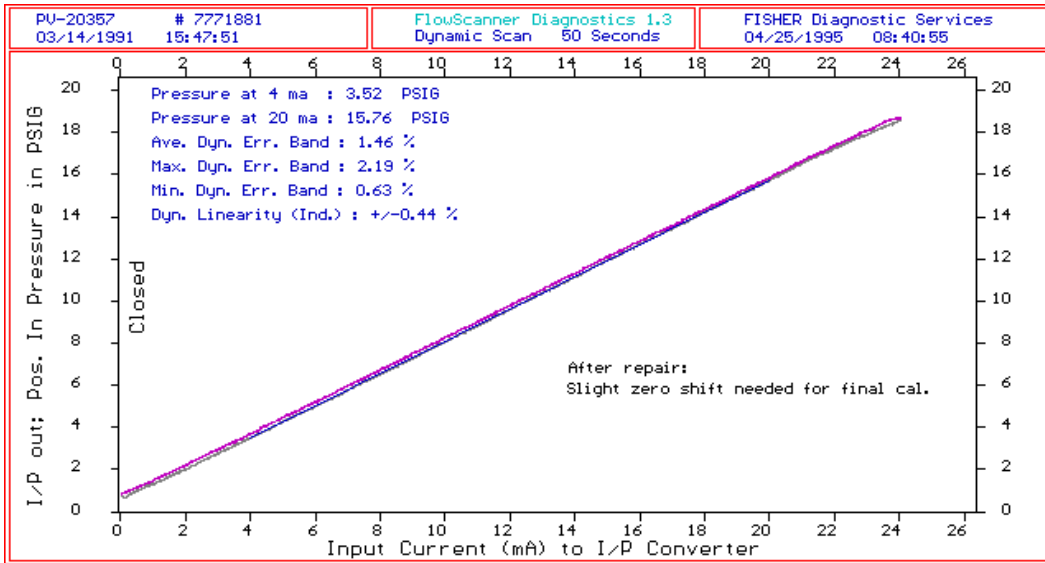

Figure C-6
After Repair

Case 2 - I/P Leak

Based on poor mid-range performance (see Figure C-7), this facility was prepared to custom characterize a valve cage in order to obtain a particular flow characteristic. A single dynamic test (see Figure C-8) confirmed that the problem was not with the valve but rather with the I/P as shown below.

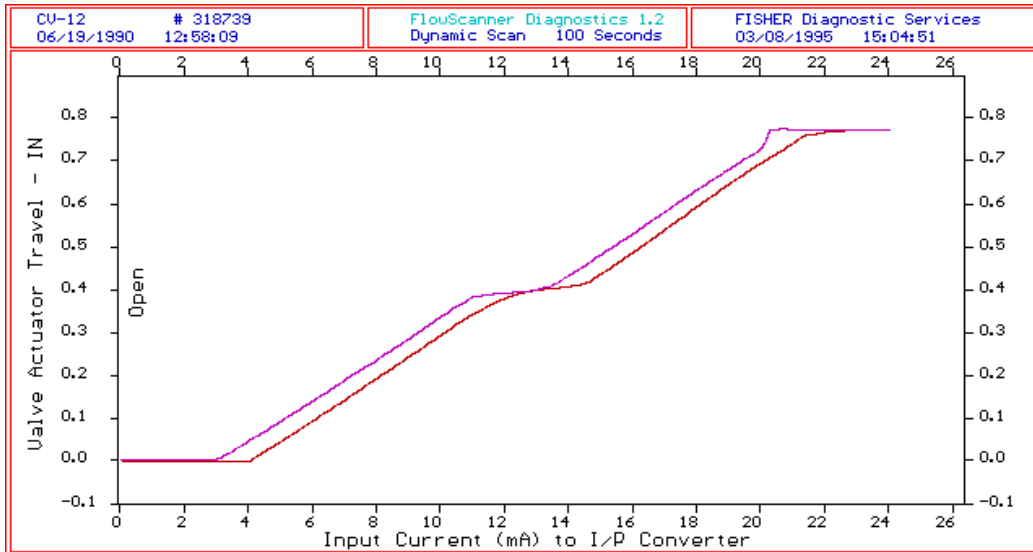

Figure C-7
Overall Calibration

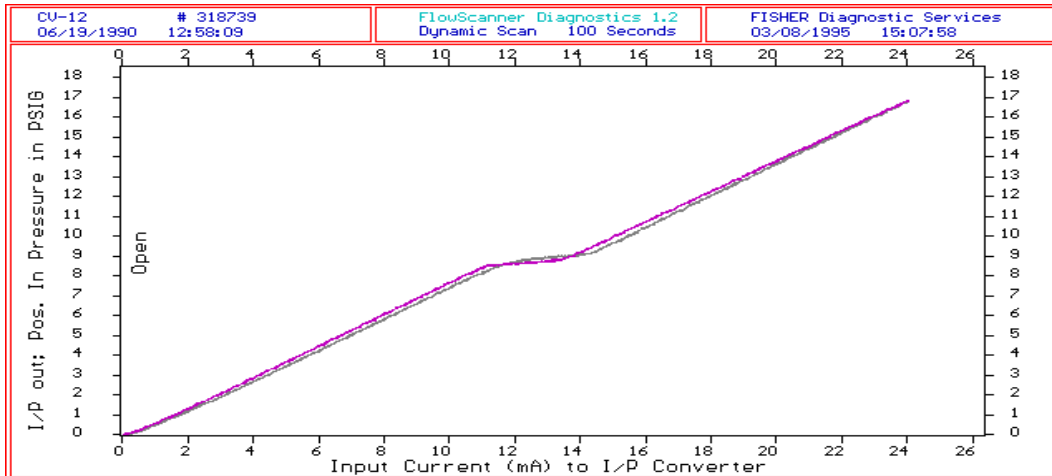

Figure C-8
I/P Calibration

Case 3 - I/P Leak

Although the input changes from 11 to 14 mA, the output pressure remains at 9 psi (see Figure C-9). This condition occurs at mid-range and is the source of the complaint noted against the valve. On an increasing signal, the pressure recovers and remains linear. This is a “classic” indication of a leak. Because the pressure was measured upstream of the positioner, the source of the leak could be internal to the positioner, internal to the I/P, in the tubing connection, or in the flow scanner test connection. It is incumbent upon the operator to identify the source.

For this particular illustration, the source was in the tubing fitting connection between the I/P and the positioner. A bench check of the I/P or the positioner could not have identified and isolated this problem because it was inherent to the *in situ* installation.

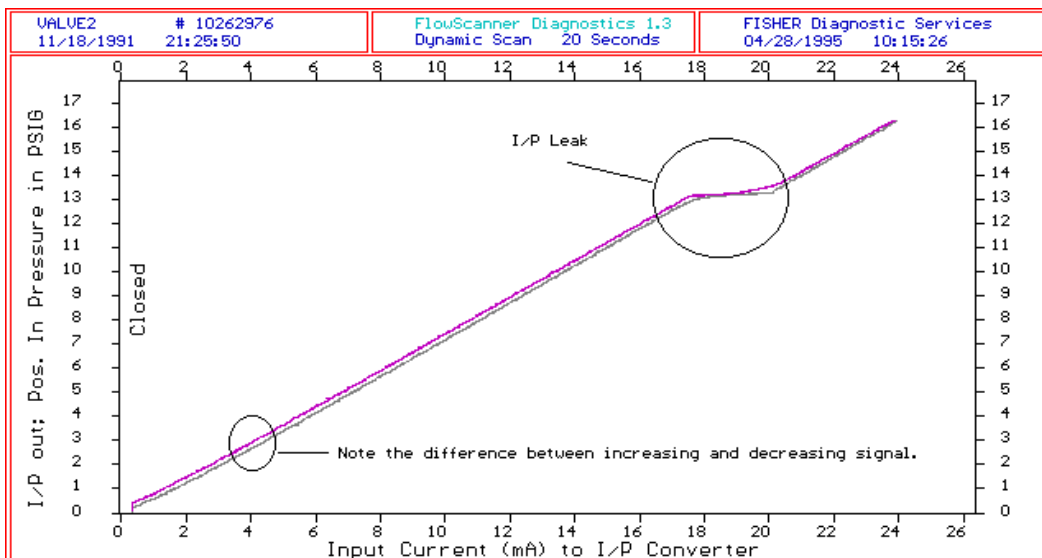

Figure C-9
I/P Calibration

C.4 POSITIONER PROBLEMS

Case 1 - Positioner Bellows

Figure C-10 shows the positioner performance (pressure versus travel). A Fisher 546 I/P has a 6-30 psig output pressure feeding a 3582 positioner with a 3-15 psig bellows. The positioner bellows was found to be severely deformed. The valve position is distorted and is not uniform for any positioner pressure over 15 psig. Compare these results to the response for pressures less than 15 psig.

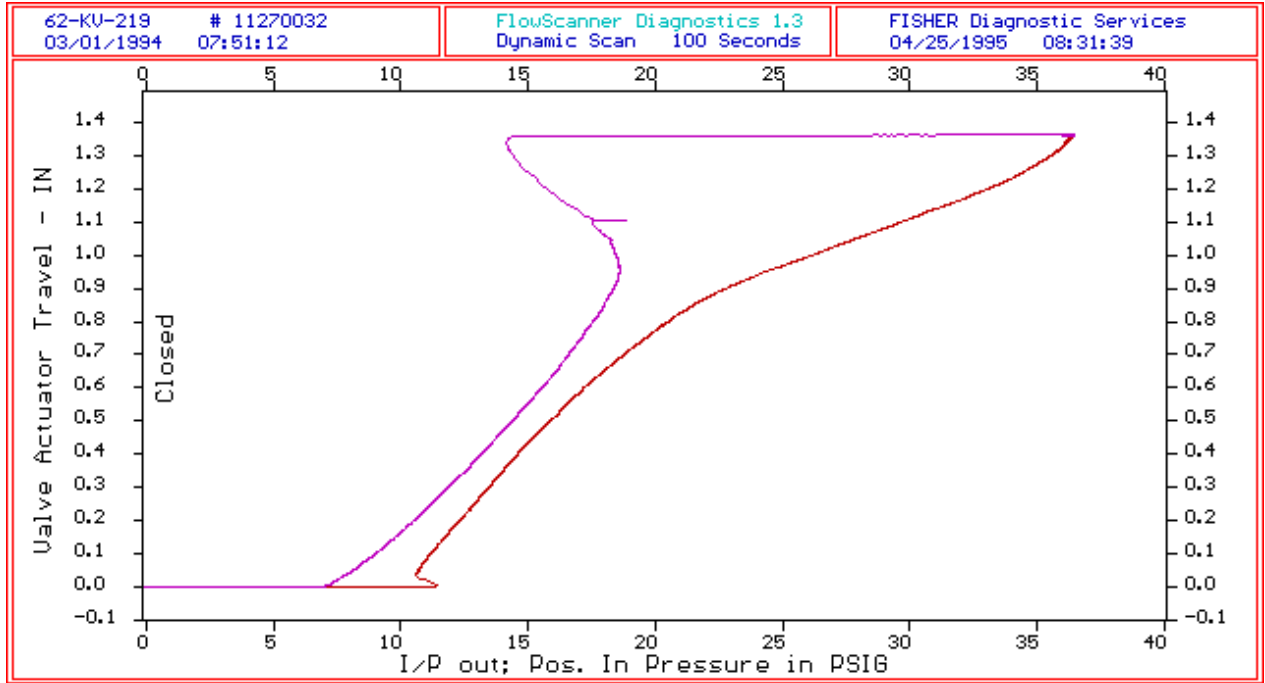

Figure C-10
Positioner Bellows

Case 2 - Stability Problem, Double Acting Cylinder

The valve is a globe valve with a double-acting cylinder actuator. The reported problem was unstable control during plant operation. The Data Acquisition System testing was done using 150-second increasing and decreasing ramps, with a 10 to 50 milliamperere control signal input into the I/P. See Figure C-11.

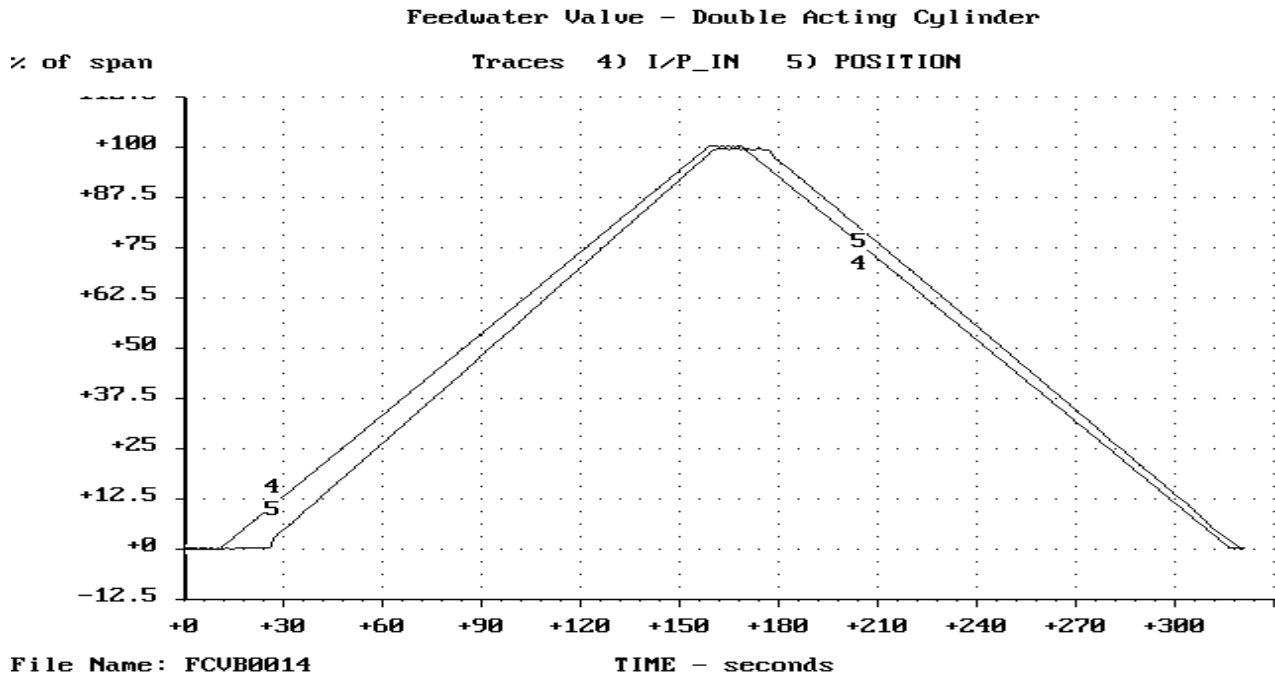

Figure C-11
Feedwater Valve—Double-Acting Cylinder
Percent of Span versus Time

Figure C-12 shows the differential actuator pressure (Trace 3) that was obtained by measuring the upper and lower cylinder pressures with a differential pressure transducer. As can be seen the pressure ranges are about ± 10 psid (approximately plus 10 psi when the valve is opening and minus 10 psi when it is closing). Note that when the valve is opening, the lower cylinder is reading 10 psig, which means the upper cylinder must be reading zero pressure. When the valve is closing, the lower cylinder is reading zero, which means that the upper cylinder must be reading 10 psig. So at any time during normal controlling operation, the largest cushion of air is 10 psi.

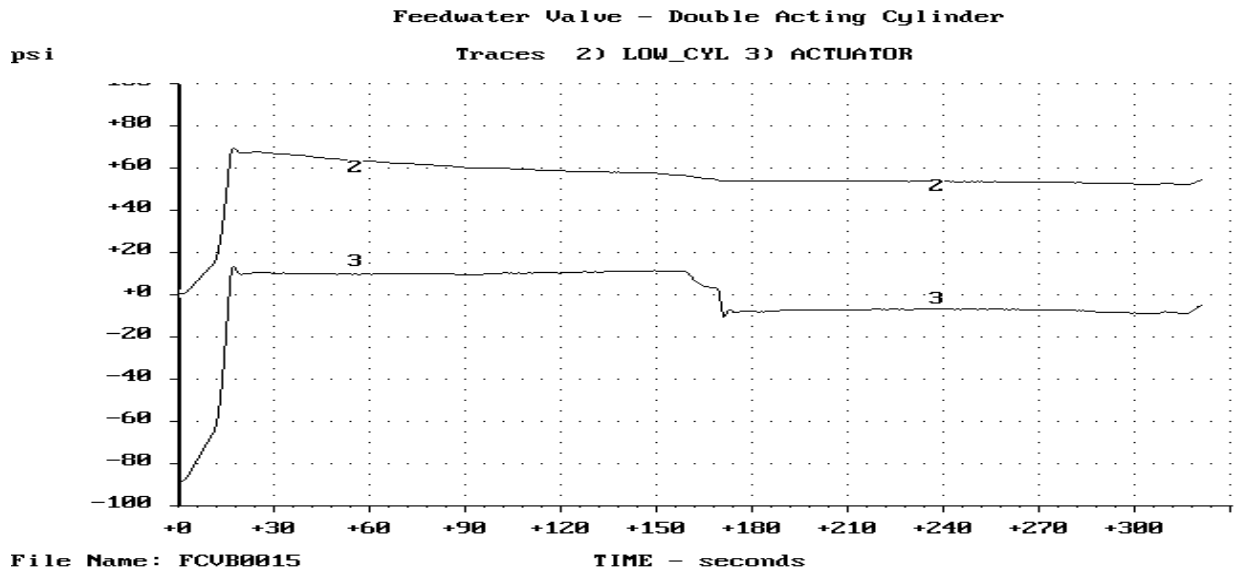

Figure C-13
Feedwater Valve—Double-Acting Cylinder—PSI versus Time

Increasing the nominal pressure from an average of 0 to an average of 60 will definitely increase the stability of the valve. It is similar to installing a stronger spring or a much stiffer shock absorber. Increasing the nominal actuator pressure away from zero prevents the actuator from having to completely dump one side of the actuator and add pressure to the other every time the valve direction is changed. Now the actuator only has to add or dump one side of the actuator to move the valve. Figure C-14 shows the improvement in dynamic error, from 9.4% to 1.8%, more than 5 times better in controllability.

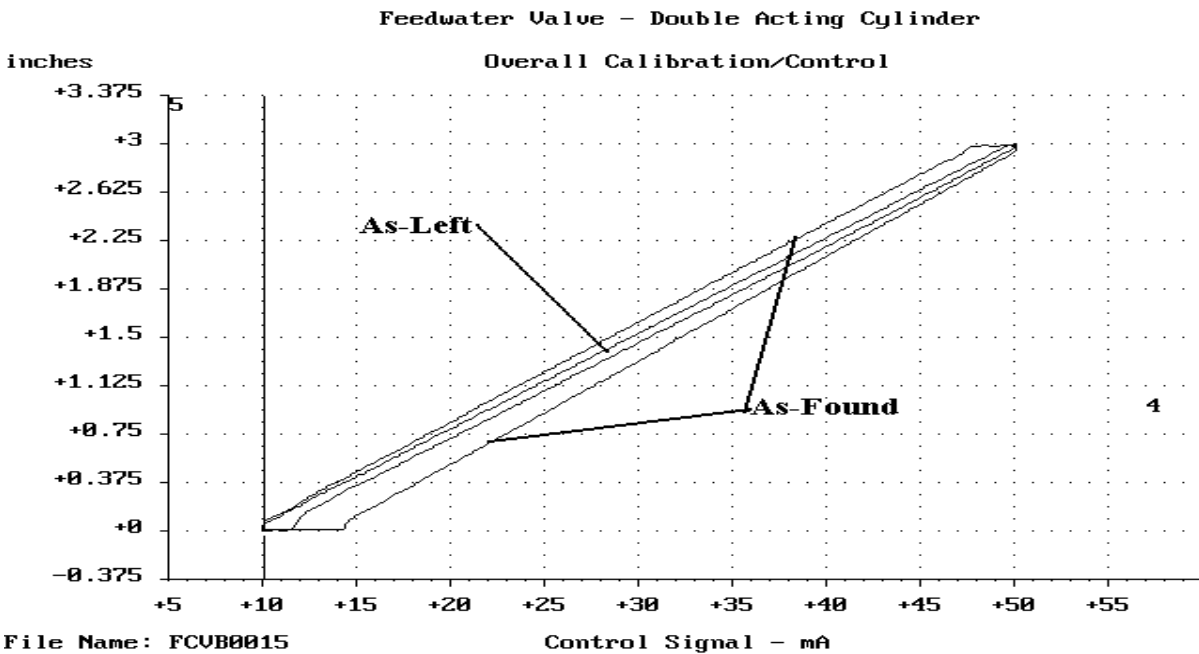

Figure C-14
Feedwater Valve—Double-Acting Cylinder —Overall Calibration/Control

Case 3 - Air Leak, Internal to the Positioner

Figure C-15 is typical of a normal regulated supply pressure (Trace 2) with a high volume requirement. That is, this valve has a 280-square-inch, spring-return actuator that tends to drag down the air supply whenever it moves. Note that when the valve is opening the supply pressure drops, but it stays constant as the actuator is demanding a large volume of air to build up the air pressure. On the down stroke, there is a slight, but again constant, reduction in air pressure as the positioner controls the volume of air in and out of the actuator to get the valve stroke to follow the control signal.

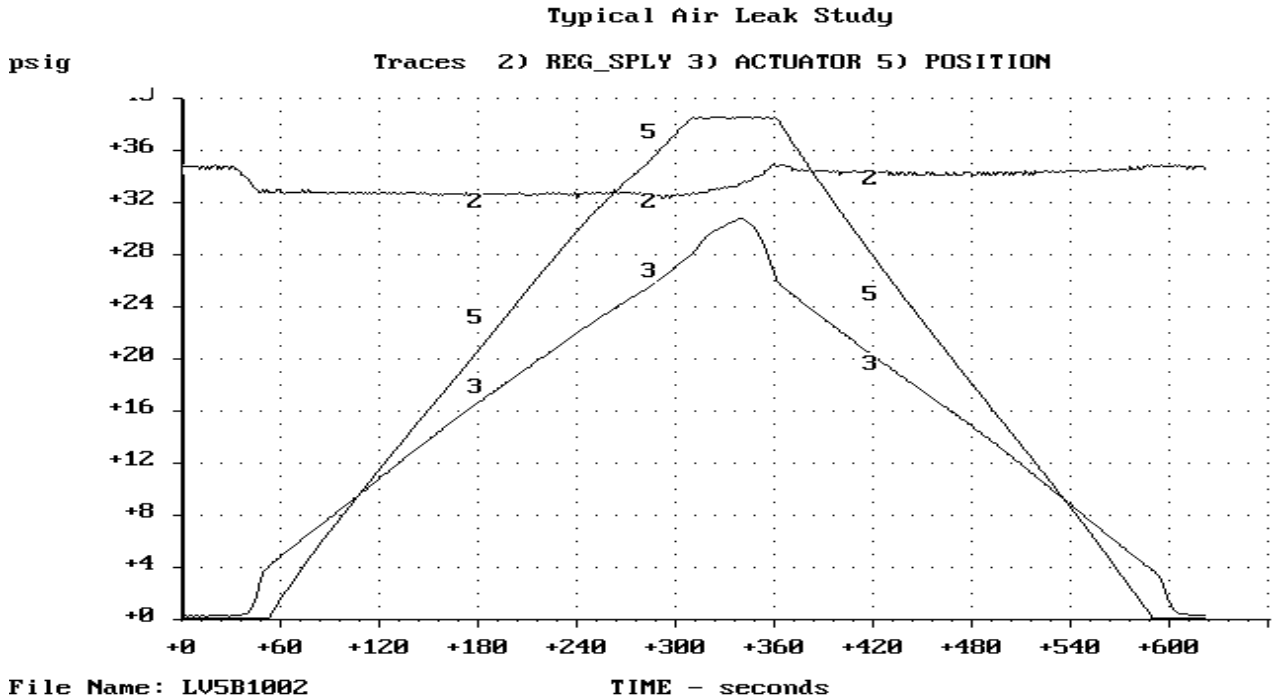

Figure C-15
Example of No Leak

In Figure C-16, note that the regulated supply pressure is low when the actuator pressure is low and reaches the highest values when the actuator pressure is at it highest. The lower regulated supply pressure must be due to either a demand or a leak (or possibly both). Because it is demanding the most when there is no pressure in the actuator, the leak cannot be in the actuator. Because the leak is highest when the demand is lowest in the actuator, the leak must be in the positioner where the delta P is highest at this time and lowest when the actuator is pressurized.

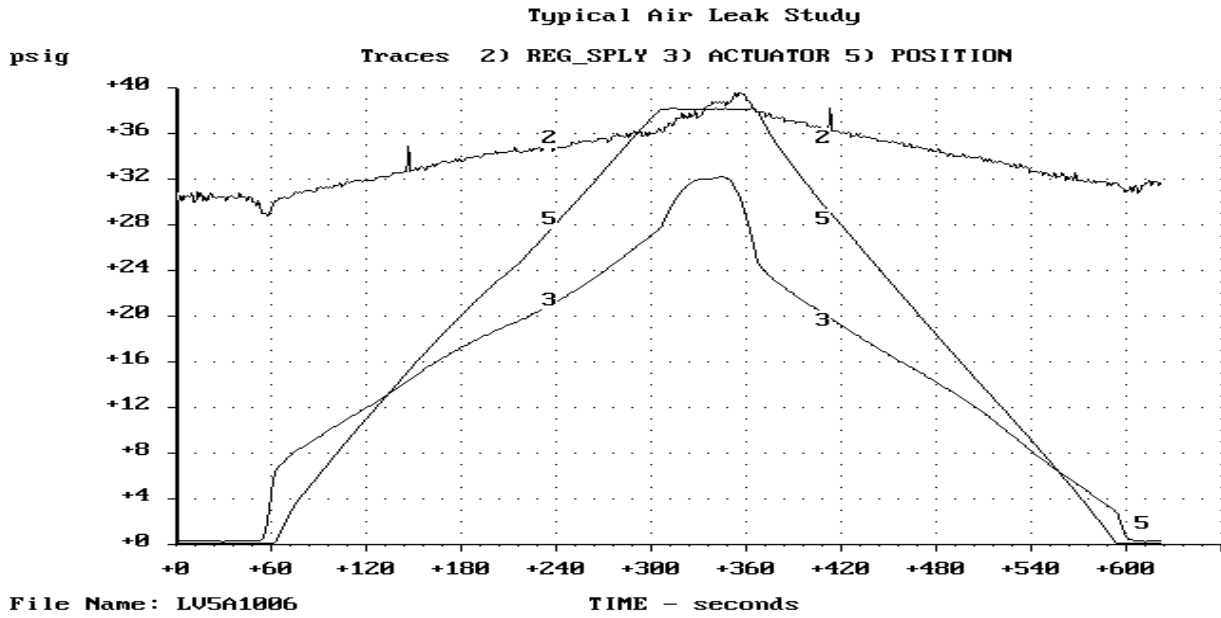

Figure C-16
Typical Air Leak Study—PSIG versus Time

When the Actuator Pressure (X axis) is plotted versus the Regulated Supply Pressure (See Figure C-17), it can be seen that there is a direct correlation; the greatest demand occurs at the lowest actuator pressure.

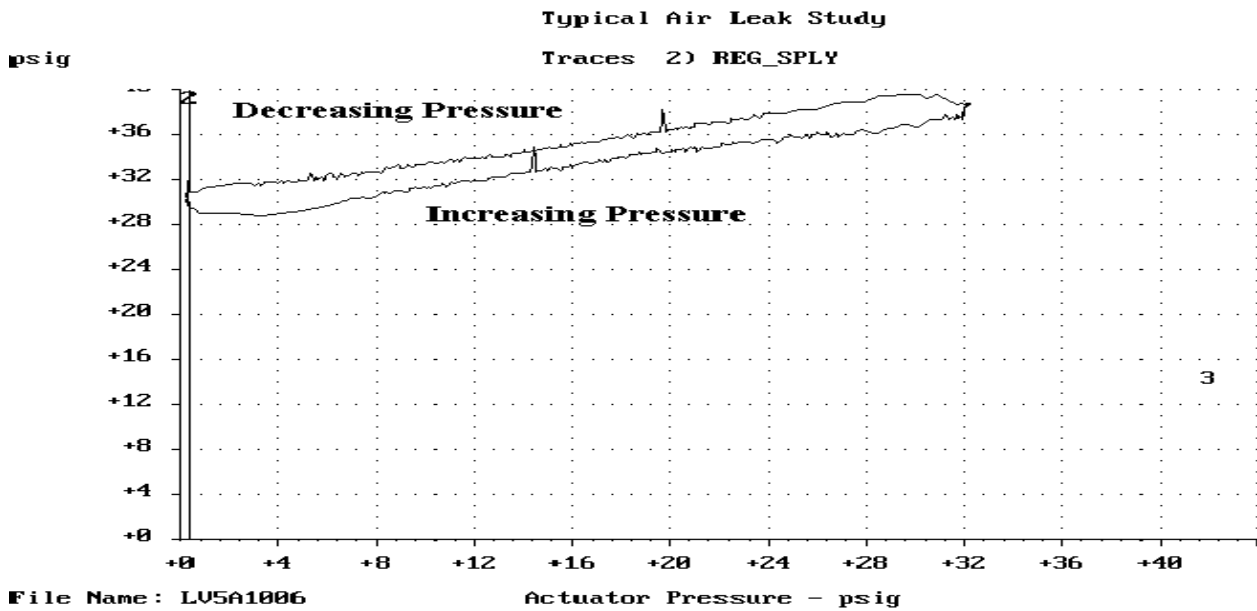

Figure C-17
Typical Air Leak Study—PSIG versus Actuator Pressure

Case 4 - Air Leak Downstream of the Positioner

Figure C-18 illustrates the case where the demand is the greatest when the actuator pressure is the highest. The high actuator pressure would occur any place downstream of the positioner, from the tubing up to and including the actuator.

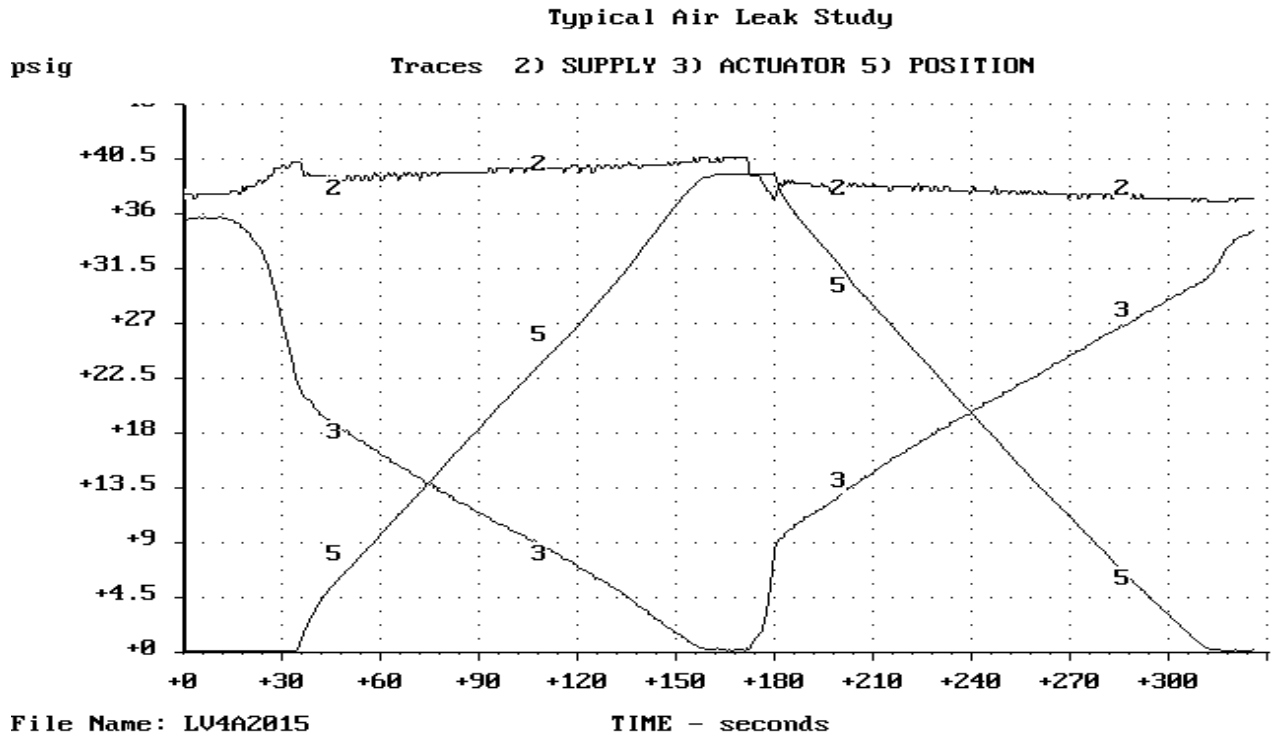

Figure C-18
Typical Air Leak Study—PSIG versus Time

Although not as dramatic as Figure C-17, there is a definite slope to the lines in Figure C-19, which decrease with increasing actuator pressure.

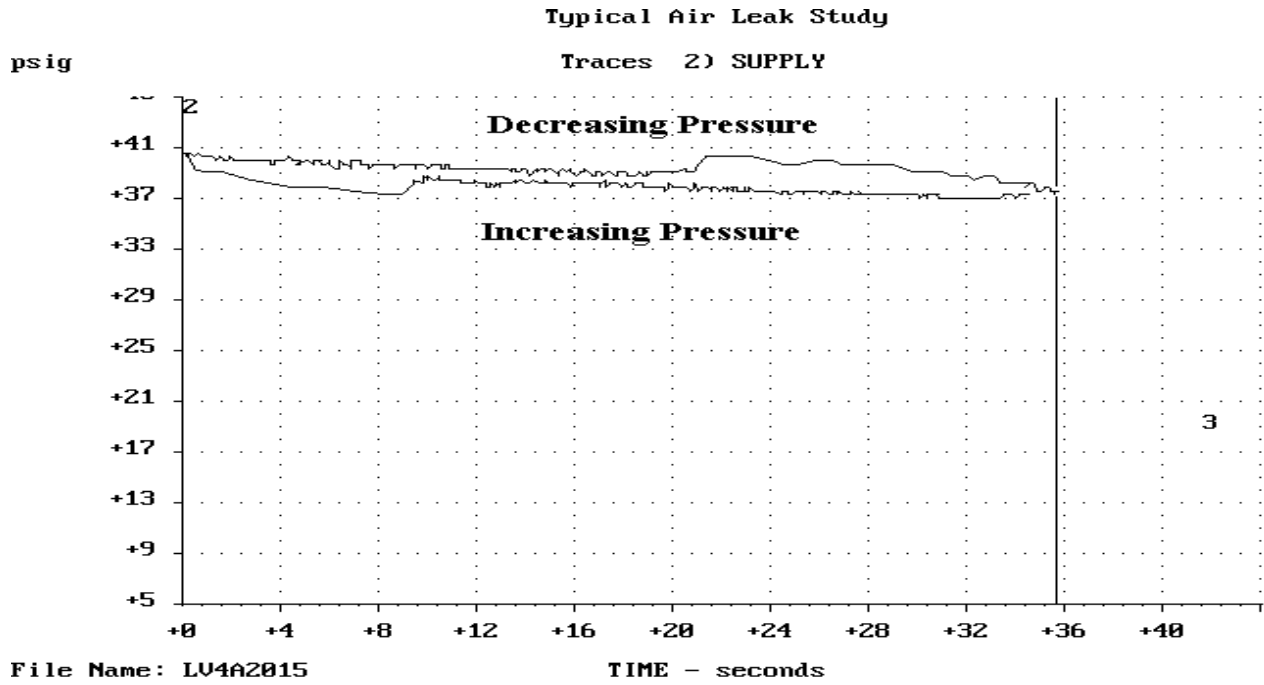

Figure C-19
Typical Air Leak Study
PSIG versus Time

C.5 VALVE PROBLEMS

Case 1 - Butterfly Valve—Sticking in its Seat

A 48-inch reactor building vent valve with a double-acting piston actuator appears to be sticking in its seat when it does not seem to start to move for almost 10 seconds and the actuator pressure completely transfers from one side of the cylinder to the other. See Figure C-20.

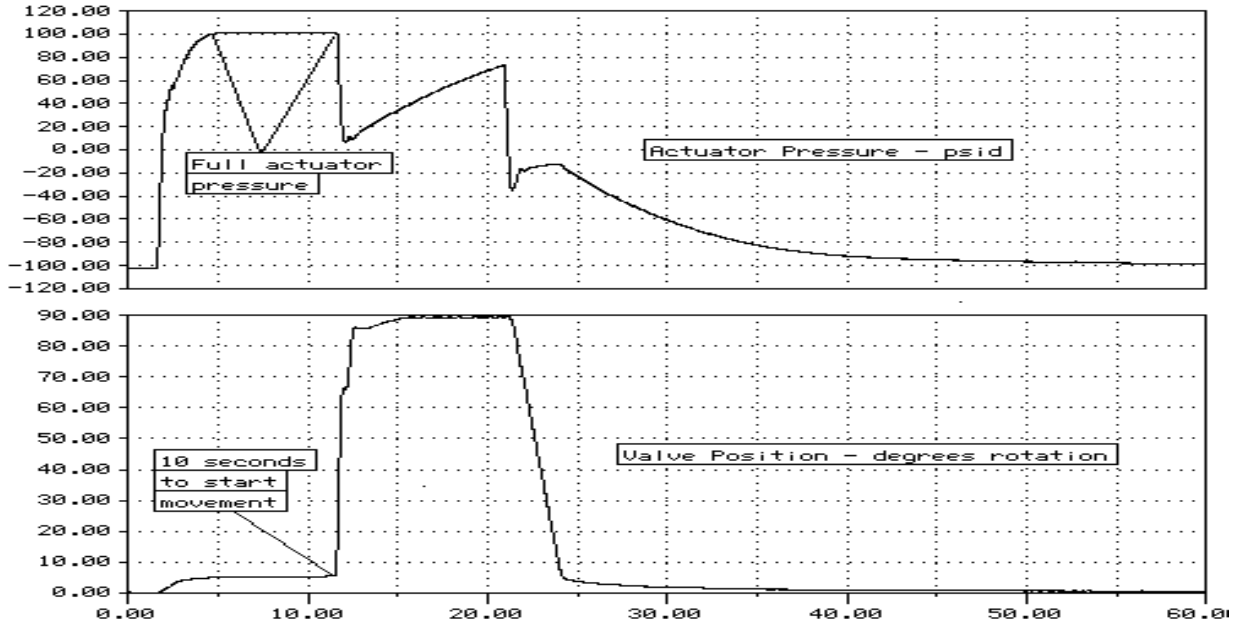

Figure C-20
Time in Seconds—48-Inch Butterfly Valve—Seat Problem?

Note how there is a full transfer of actuator pressure from a minus 100 psig (100 psig in the lower cylinder) to a positive 100 psig (100 psig in the upper cylinder) in about 3 seconds. Yet the valve does not “jump open” until 10 seconds after the start of the event. This initially might be considered a failure to open, especially when there does not appear to be any problem with the closing stroke.

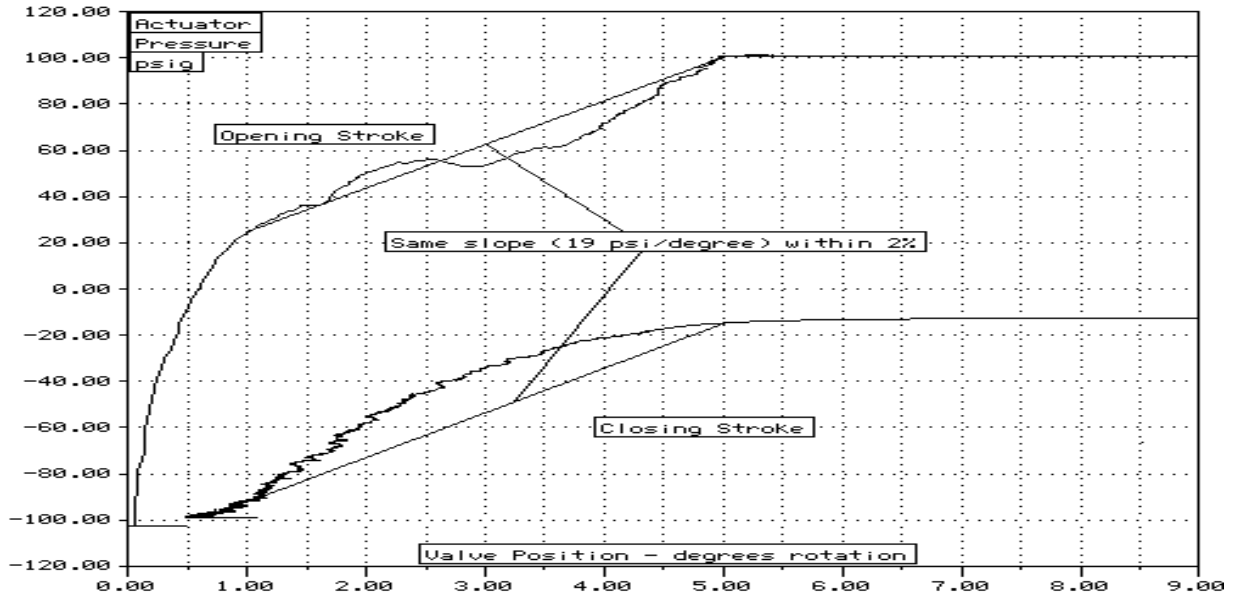

Figure C-21
Exploded View of Mechanical Properties

In reality the valve has just as much of a problem going back into the seat as it had coming out of the seat. When the change in pressure, the force required to move the valve, is looked at between 1 degree open and 5 degrees, it is the same within 2%. This indicates that it takes just as much force to get the disk out of its seat as it does to get it into the seat. Requiring all of the actuator pressure to both seat and unseat the valve is not an acceptable situation. It appears that the running loads are much lower, less than 20 psi. Possible causes are wrong seating material or size, or the travel stops are set to allow the valve disk to travel past the seat.

Case 2 - Galling/Cage

This figure is used to determine the valve/actuator forces as the valve is stroked from its fully closed-to-open position and then cycled. The pressure applied from the positioner to the actuator shows a distinct change for travel greater than an inch off the valve seat. Figure C-22 shows pronounced jerky binding, which was attributed to galling in the cage/plug. This was confirmed upon disassembly.

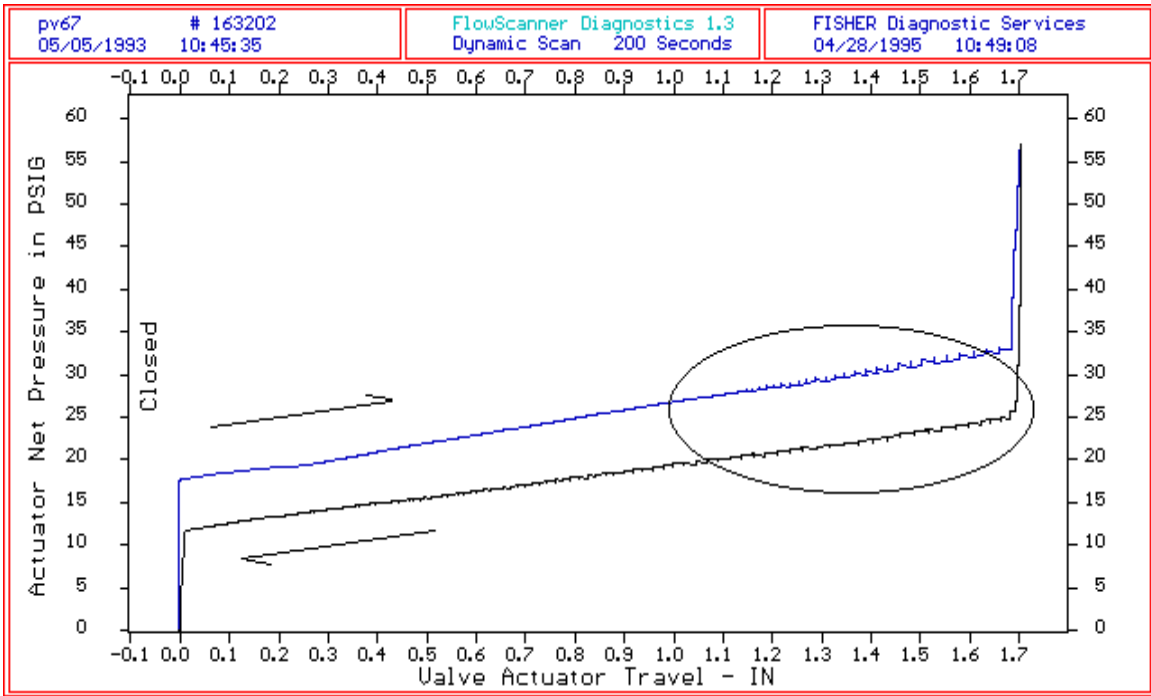

Figure C-22
Galling Cage Mechanical Properties

Case 3 - Excessive Coking - Plug Sticking in Cage

This figure is used to determine the valve/actuator forces as the valve is stroked. The pressure delivered to the actuator should be smooth and uniform between the increasing and decreasing signal. Figure C-23 clearly exhibits pronounced binding and excessive friction in the sliding/guiding surfaces. An additional 5 psig is required to overcome static friction at both ends of the valve stroke.

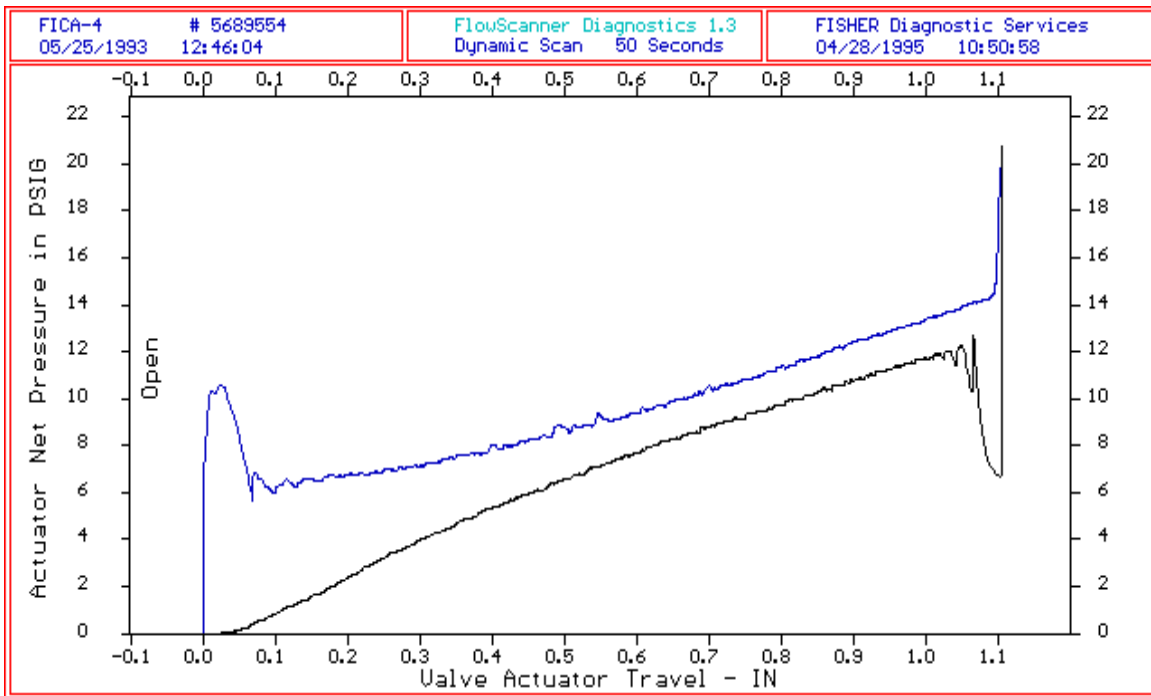

Figure C-23
Excessive Coking Mechanical Properties

The atypical signature for the assembly was attributed to the plug sticking in the cage. Upon disassembly, an excessive process residue buildup (coking) was readily apparent.

Case 4 - Severe Galling

Figure C-24 is an overlay of the before versus after repair results for a valve that was special ordered for a chemical plant. This graph is used to determine the valve/actuator forces as the valve is stroked. Acceptance testing specified that the valve be heated to the operating temperature of 575°F.

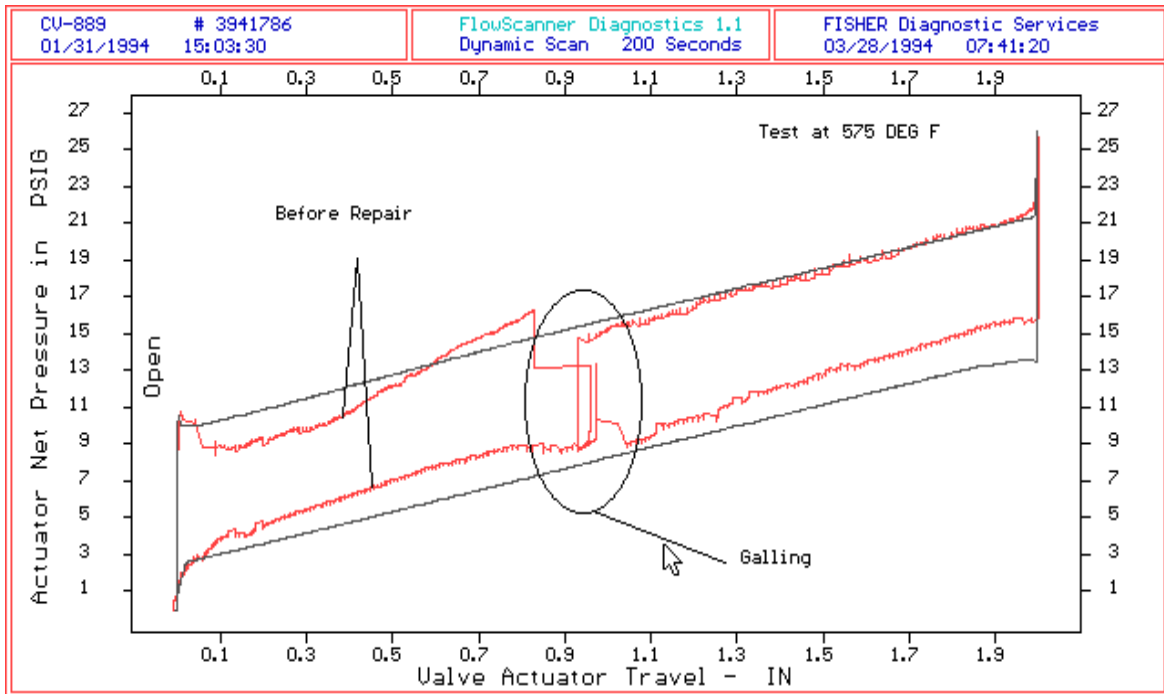

Figure C-24
Severe Galling Mechanical Properties

The test clearly shows severe binding occurring at mid-travel, which was attributed to galling of the packing box ring and stem. The valve was reassembled using replacement parts. The test was repeated without the extended bonnet with insulation. The retest shows acceptable (smooth) operation.

Case 5 - Packing Leak

The valve shown in Figure C-25 is a “classic” demonstration of a packing leak. This particular valve was in crude oil and has a 3/4-inch stem with composition packing. The valve would “spurt” as it was stroked and then stop.

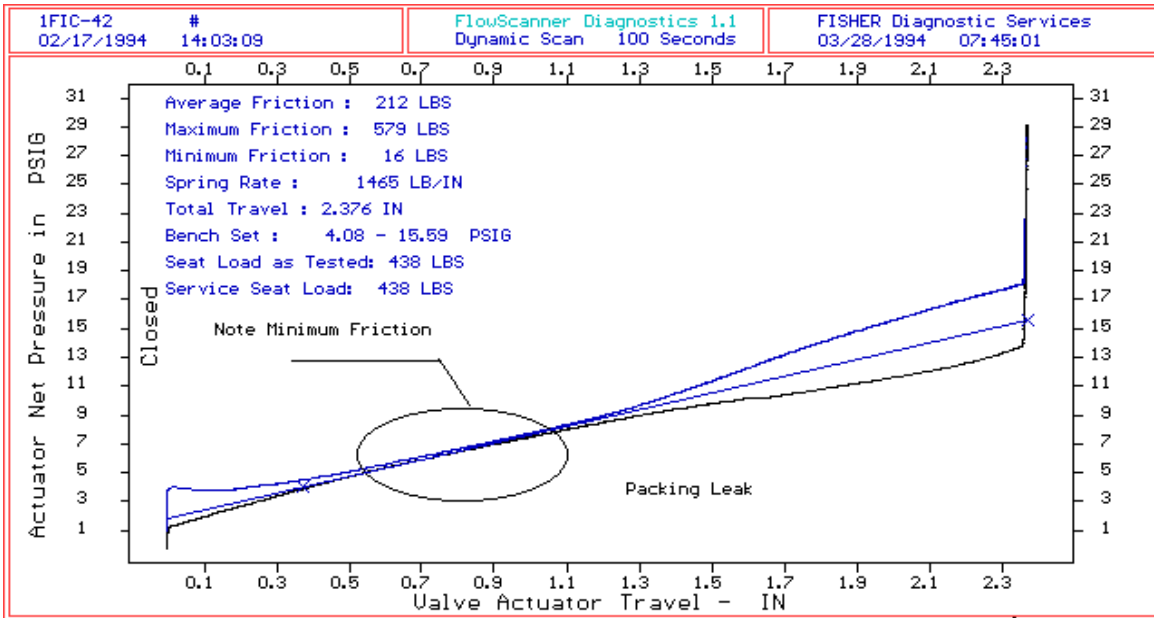

Figure C-25
Packing Leak Mechanical Properties

Note the variance in the friction band. The average force is 212 lbs. The minimum force of 16 lbs. occurs at 0.75 inches and is clearly insufficient for service conditions. This is probably due to localized wear on the stem from constant stroking in a limited range of valve travel (0.5 to 1.3 inches).

Case 6 - Expanded Seating Profile

Figure C-26 is an overlay showing the expanded seating profile for before and after repair. This graph is a “classic” demonstration of degraded plug/seat contact indicating severe wear that requires immediate maintenance. Compare the following points:

- Where the plug makes its initial contact into the seat
- The slope of the loading pressure developed for closure

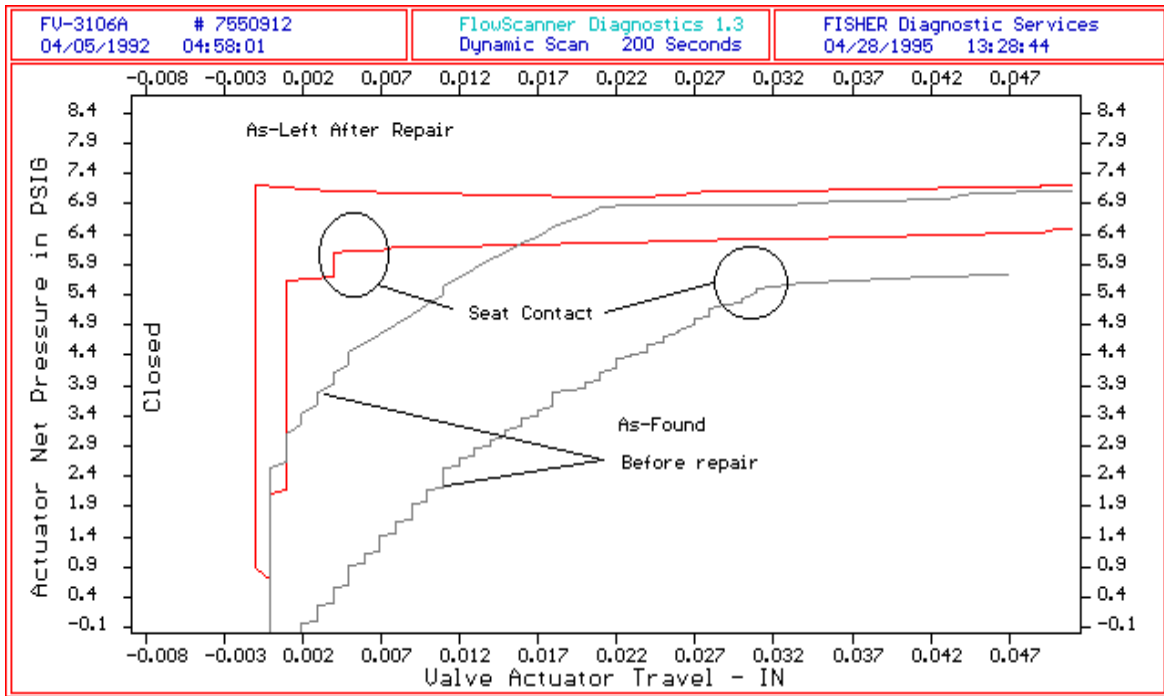

Figure C-26
Expanded Seating Profile Mechanical Properties

An overlay is a convenient method to detect, observe, and monitor overall degradation.

C.6 ACTUATOR PROBLEMS

Actuator Leak—Stem Seal

The valve shown in Figure C-27 does not have a positioner and is controlled by an I/P. The valve was oscillating in service. The graph indicates a distinct difference as the stem reverses direction. This defect was attributed to leakage in the O-ring seals in the stem bushing. The O-rings had degraded until they were hard. This resulted in only a partial seal being formed, which in turn caused fluctuations in the actuator output pressure.

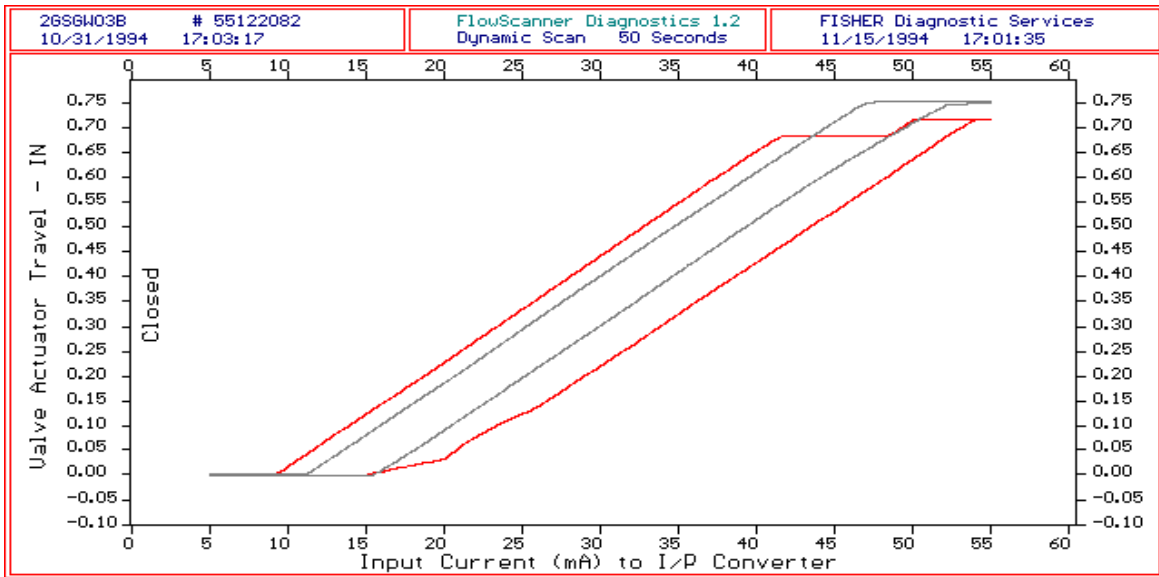

Figure C-27
Total Valve (Travel versus Signal)

The as-found and after-repair test results are overlaid for a comparison. The overall valve plot shows much reduced dynamic error band (DEB) after the actuator leak repair.

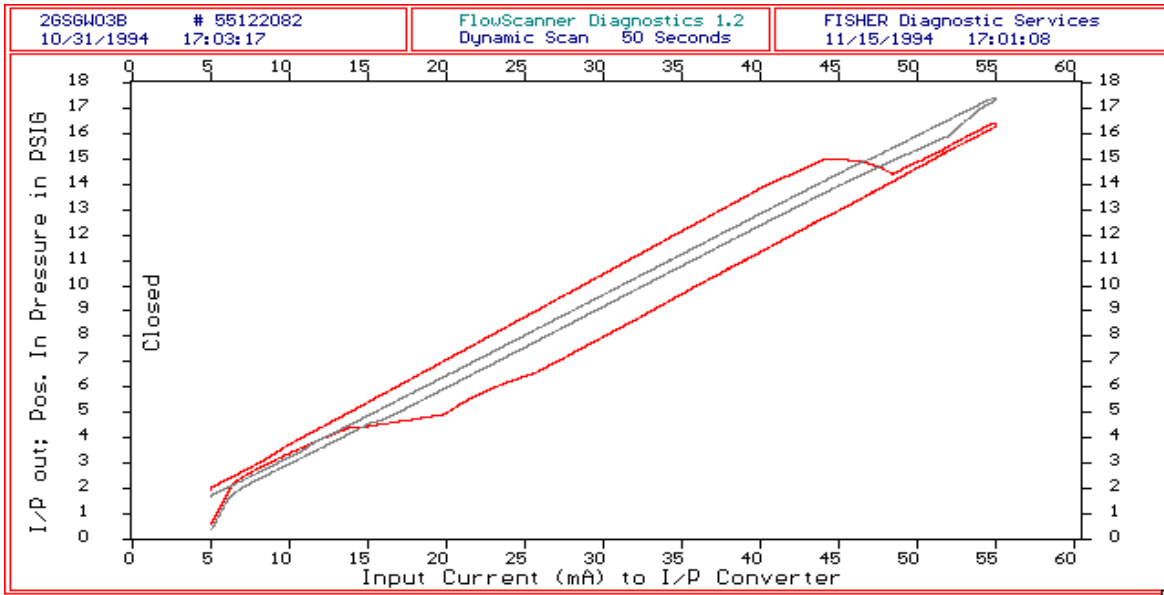

Figure C-28
I/P Calibration

The I/P plot also looks much tighter, because it is no longer providing the increased air volume to leak out the stem.

C.7 MISCELLANEOUS PROBLEMS

Pilot-Operated SOV

The following testing was completed with an ASCO pilot-operated solenoid-operated valve (SOV), model number 8344. This SOV is usually used to operate double-acting actuators where larger volumes of air are needed for large actuators or quick movement. Internally, there is a pilot SOV that distributes air pressure to either one end or the other end of a spool piece, which in turn directs air pressure to one end of the actuator while venting the other. As stated in the ASCO literature, there must be a minimum of 15 psig supplied to the SOV and all the ports must be full ported, no restrictions. The reason for these requirements is to ensure that the spool piece travels the approximate 1/2 inch to go from one end of its travel to the other. While the spool piece is moving from one end to the other or if it does not travel all the way, all of the ports are open to the exhaust port which is capable of venting everything if the supply lines are not properly sized.

The purpose of this case study is to point out that there is a clear indicator of the internal spool piece's movement. The purpose of the testing was to determine the effect of lower supply pressure and reduced air line sizes. The next three sets of figures present the results of tests that were conducted at three different air pressures: 100 psig, 60 psig, and 40 psig. All of the tests were run with the same reduced size tubing to determine the point at which the SOV would not operate properly.

Figure C-29 was run at 100 psig and the two plots show the de-energizing and energizing sequence. During the de-energizing sequence, the supply pressure and the lower cylinder pressure starts to drop off in about 0.025 seconds. During this period, the spool piece has started to move across and has opened up the exhaust port to both the supply and the lower cylinder. At about 0.055 seconds, the supply rapid drop slows and the upper cylinder starts to increase in pressure, indicating that the spool piece has completed its travel by closing the exhaust port to these two ports.

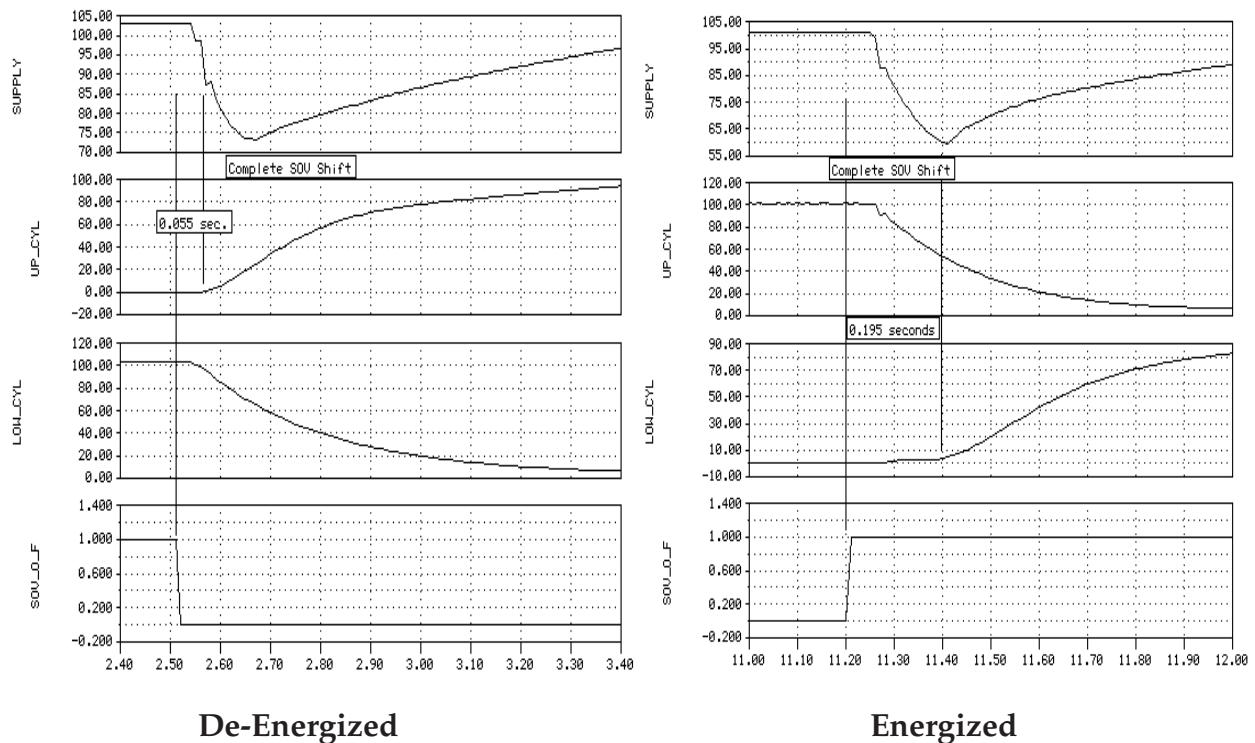

Figure C-29
SOV Pilot Shift Indication at 100 psig

During the energized sequence, the spool piece does not seem to uncover the exhaust port until about 0.06 seconds, at which time the supply drops rapidly; and a short time after, the upper cylinder starts to drop. It takes a full 0.195 seconds for the lower cylinder to start to increase which would signal a complete shift of the spool piece.

Figure C-30 and Figure C-31 show the same test sequence run at about 60 psig and 40 psig, respectively. The figures show that the de-energized sequence is almost identical on both of these tests, indicating that lower volumes have very little effect on the movement of the spool piece in this direction. This is not true for the energized sequence because it took 0.354 seconds to complete the travel during the 60 psig test; and during the 40 psig test, the spool piece did not complete its movement. The figure shows that it dumped almost all of the supply pressure out the exhaust port, leaving the SOV inoperable.

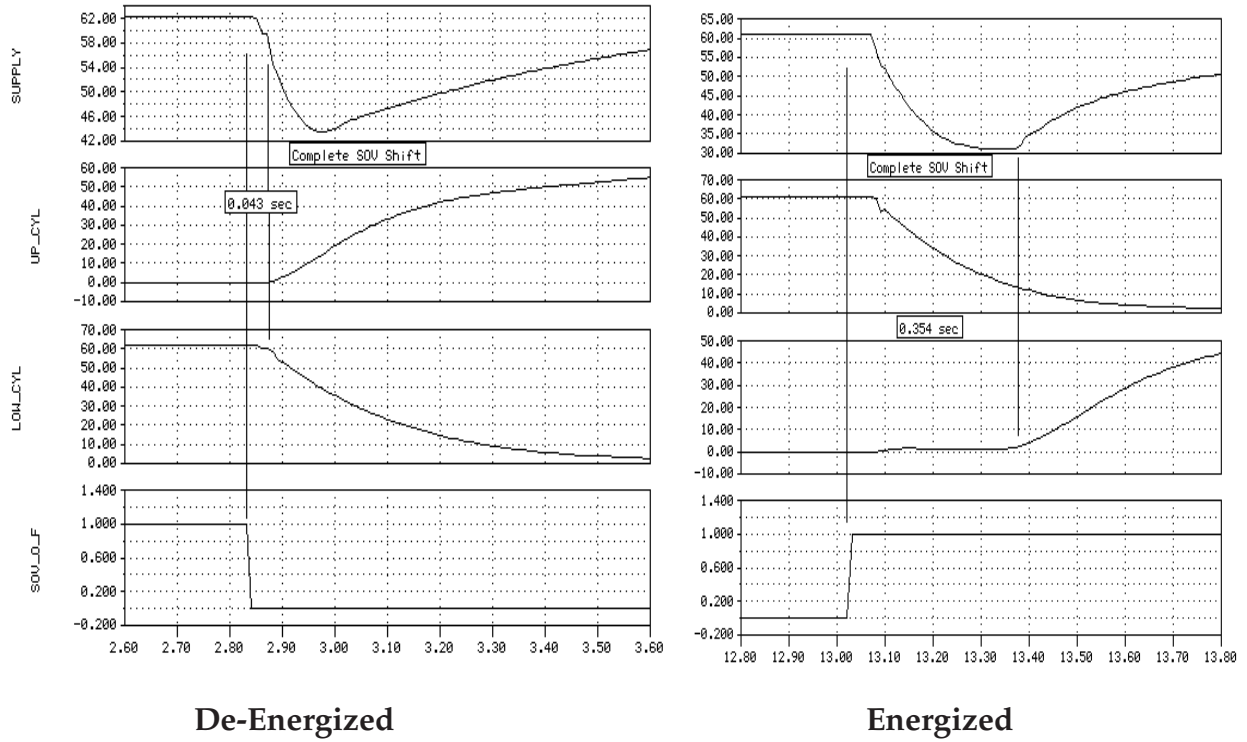

Figure C-30
SOV Pilot Shift Indication at 60 psig

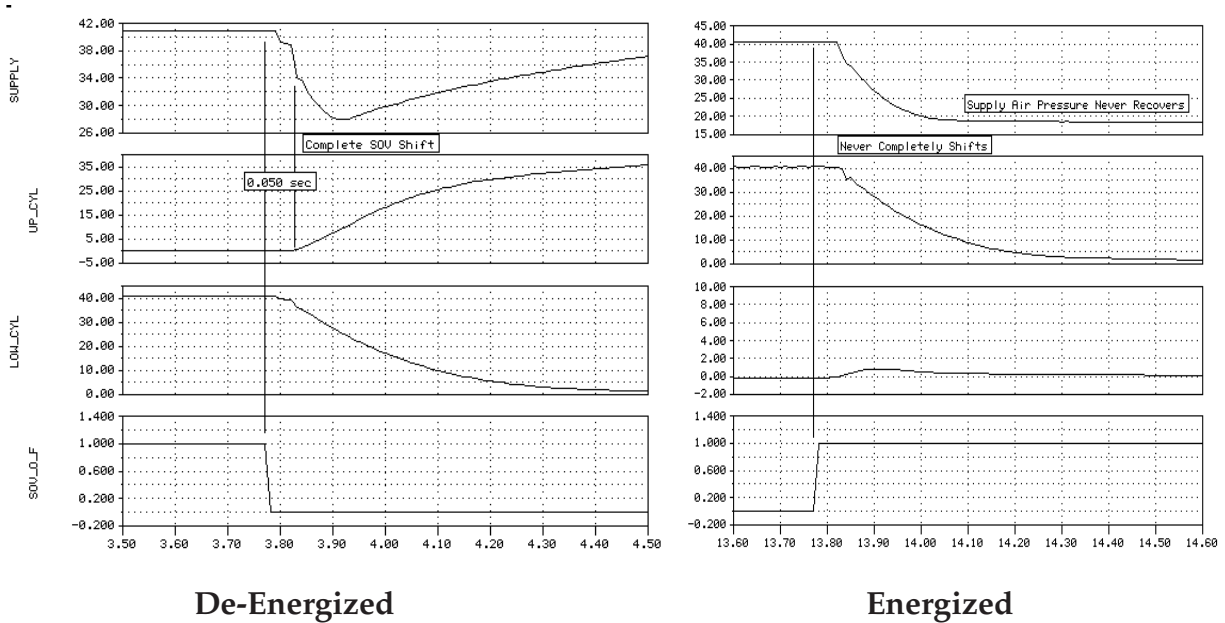

Figure C-31
SOV Pilot Shift Indication at 40 psig

APPENDIX D1

ACTUATOR SELECTION BY GAYLE E. BARB

Reprinted by permission. Copyright Instrument Society of America 1984. From Advances In Instrumentation, Volume 39.

ABSTRACT

Actuator selection when using spring opposed pneumatic diaphragm and piston actuators involves the unique combination of many variables. Analysis of many combinations is made showing the resultant direction of force action from the variables considered. The combinations are further grouped as to stability of process and control valve operations. Principal forces related to the process, valve, and actuator are developed. Stability criteria are also presented.

Actuator Selection

The pressure in the actuator represents the answer or solution to the free body diagram encompassing the variables of the actuator, valve, and process. A typical free body diagram is shown in figure D1-1. The purpose of pressure in the actuator is to position the valve closure member for proper process control. Engineers and buyers of process control systems have for many years been specifying systems such that the actuator pressures would match controller output ranges of 3-15 and 3-27 (6-30) psig. The valve would thus assume a position proportional to the controller output pressure. Recognizing the variables of packing friction and "seat leak" force, one concludes that the ideal controller output ranges cannot be achieved. The real objective then is to select system variables such that the ideal 3-15 and 3-27 (6-30) psig controller output ranges can be closely realized. These must be compatible with the valve in service, process conditions, and/or leak class requirements.

The principal forces are considered in this presentation. Economics, i.e., the point of insignificant returns, justify ignoring some known force variables such as air and fluid damping, closure member weight, inertia forces, etc. Should a more rigorous analysis be required, it could be accomplished using such parameters.

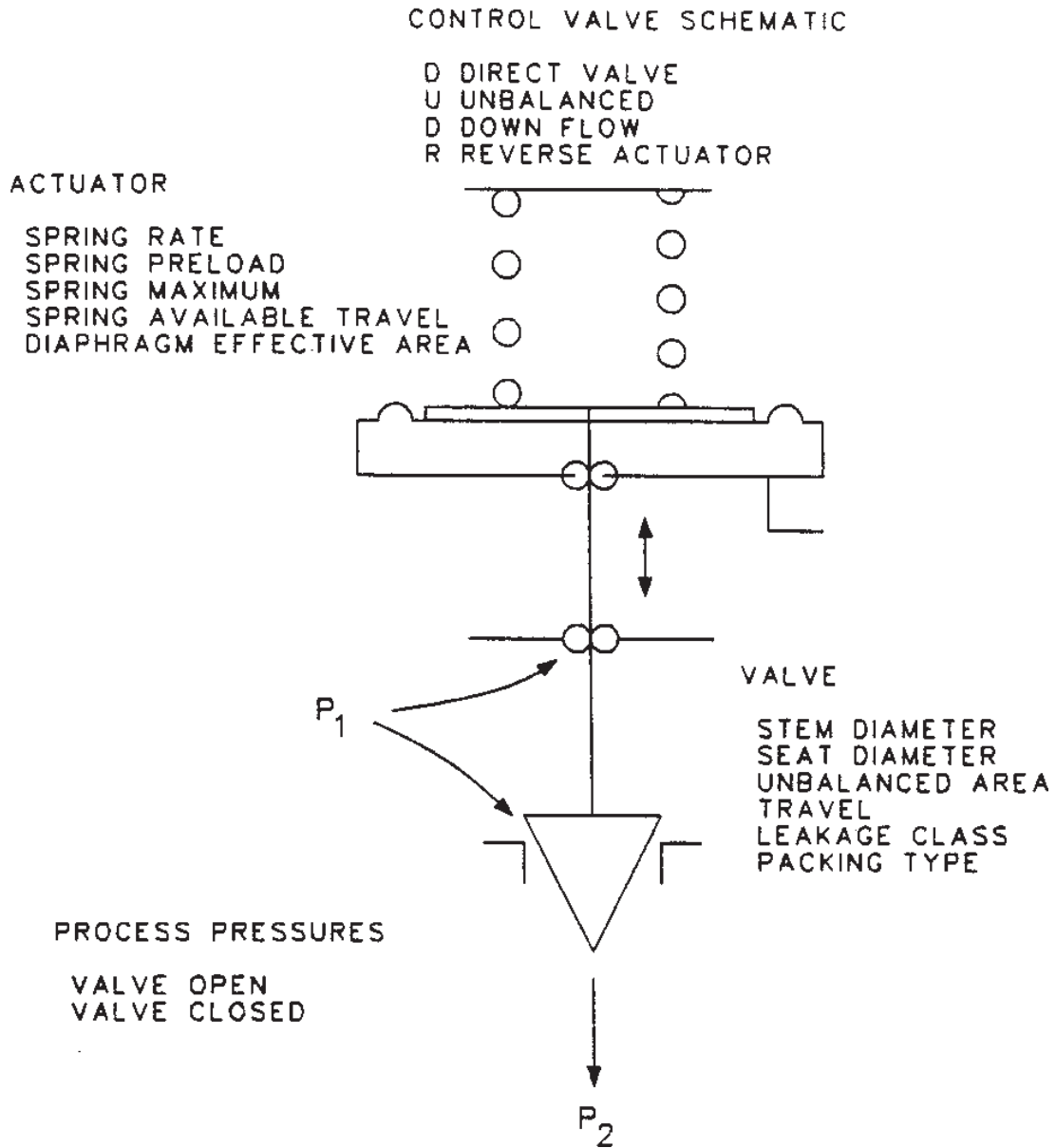

Figure D1-1
Force Balance Diagram

Stem Force

The stem force is simply the area of the stem times the pressure in the valve body acting on the stem. Normally, valve open and valve closed positions result in different values of stem force.

Packing Friction Force

The packing friction force acts to impede stem movement and is considered to be a constant value, consistent with packing type and pressure class. Therefore, the packing friction force equals the stem diameter times a packing friction factor. The packing friction force is recognized to be a function of many variables. Using a representative value is considered to be prudent rather than ignoring the issue. When other application information indicates better accuracy, it should be used. Suggested packing friction factors are shown in table D1-1.

Leak Class Force

The closure member must contact the seat with some force to establish an initial seal, consistent with the leak class used. The unit force (unit circumference) may be represented in the general form of an equation for a straight line (i.e., $y = mx + b$). The leak class force then equals the differential pressure times a slope factor, plus a "y" intercept factor times the diameter of the port times π . The suggested slope and "y" intercept factors are shown in table D1-2 for several ANSI/ISA B16.104 seat leakage classifications and conditions. A specified leak class often requires other than ideal output pressure ranges be used.

Closure Member Force

Closure member force is that force created by the process acting on the closure member. The closure member force equals the differential pressure times the closure member unbalanced area, times a closure member unbalanced area factor. This force magnitude can be extremely complex, considering flow direction, valve type, closure member flow characteristic, and valve travel. The factor is one when the valve is full closed, and may be assumed as zero at full open position. Analysis at intermediate points requires application of this factor and pressure drop across the valve at all desired points. A typical plot of factor versus travel is shown for one closure member in figure D1-2.

Spring Force

The spring creates a force which is a function of its initial compression or preload, valve travel, and spring rate. The equation for spring force then becomes: spring force equals spring preload plus the product of valve travel, valve travel factor, and spring rate. Spring preload and valve travel are in units of distance. The valve travel factor accounts for the point of analysis, and will vary from zero to one.

Table D1-1 PACKING FRICTION FACTORS

$$F_p = (\pm F_{FP})(D_s)$$

where:

F_p = Packing Friction Force

F_{FP} = Packing Friction Factor

D_s = Stem Diameter

Force = (+/- Factor)(Stem Diameter)

F_{FP}	Packing Type	Pressure Rating
100	Single TFE	All
150	Double TFE	All
233.3	TA	125
293.3	TA	250
233.3	TA	150
308.5	TA	300
431.25	TA	600
582.5	TA	900
687.5	TA	1500
811.5	TA	2500
466.7	Graphite	150
612.5	Graphite	300
862.5	Graphite	600
1125	Graphite	900
1375	Graphite	1500
1622.5	Graphite	2500

Legend:

TFE Teflon V-Ring

TA Teflon Asbestos

Table D1-2 SEAT LOAD FORCE

ANSI B16.104 Seat Leakage Classification	Seat Load to Prolong Seat Life Using Metal Seats
II	Force = $(0.0167 \Delta P + 25)D_p\pi$
III	Force = $(0.0333 \Delta P \text{ psi} + 70)D_p\pi$
IV	Force = $(0.0500 \Delta P \text{ psi} + 100)D_p\pi$
V	Force = $(0.1208 \Delta P \text{ psi} + 100)D_p\pi$
	Seat Load Using Metal Seat Where Tight Shut Off Is Not A Prime Consideration
II	Force = $20D_p\pi$
III	Force = $40D_p\pi$
IV	Force = $60D_p\pi$
V	Force = $(0.1208 \Delta P \text{ psi} + 100)D_p\pi$
	Seat Load Using Teflon Or Other "Soft Seat" Designs
All	Force = $(0.0126 \Delta P \text{ psi} + 30)D_p\pi$

where:

ΔP = differential pressure psi

D_p = port diameter

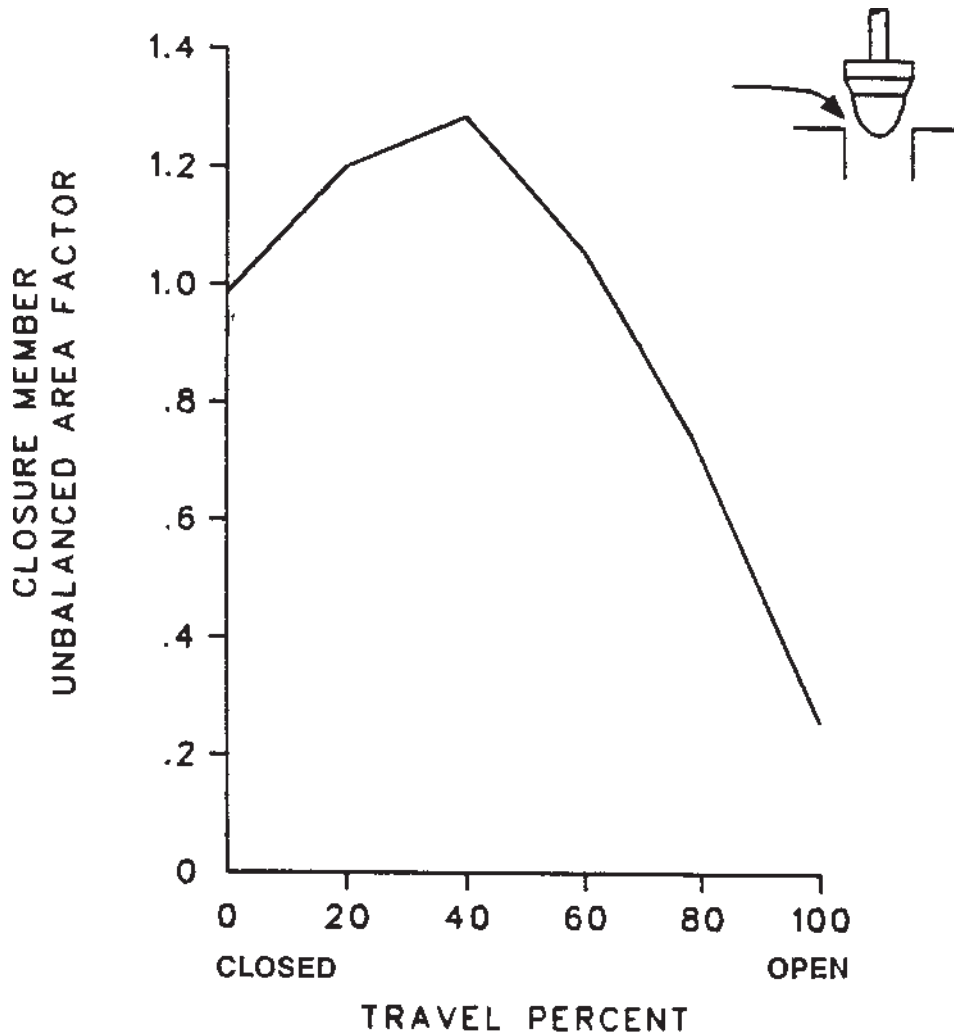

Figure D1-2
Closure Member Unbalanced Area—Factor versus Travel Percent

Actuator Force

The actuator force is the actuator effective area times the actuator effective area factor, times the actuator pressure. The actuator effective area factor is used to account for area variation.

Stability Analysis

One more equation and factor are required when a process and control valve stability analysis is performed per the air mass stability criteria. Three stability criteria are as follows:

- Spring Rate Criteria
 - Stability will be obtained when the rate of change of spring force (spring rate) is greater than two times the rate of change of stem force (process rate).

- A System With No Positioner
 - For stability, the pressure in the actuator must always increase or decrease with valve travel
- A System Using A Positioner
 - For stability, the mass of air in the actuator must always increase or decrease with valve travel

Actuator Air Mass

The mass of air (standard volume) in the actuator is one of the criteria. The mass of air, among other things, is a function of the actuator tare volume. The tare factor is considered to be some decimal portion of the actuator effectiveness area, and accounts for the tare or clearance volume which exists in the actuator. The actuator mass equals the product of the actuator effective area times the actuator effective area factor, times the quantity valve travel, times the valve travel factor plus the tare factor, times the quantity actuator pressure plus 14.7, all divided by 14.7.

Direction Of Force Action

The actuator air pressure, or air mass, is the controlled variable which is the result or answer calculated from the force summation. The force summation is the combination of all forces acting in the appropriate direction consistent with the valve and actuator type. A sign convention of up being positive and down being negative is selected. The valve and actuator types and flow direction are identified by a series of letters. Flow direction considers actuator vertical up orientation. These codes are described in table D1-3.

Table D1-3 IDENTIFICATION OF LETTER CODES

Valve Action Type	Code Letter
Direct (Push Down to Close)	D
Reverse (Push Down to Open)	R
Valve Balance Type	
Balanced (Semi-Pressure Balanced)	B
Unbalanced	U
Flow Direction Type (Actuator Vertical Up)	
Up (Through Top Port of Double Port)	U
Down	D
Actuator Type	
Direct (Air To Extend)	D
Reverse (Air to Retract)	R

Table D1-4 is a summary of all the presented information regarding direction of force action with various valve and actuator combinations. The force summation or resultant (changed to a positive integer) is divided by the actuator effective area, corrected by its factor, to give the actuator air pressure. The actuator air pressure can now be compared to the controller output ranges to test for a satisfactory match. Testing against controller output ranges implies analysis at valve full open or full closed positions only. Table D1-4 summarizes direction of force action and also places the valve action, balance, flow, and actuator into stable, possibly unstable, and potentially unstable groups. Further separation as to single port, double port, and cage designs aids in this summary of information.

Stability

Assuming that prediction of stability and a stability criteria evaluation is desired, it is suggested that data analysis be made at no less than 20 percent travel increments. Economics dictate that unnecessary work not be performed. Analysis of valve actuator combinations results in the following groupings.

Stable Combinations

Stable combinations are DUUD, DUUR, RUDD, and RUDR. The slope of the closure member force vs. travel and the spring force are in the same direction (i.e., both positive or both negative slope). The closure member force does not have a force slope reversal. These two observations, as the valve travels from closed to open (open to closed), make the combinations stable. Stability analysis is not required for these combinations.

Potentially unstable combinations are DUDD, DUDR, RUUD, and RUUR. The slope of the closure member force vs. travel and the spring force are basically in different directions (i.e., one is positive slope and one is negative slope). The closure member force does have a force slope reversal or "bath tub stopper effect." These two observations, as the valve travels from closed to open (open to closed), make the combinations potentially unstable.

The top and bottom guided double port (semi-pressure balanced) combinations DBUD, DBUR, RBUD, and RBUR can be possibly unstable in service. Closure member force does have a force slope reversal. Conventional flow direction of up through the top port is the only direction considered. Cage valves DBBD, DBDR, RBUD, and RBUR also can be possibly unstable in service as the closure member can also experience force reversals.

The force equations are listed below for convenience. The manipulation of the equations and their combinations are readily reduced to a solution using a programmable calculator.

Conclusions

Air pressure is the solution to the choice of the actuator variables.

Spring rate, air pressure, or air mass are used as stability criteria where applicable to the analysis technique.

Actuator, valve, and flow direction are analyzed to predict stable, potentially unstable, and possible unstable combinations.

Conflicting requirements nearly always make ideal in-service instrument ranges impossible to attain.

Equations

$$\text{Stem Force} = D_s^2 (\pi/4) (P_1) = D_s^2 (\pi/4) (P_2)$$

$$\text{Packing Friction Force} = (D_s)(F_{FP})$$

$$\text{Leak Class Force} = (((P_1 - P_2) M) + Y)(D_p) \pi$$

$$\text{Closure Member Force} = (\text{CMU}) (A_{\text{CMU}})(P_1 - P_2)$$

$$\text{Spring Force} = (L_s + X_{VT})(R_s)$$

$$\text{Actuator Force} = (\text{AEA})(A_{EA})(P_A)$$

$$\text{Actuator Air Mass} = ((\text{AEA})(A_{EA})(X_{VT})(VT + \tau)(P_A + 14.7))/14.7$$

where:

D_s = Stem diameter

P_1 = Upstream pressure

P_2 = Downstream pressure

F_{FP} = Packing friction factor

M = Slope factor

Y = Intercept factor

D_p = Port diameter

CMU = Closure member unbalanced area factor

A_{CMU} = Closure member unbalanced area

L_s = Spring preload

X_{VT} = Valve travel

VT = Valve travel factor

R_s = Spring rate

A_{EA} = Actuator effective area

AEA = Actuator effective area factor

P_A = Actuator pressure

τ = Tare factor

BIBLIOGRAPHY

1. J. T. Muller. *Selecting Spring Spans For Control Valve Actuators*. Fluid Controls Institute, 1965.
2. Floyd P. Harthun. "Effect of Fluid Compressibility On Torque In Butterfly Valves." *ISA Transaction*, Vol. 8, No. 4, 1969.
3. Richard F. Lytle. "Valve Plug Force Effects on Pneumatic Actuator Stability." Presented ISA '70 Conference (765-70).
4. Gareth A. Keith. "Analytical Prediction of Valve Stability." Presented ISA '70 Conference (838-70).
5. Charles B. Schuder. "Understanding Fluid Forces In Control Valves." *Instrumentation Technology Journal of ISA*, May 1971.
6. C. E. Wood and A. R. Nenn. "Problems of Undersized Actuators." Presented ISA '72 Conference.
7. Gareth A. Keith. "Steam Dump Valve Stability." Presented ISA '77 Conference.
8. W. G. Gulland and A. F. Scott. "Hammering Control Valves - Diagnosis and Solution Of A Stability Problem." *Transactions Instrument Measurement Control*, Vol. 3, No. 2, April, June 1981.
9. Gayle E. Barb. "Control Valve And Process Stability." Presented ISA '82 Conference.

APPENDIX D2

D2.1 EXAMPLE CALCULATION

The example starts with the input data concerning the actuator, valve, and the process. Next the force results are calculated with reference to the equations of this document. The force results are summed in the appropriate manner to obtain the actuator pressures which are the solution to the free body diagram of the actuator, valve and process.

D2.2 COMBINATION

Appendix "D2" is the combination DUUD-SP

- D Direct Valve Action Type (Push down to close)
- U Unbalanced Construction
- U Up Flow (Assembly standing vertical with the actuator on top)
- D Direct Actuator Type (Increase air to extend stem)
- SP Single Port Globe Valve

D2.3 APPENDIX “D2” EXAMPLE INPUT DATA

Actuators and valves only come in certain sizes each with their respective dimensions. Process conditions are infinite thus it is prudent to enter the following data, calculate forces and then solve for the solution to the free body, ie actuator pressure. The following simple formula provides help in selection of preliminary values.

$$\frac{\text{Actuator Eff. Area (in}^2\text{)} \times \text{Control Span (psi)}}{\text{Valve Travel (in)}} = \text{Spring Rate (lb/in)}$$

Actuator, valve and process, data

	VALUE	UNITS	DESCRIPTION
ACTUATOR	140	in ²	Actuator Effective Area
	1120	lb/in	Spring Rate
	3.260	in	Spring Available Travel
	0.4308	in	Spring Preload
VALVE	100		Packing Factor
	0.050		Leak Class Seat Load Slope Factor
	100		Leak Class “Y” Intercept Factor
	1.50	in	Valve Travel
	0.625	in	Stem Diameter
	3.00	in	Seat Port Diameter
	7.069	in ²	Closure Member Unbalanced Area
PROCESS	100.0	psid	Shut-off Differential Pressure
	120.0	psig	Pressure on Stem End (Valve Open)
	20.0	psig	Pressure on Stem End (Valve Closed)

D2.4 FREE BODY DIAGRAM

The forces concerning the valve, actuator and process considered for analysis are shown on a free body diagram. Also noted are values concerning the valve, actuator and process used in this example. See Figure D2-1.

D2.5 FORCE RESULTS

	VALUE	UNITS	DESCRIPTION
	482.5	lb	Spring Preload Force Spring Rate x Spring Preload 1120×0.4308
	2162	lb	Maximum Spring Force Spring Rate x (Spring Preload + Valve Travel) $1120 \times (0.4308 + 1.5)$
	36.82	lb	Stem End Load (Valve Open) Stem Area x Pressure Stem (Valve Open) $0.625^2 \times (\pi/4) \times 120$
FORCE RESULTS	6.136	lb	Stem End Load (Valve Closed) Stem Area x Pressure on Stem (Valve Closed) $0.625^2 \times (\pi/4) \times 20$
	989.6	lb	Seating Force of Closure Member Equation BE 4 $((0.050 \times 100) + 100) \times 3.0 \times \pi$
	706.9	lb	Diff. Pressure Force on Closure Member Shut-off Diff. Pressure x Unbalanced Area 100×7.069
	62.5	lb	Packing Friction Drag Force Packing Factor x Stem Diameter 100×0.625

D2.5.1 REFERENCED EQUATION BE 4

Leakage Class Contact Force for ANSI/FCI 70-2

Leakage Class IV

Force = ((Differential Pressure x Slope Factor) +
"y" Intercept Factor) x Diameter of Seat Port x π

Example Equation w/ Values

Force = $((0.050 \times 100) + 100) \times 3 \times \pi$

D2.6 ACTUATOR PRESSURE CONDITIONS

The actuator pressure conditions are installed, inherent, and bench. See Section D2.8 for definitions. The actuator pressure is the result of the summation of appropriate forces and then dividing by the actuator effective area. The “start travel” position where the valve/actuator combination “fails” upon loss of actuator pressure. The “start travel” position in this example is from the valve “full open”.

	VALUE	UNITS	DESCRIPTION
	4.156	psig	Pressure to Start Valve Travel (482.5 + 36.82 + 62.5) / 140
INSTALLED	20.99	psig	Pressure at Rated Valve Travel (2162 + 6.136 + 62.5 + 706.9) / 140
	20.09	psig	Pressure at Return Valve Travel (2162 + 6.136 - 62.5 + 706.9) / 140
	3.263	psig	Pressure at Original Valve Position (482.5 + 36.82 - 62.5) / 140
	3.893	psig	Pressure to Start Valve Travel (482.5 + 62.5) / 140
INHERENT	15.89	psig	Pressure at Rated Valve Travel (2162 + 62.5) / 140
	15.00	psig	Pressure at Return Valve Travel (2162 - 62.5) / 140
	3.000	psig	Pressure at Original Valve Position (482.5 - 62.5) / 140
BENCH	3.446	psig	Pressure to Start Travel 482.5 / 140
	15.45	psig	Pressure at Rated Travel 2162 / 140

D2.7 SHUT-OFF CONDITON PRESSURE

The actuator pressure for the valve shut-off position is one more value which must be calculated. The Class IV shut-off criteria requires the closure member to contact the seat with a force of 989.6 pounds.

VALUE	UNITS	DESCRIPTION
28.05	psig	Shut-off Condition Pressure (2162 + 6.136 + 62.5 + 706.9 + 989.6) / 140

D2.8 REFERENCED DEFINITIONS

INSTALLED CONDITION Considers the valve, actuator, and process forces acting on the valve/actuator assembly.

INHERENT CONDITION Considers the valve and actuator forces acting on the valve/actuator assembly. No process forces are acting.

BENCH CONDITION Considers only the forces associated with the actuator. Considering spring opposed pneumatic actuators, BENCH CONDITION (Bench Set), pressures at start and rated travel positions are calculated to provide proper valve performance taking into account system operating loads, friction loads, etc., but verified with out those loads present.

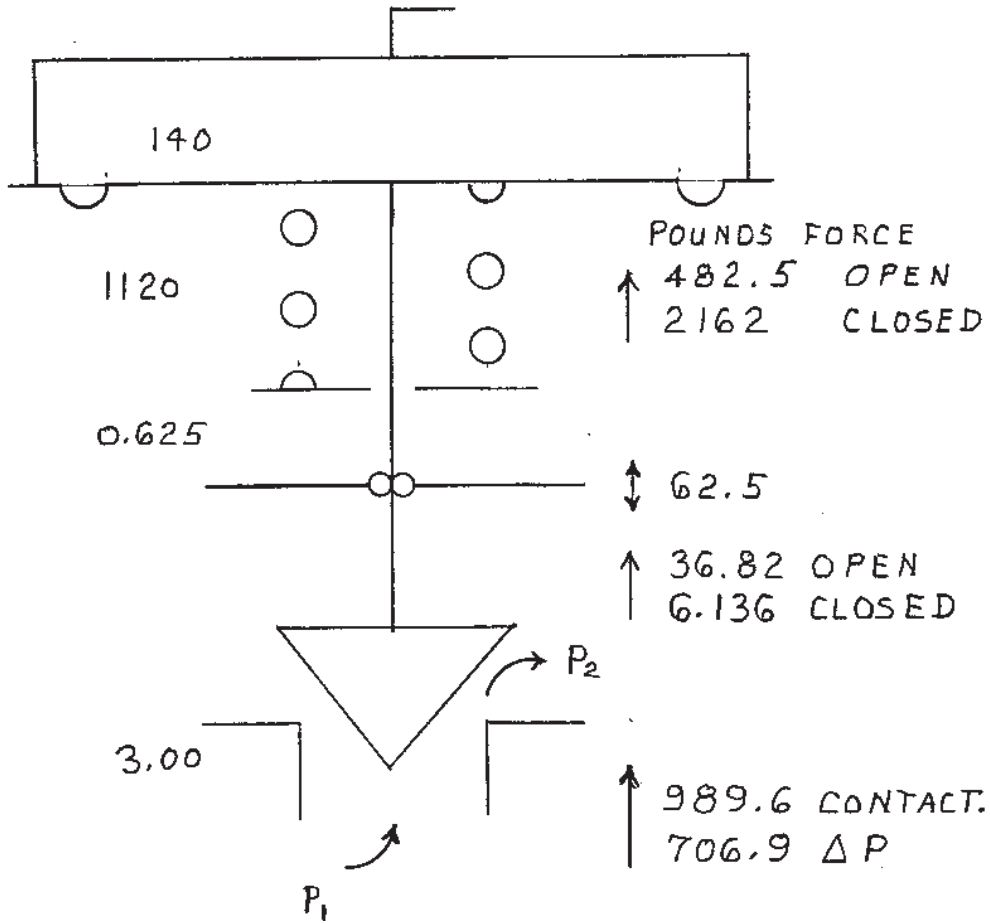

Figure D2-1
Free Body Diagram of a DUUD-SP Valve and Actuator

APPENDIX E

PERIODIC TESTING METHODS FOR SAFETY-RELATED AIR-OPERATED VALVES

PURPOSE

The purpose of this appendix is to present methods of periodic testing of safety-related air-operated valves (AOVs).

DISCLAIMER

The content of this Appendix is solely that of the authors and has not been reviewed or accepted by ASME, NRC, or any other professional organization.

BACKGROUND

The ASME Operations & Maintenance (O&M) Part 19 Working Group is working on a draft *Guide for Preservice and Periodic Performance Testing of Pneumatically- and Hydraulically-Operated Valve Assemblies in LWR Power Plants* (The Guide). The Guide is, at the time of this writing, in the approval stage which means that it could be approved by the ASME as a guideline, or disapproved and sent back to the Working Group for revision.

REQUIREMENTS OF THE GUIDE

Preservice Testing

In its present state, The Guide suggests preservice testing on a new valve when it is replacing a valve that is not “like-in-kind” to the new valve. The purpose of the preservice testing is to prove that the valve can perform its safety-related function and only its safety-related function. For example, if a valve has a safety function to be isolated against 2,000 psig and also has a normal function to flow 400 gpm, the only function that has to be proved is that it can isolate against the 2,000 psig. The Guide is not interested in proving that the valve can flow 400 gpm. The Guide allows a combination of methods to prove that the new valve can meet its safety-related function. These methods include the following:

- Dynamic test at expected service conditions. This requires testing the valve either in the plant or in a flow loop to prove that the valve can perform its safety-related function at the expected conditions.

- Correlation with a similar valve that has been dynamically tested at the same or bounding conditions. This allows for the testing of a single valve that might be one of four in the same or similar service.
- Extrapolation of results of a dynamic test at the highest practicable conditions. This method allows the testing of a valve at a lower condition when the system could not operate at the safety-related function conditions. An example of this would be a valve that had to isolate against a downstream line break. In this example, the valve might be tested at 50%, or some other percentage, of what might be the expected line break pressure differential. This information would then used to prove that the valve could close at the expected safety-related function condition.
- Calculation methods, if it can be shown that the methods provide a conservative result. Here the valve industry's standard sizing calculations, which have been used for years to size the actuators to operate at specified conditions, can be used to prove that the valve is capable of performing its safety-related function. Some of the calculations that have been accepted in the NRC Generic Letter 89-10 response might be used or adapted here.

The Guide also allows the use of any combination of the above methods to prove the operability of the valve. For example to reduce an acceptable margin, a calculation could be done at the actual condition and at a lesser testable condition to prove the acceptability of the calculation when the valve is actually tested at the lesser condition.

Figure E-1 presents an example of combining methods to reduce the margin requirements. The graph is any system parameter versus any valve parameter, for example the differential pressure across the valve versus the seating force required to shut off the system pressure. **C1** might be the point calculated at the accident condition and **Ma** is the margin that has to be considered, based on only the calculation method. **C2** is a point that is calculated at a point where the valve can be tested as installed in the system. **T** is the actual tested condition. Based on the acceptability of the comparison of **C2** and **T**, a new margin can be assigned to the **C1** point, **Mb**.

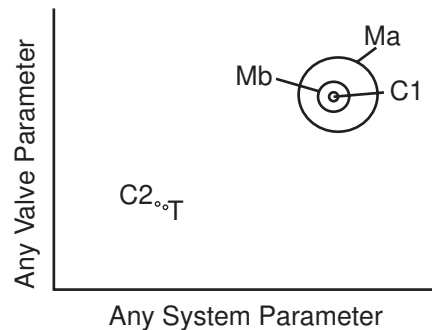

Figure E-1
Combining Methods

In addition to replacing a valve that is not “like-in-kind,” The Guide also is looking for preservice testing of all safety-related valves in any new nuclear power plant.

In general, there are not too many, if any, plants in the U.S. that will be required to meet the preservice testing portion of The Guide. Preservice testing is required only when replacing a valve or building a new system that requires safety-related valves. Of course plants outside the U.S. that are building their plants to U.S. requirements might have to meet this requirement for all of their safety-related valves.

Inservice Testing

The Inservice Testing portion of The Guide will affect most operating plants in the U.S. or plants operating to U.S. standards.

The Guide provides the following guidance as to when inservice testing is performed:

- At a frequency established by the owner
- When a valve assembly has been replaced, repaired, or has undergone maintenance that could affect the valve assembly’s performance
- When a design change affects the system’s operating parameters, for example, increasing the head on a tank would increase the delta P across a valve
- A modification to the valve that changes the operating parameters, for example, changing the actuator spring rate or size of the actuator

The actual inservice testing portion of this requirement is the easy part; the difficult part is establishing the reference values to compare or reconfirm the inservice testing. This requires the owner to determine the values required to perform the safety function. For example, if a valve is required to shut off against a differential pressure, some or all of the following information might be needed to establish the reference values:

- Flow direction (over or under the seat)
- Maximum differential pressure
- Differential area (that the differential pressure is acting against)
- Stem area
- Effective actuator area
- Shut off force required (class IV or V shut off)
- Total friction acting against valve movement

With this information, a required seat load can be calculated to compare to the tested results. The problem is that much of this information is not readily available, and valve vendors are sometimes reluctant to provide their portion of it.

The inservice test is the test that is used to establish the baseline for future testing and can be performed at any system operating condition. The most likely and convenient

condition is the static condition, no pressure and no flow. At this condition, most valves can be tested during an outage; while others, depending on the service, can be isolated and tested while the plant is operating. It is important to note that testing at static conditions does not require trying to maintain or duplicate a system pressure so that the inservice test can be compared to a previous baseline test.

Periodic Valve Stroke Test

The purpose of this test is to make sure that the valve is functional (at the time of the test), in between the inservice testing. This test is required only once every 24 months if the valve hasn't been fully stroked for some other reason during that time period. It does not require the measurement of stroke time but does require documentation that the valve was stroked and did fully stroke.

METHODS OF TESTING

Based on The Guide, the only testing that has to be conducted, where parameters other than stroke are measured, is either the preservice or inservice testing. In general, the same valve parameters must be measured for both types of tests. During the preservice test, system flows and/or pressures might have to be measured, while during the inservice test, if done at a static condition, system parameters do not have to be monitored.

Some utilities might be looking for a quick, non-intrusive way to test their AOVs, such as stroke-timing to determine if a valve is deteriorating. Stroke-timing will not meet the requirements of The Guide, except in the case where the valve's only safety function is to open, close, or do something in a specified amount of time. Because many valves have to both open or close in a specified minimum time, as well as open against critical system parameters, the stroke time test currently performed to comply with Section II requirements, by itself, is probably not adequate.

Table E-1 is a list of different safety functions and what parameters might need to be monitored, as a minimum, during a test.

A combination of requirements might require a combination of parameters to be measured. For example, a valve that has to isolate against pressure within a specified amount of time also needs to have time measured.

Some general guidance when measuring parameters:

- AOV diagnostic equipment is not required to meet the intent of The Guide, but will provide much better and consistent results, and will be able to pick up subtle changes that might be an indication of deterioration.
- When required, actuator pressure should be measured as close to the actuator as possible, so that line losses are not a problem.
- Opening or closing positions should be measured when the valve either leaves the seat or as it contacts the seat. The closed limit switch is not a reliable indication of the closed position.
- The full open position can be indicated by a limit switch because full flow of a valve is normally obtained somewhere around 90% of its full stroke. This position is not usually critical.
- Time should be measured from the time of activation to obtain the true time, including all components (SOV).

Table E-2 provides a comparison of data acquisition methods.

CONCLUSIONS

- The most difficult job is obtaining the information required to determine the acceptance criteria for the inservice testing.
- AOV diagnostic equipment, although not required, is helpful.
- Testing and monitoring these critical valves will make the valves run better and ultimately improve plant safety.

APPENDIX F

GENERAL PROPERTIES OF ELASTOMERS

APPENDIX G

PROPERTIES OF PLASTICS AND ELASTOMERS USED IN VALVES FOR SOFT SEATS, SEALS, AND GASKETS

Teflon (Halon, TFE, Fluon)

Radiation resistance - maximum 10(4) rads
Low coefficient of friction
High chemical resistance
Temperature limit of 400°F
Susceptible to abrasion

Teflon (Glass Filled)

Radiation resistance - maximum 10(4) rads
Low to moderate coefficient of friction
High chemical resistance
Temperature limit of 450°F
Susceptible to abrasion, but better than unfilled Teflon

Nylon (Zytel, Nypel, Fosta)

Radiation resistance - 10(4) rads
High coefficient of friction
Moderate to low chemical resistance
Temperature limit of 250°F
Not susceptible to abrasion

Kel-F (CTFE)

Radiation resistance - 10(7) rads
Low coefficient of friction
Good chemical resistance
Temperature limit of 300°F
Susceptible to abrasion

Tefzel

Radiation resistance - 10(7) rads
Low coefficient of friction
High chemical resistance
Temperature limit of 300°F
Moderate resistance to abrasion

Polyethylene

Radiation resistance - 10(8) rads
Low to moderate coefficient of friction
High chemical resistance
Temperature limit of 180°F
Not susceptible to abrasion

Natural Gum Rubber

Radiation resistance - 10(7) rads
High coefficient of friction
Moderate to low chemical resistance
Temperature limit of 130°F
Not susceptible to abrasion

Buna-N

Radiation resistance - 10(4) rads
High coefficient of friction
Moderate to low chemical resistance
High resistance to petroleum products
Temperature limit of 210°F
Not susceptible to abrasion

Viton

Radiation resistance - 10(7) rads
High coefficient of friction
Good chemical resistance
Temperature limit of 400°F
Not susceptible to abrasion

Ethylene, Propylene, Terpolymer

Radiation resistance - 10(8) rads
High coefficient of friction
Moderate to low chemical resistance
Temperature limit of 300°F
Not susceptible to abrasion

APPENDIX H

RADIATION RESISTANCE OF PLASTICS

Group 1

Plastics retaining satisfactory properties after exposure to 10(10) rads

Phenolic, glass laminate

Phenolic, asbestos filled

Polyurethane

Group 2

Plastics retaining satisfactory properties after exposure to 10(9) rads

Epoxy, aromatic curing agent

Furane resin (Duralon)

Polyester, glass filled

Polyester, mineral filled

Polystyrene (Amphenol, Styron)

Polyvinyl carbazole (Polectron)

Silicone, glass filled

Silicone, mineral filled

Group 3

Plastics retaining satisfactory properties after exposure to 10(8) rads

Polyethylene

Polyester film, unfilled (Mylar)

Polyvinyl chloride* (PVC, Tygon, Pliovac)

Polyvinyl Formal (Formvar)

Silicone, unfilled

Polypropylene

Group 4

Plastics retaining satisfactory properties after exposure to 10(7) rads

Aniline - Formaldehyde (Cibanite)

Cellulose acetate (Tenite, Celanese)

Melamine - Formaldehyde (Melmac)

Monochlorotrifluoroethylene* (Kel-F, Polyfluron Fluorothene)

Phenol formaldehyde, fabric filler (Bakelite)

Phenolic, unfilled

Polycarbonate (Lexan, Merlon)

Polyvinylidene chloride* (Saran)

Urea - formaldehyde

PVF (Polyvinyl fluoride)

PVDF (Polyvinyl difluoride)

Group 5

Plastics retaining satisfactory properties after exposure to 10(6) rads

Polymide (Nylon, Zytel)

Polyester, unfilled

Polyformaldehyde (Delrin, Celcon)

Polymethyl alpha - Chloracrylate (Gafite)

Vinyl chloride - acetate

Group 6

Plastics retaining satisfactory properties after exposure to 10(5) rads

Tetrafluoroethylene* (Teflon)

*Tests have shown these materials to evolve halogenated gases due to radiation exposure, possibly at lower doses than indicated here; their use should be restricted.

APPENDIX I

SAMPLE VALVE DATA SHEET

Plant Information

Valve Identification _____
 System Train _____
 Location _____
 Vendor Manual _____
 Drawing Number _____
 P&ID _____
 Electric Schem. _____
 Component _____

Scheduling Information

Start Date _____
 Complete Date _____
 Work Order Number _____
 Radiation Work Permit (RWP) _____
 Scaffolding Order _____
 Hot Work Permit _____
 PMS/IST Code _____

Equipment Information

Clearances Valve _____
 Clearances Electrical _____
 Gage Cal. Date _____
 Gage # _____
 Torque Wrench Cal. Date _____
 Torque Wrench # _____
 Special Tools Cat. I _____
 Multimeter # _____
 Timer # _____
 Other # _____
 Pad Test Data _____
 "I" Beam Clamp _____
 Press. Vessel Code Limits _____

On-Hand
 Location

Order Date

_____	_____
_____	_____
_____	_____
_____	_____
_____	_____
_____	_____
_____	_____

Parts Information

Studs, Size _____
 Nuts, (Wrench Size) _____
 O-Rings Material _____
 Diaphragm _____
 Packing _____
 Filter Element _____
 Gaskets _____
 Other _____

Attach

Valve Signatures, as left, as found
 Man hours from last repair or test

APPENDIX J

VALVE MAINTENANCE CLEARANCE DATA

SHEET 1

GATE - GLOBE - PLUG										
PRESSURE RATING	SIZE	CLEARANCES						D-RIGGING FOR CHAIN FALL		
		HORIZONTAL INSTALLATION			VERTICAL INSTALLATION			HEIGHT	WIDTH	DEPTH
		INCHES								
A	B	C	A	B	C					
300 LB AND LESS	2 1/2	8	6	14	8	6	14	NOT REQUIRED		
	3	10	8	16	10	8	16			
	4	10	8	16	10	8	16	3'-6"	2'-0"	2'-0"
	6-10	12	10	24	12	10	24			
	12-16	16	12	36	14	12	30			
	18-24	20	12	44	18	12	38			
600 LB	2	10	8	16	10	8	16	NOT REQUIRED		
	2 1/2	12	10	18	12	10	18			
	3-4	12	10	18	12	10	18	3'-6"	2'-0"	2'-0"
	6-10	14	10	28	14	10	28			
	12-14	14	12	30	16	12	36			
	16	14	12	30	16	12	36	4'-6"	2'-6"	2'-0"
	18-24	18	12	38	20	12	44			
900 LB AND GREATER	2	10	8	16	10	8	16	NOT REQUIRED		
	2 1/2-4	12	10	18	12	10	18	3'-6"	2'-0"	2'-0"
	6-8	14	10	28	14	10	28			
	10	14	10	28	16	10	36	4'-6"	2'-6"	2'-0"
	12-16	14	12	30	16	12	36			
	18-24	18	12	38	20	12	44			

SHEET 2

BALL										
PRESSURE RATING	SIZE	CLEARANCES						D-RIGGING FOR CHAIN FALL		
		HORIZONTAL INSTALLATION			VERTICAL INSTALLATION			FEET		
		INCHES						HEIGHT	WIDTH	DEPTH
		A	B	C	A	B	C			
300 LB AND LESS	2 1/2	8	6	14	SAME AS HORIZONTAL INSTALLATION	NOT REQUIRED				
	3	10	8	18		NOT REQUIRED				
	4-6	10	8	18		3'-6"	2'-0"	2'-0"		
	8-10	12	10	24						
	12	12	10	24						
600 LB	2	10	8	16		NOT REQUIRED				
	2 1/2	12	10	20		NOT REQUIRED				
	3-6	12	10	20		3'-6"	2'-0"	2'-0"		
	8-10	14	10	28						
	12	14	12	28						
900 LB AND GREATER	2	10	8	16		NOT REQUIRED				
	2 1/2-6	12	10	20		3'-6"	2'-0"	2'-0"		
	8	14	10	28						
	10	14	10	28		4'-6"	2'-6"	2' 0"		
	12	14	12	28						

SHEET 3

BUTTERFLY																			
PRESSURE RATING	SIZE	CLEARANCES						D-RIGGING FOR CHAIN FALL											
		HORIZONTAL INSTALLATION			VERTICAL INSTALLATION			HEIGHT	WIDTH	DEPTH									
		INCHES																	
		A	B	C	A	B	C												
300 LB AND LESS	3	8	8	14	SAME AS HORIZONTAL INSTALLATION						NOT REQUIRED								
	4-6	10	10	18															
	8-10	14	10	24															
	12-14	14	12	24							3'-6"	2'-0"	2'-0"						
	16-24	18	12	34							4'-6"	2'-6"	2'-0"						
	26-34	21	12	42							NOT REQUIRED								
	36-40	24	12	52															
600 LB	3	8	8	14							SAME AS HORIZONTAL INSTALLATION						NOT REQUIRED		
	4-6	10	10	18															
	8-10	14	10	24															
	12-14	14	12	24													3'-6"	2'-0"	2'-0"
	16-24	18	12	34													4'-6"	2'-6"	2'-0"
	26-34	21	12	42													NOT REQUIRED		
	36-40	24	12	52															

SHEET 4

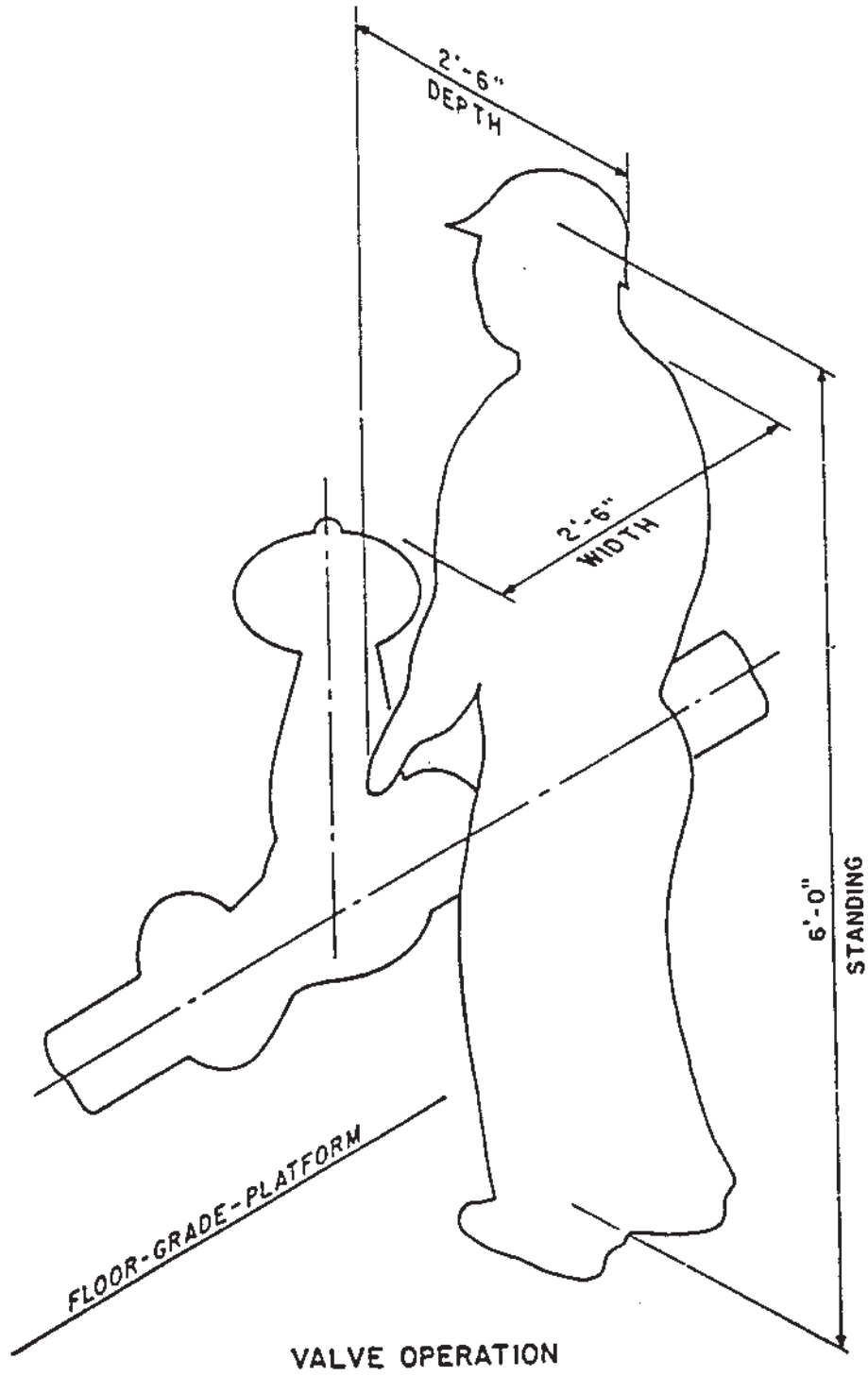

SHEET 5

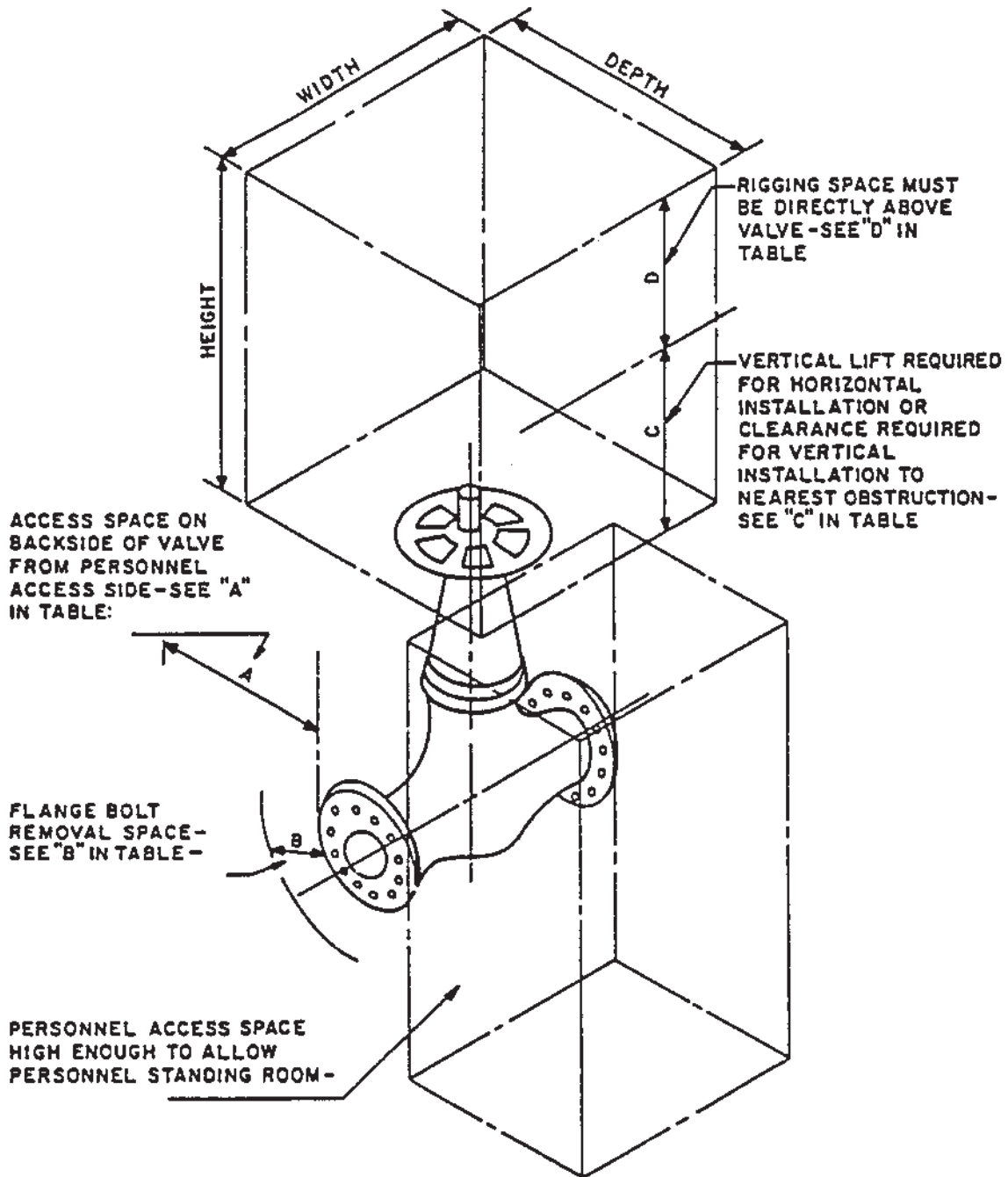

APPENDIX K

ACTUATOR AND ACCESSORY MANUFACTURERS

Actuator and Accessory Manufacturers

Company/Address	A	P	T	B	Company/Address	A	P	T	B
	ctuator	ositioner	ransducer	ooster		ctuator	ositioner	ransducer	ooster
Anchor/Darling Valve Co.	X				Fisher Controls Intl. Inc.	X	X	X	X
701 First St.					205 South Center St.				
PO Box 3428					Marshalltown IA 501158				
Williamsport, PA 17701					515-754-3011				
717-327-4800					FAX 515-754-2830				
FAX 717-327-4805									
Atwood & Morrill Co. Inc	X				GH Bettis	X	X		
Canal Street					18703 GH Circle				
Salem, MA 01970					PO Box 508				
508-744-5690					Waller, TX 77484				
FAX 508-741-3626					713-463-5100				
					FAX 713-463-5103				
Bailey Controls Company		X			Honeywell Inc.		X		
29801 Euclid Ave.					Process Control Division				
Wickliffe, OH 44092					1100 Virginia Dr.				
216-585-8500					Fort Washington, PA 19034				
FAX 216-943-4609					215-641-3000				
Control Components Inc.	X				ITT Conoflow		X	X	
22591 Avenida Empresa					ITT Fluid Technology Corp				
Rancho St. Margarita, CA 92688					Route 78				
714-858-1877					PO Box 768				
FAX 714-858-1878					St. George, SC 29477				
					803-563-9281				
Copes-Vulcan Inc.	X	X			FAX 803-563-2131				
Martin & Rice Ave.					ITT Engineered Valves	X			
Lake City, PA 16423-0577					114 Mayfield Ave				
814-774-1500					PO Box 3053				
FAX 814-774-1681					Edison, NJ 08818-9869				
Dresser Masoneilan	X	X	X		800-548-8382				
Dresser Valve & Controls Division					FAX 717-291-2025				
16503 Park Row					Keystone Controls, Inc.	X	X		
Houston, TX 77084					7241 N. Gessner				
713-492-0753					Houston, TX 77040				
FAX 713-492-6892					713-937-5477				
					FAX 713-937-5449				

Company/Address		A c t u a t o r	P o s i t i o n e r	T r a n s d u c e r	B o o s t e r	Company/Address		A c t u a t o r	P o s i t i o n e r	T r a n s d u c e r	B o o s t e r
Moore Products Co.			X	X	X	Velan Valve Corporation		X			
Sumneytown Pike						Avenue C					
Spring House, PA 19477						Griswold Industrial Park					
215-646-7400						Williston, VT 05495					
						514-748-7743					
Neles-Jamesbury		X	X			FAX 515-748-8635					
640 Lincoln St.											
Worcester, MA 01605						Xomox Corporation		X			
508-852-0200						4444 Cooper Road					
FAX 508-852-8172						Cincinnati, OH 45242					
						513-745-6000					
Valtek Inc.		X	X	X		FAX 513-745-6972					
Mtn Springs Pkwy											
PO Box 2200											
Springville, UT 84663-0903											
801-489-8611											
FAX 801-489-3719											

APPENDIX L

BIBLIOGRAPHY

1. J. A Aikin, G. L. Doubt, C. R. Lade, "A Summary of the Chalk River Valve Packing Evaluation Program," 1990.
2. Asea Brown Broveri, AirCEt, "On the Job Training (OJT)," Training Course, 1991.
3. *Lubrication Guide*, Electric Power Research Institute, Palo Alto, CA: February 1995. Report NP-4916R2.
4. Code of Federal Regulations, 10 CFR 50, RIN: 3150-AD00, "Monitoring the Effectiveness of Maintenance at Nuclear Power Plants," Final Rule, 1991.
5. David Cooper, "Report on the Use of the Fisher Flowscanner: An Air Operated Valve Diagnostic Tool," Bruce Nuclear Generating Station A, 1991.
6. Fisher Controls International, Inc., *Control Valve Handbook*, Second Edition, 1977.
7. Fisher Controls International, Inc., *Control Valve Sourcebook: Power and Severe Service*, Second Edition, 1990.
8. Fisher Controls International, Inc., *General Catalog 501*, 5th Edition, 1989.
9. Fisher Controls International, Inc., *Student Guide*, Various, 1988-1989.
10. William V. Fitzgerald, "Automated Control Valve Troubleshooting: The Key to Optimum Valve Performance," 1991.
11. Fluid Controls Institute, Inc., "Regulator Terminology," 1986. FCI-86-2.
12. *Guide for the Application and Use of Valves in Power Plant Systems*, Electric Power Research Institute, Palo Alto, CA: August 1990. Report NP-6516.
13. *Guide to Optimized Replacement of Equipment Seals*, Electric Power Research Institute, Palo Alto, CA: March 1990. Report NP-6731.
14. Ken Hargreaves, "Report on Control Valve Diagnostics at Ontario Hydro Bruce Generating Station B," 1991.

15. *Solenoid Valve Maintenance and Application Guide*, Electric Power Research Institute, Palo Alto, CA: April 1992. Report NP-7414, 1991.
16. Institute of Nuclear Power Operations (INPO 83-024), Good Practice MA-306, "Planned Valve Repacking as Preventive Maintenance," 1983.
17. Instrument Society of America, ISA-S20.50, *Specification Forms for Process Measurement and Control Instruments, Primary Elements and Control Valves*, 1981.
18. Instrument Society of America, ISA-S75.05, *Control Valve Terminology*, 1983.
19. Power Safety International, "Diaphragm Actuator and Control Valve Maintenance: Student Manual," 1991.
20. *Valve Stem Packing Improvements*, Electric Power Research Institute, Palo Alto, CA: May 1988. Report NP-5697.
21. *Good Bolting Practices: A Reference for Nuclear Power Plant Maintenance Personnel, Vol. 2: Small Bolts and Threaded Fasteners*, Electric Power Research Institute, Palo Alto, CA: December 1990. Report NP-5067.
22. *Instrument Air Systems: A Guide for Power Plant Maintenance Personnel*, Electric Power Research Institute, Palo Alto, CA: December 1990. Report NP-7079.
23. William V. Fitzgerald, "Control Valves for the Chemical Process Industries," 1995.
24. *Guidelines for the Selection and Application of Power Plant Control Valves*, Electric Power Research Institute, Palo Alto, CA: March 1993. Report TR-102051-R1.
25. *Bolted Joint Maintenance and Applications Guide*, Electric Power Research Institute, Palo Alto, CA: December 1995. Report TR-104213.
26. J. Brandrup and E. H. Immergut, *Polymer Handbook*, Third Edition, John Wiley and Sons, Inc.: New York, NY, 1989.
27. L. Engel, H. Klingele, G. Ehrenstein, and H. Schaper, *An Atlas of Polymer Damage*, Prentice-Hall, Inc.: New York, NY, 1981.
28. W. Schnabel, *Polymer Degradation*, Macmillan Publishing Co.: New York, NY, 1981.
29. S. Budavari, ed., *The Merck Index*, Eleventh Edition, Merck and Company, Inc., 1989.
30. H. G. Barth and J. W. Mays, *Modern Methods of Polymer Characterization*, John Wiley and Sons: New York, NY, 1991.
31. J. Mitchell, *Applied Polymer Analysis and Characterization*, Macmillan Publishing Co.: New York, NY, 1987.

32. W. Hofmann, *Rubber Technology Handbook*, Oxford University Press: Oxford, 1989.
33. R. Seymour, *Polymers for Engineering Applications*, ASM International.
34. M. Chanda and S. K. Roy, *Plastics Technology Handbook*, Marcel Dekker, Inc. 1987.
35. J. Charrier, *Polymeric Materials and Processing*, Oxford University Press: Oxford, 1991.
36. J. H. Groeger, L. M. Compton, and M. P. Davido, "Forensic Analysis of Degraded and Ruptured Fabric Reinforced Elastomeric Diaphragms for Large Valve Applications," Invited Paper for the Society of Plastics Engineers Annual Technical Conference, Boston, MA (May, 1995).
37. *Static Seals Maintenance Guide*, Electric Power Research Institute. Report, Palo Alto, CA: December 1994. Report TR-104749.
38. *Guidelines for Instrument Calibration Extension/ Reduction Programs*, Electric Power Research Institute, Palo Alto, CA: March 1994. Report TR-103335.
39. NUREG CR-1369, "Procedures Evaluation Checklist for Maintenance, Test, and Calibration Procedures."
40. Instrument Society of America, ISA-S75.13, *Method of Evaluating the Performance of Positioners with Analog Input Signals and Pneumatic Output*.
41. *The American Heritage Dictionary of the English Language*, Third Edition, Houghton Mifflin Company: Boston, MA, 1992.
42. Controls International, Inc., *Control Valve Handbook*, Second Edition, 1977.

EPRI

Electric Power Research Institute
3412 Hillview Avenue
P.O. Box 10412
Palo Alto, California 94303
800-313-EPRI
www.epri.com

About EPRI

Electricity is increasingly recognized as a key to societal progress throughout the world, driving economic prosperity and improving the quality of life. The Electric Power Research Institute delivers the science and technology to make the generation, delivery, and use of electricity affordable, efficient, and environmentally sound.

Created by the nation's electric utilities in 1973, EPRI is one of America's oldest and largest research consortia, with some 700 members and an annual budget of about \$500 million. Linked to a global network of technical specialists, EPRI scientists and engineers develop innovative solutions to the world's toughest energy problems while expanding opportunities for a dynamic industry.

EPRI. Powering Progress

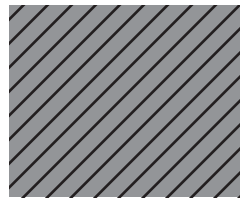

(continued from front cover)

4. TERM AND TERMINATION

This license and this agreement are effective until terminated. You may terminate them at any time by destroying this report. EPRI has the right to terminate the license and this agreement immediately if you fail to comply with any term or condition of this agreement. Upon any termination you may destroy this report, but all obligations of nondisclosure will remain in effect.

5. DISCLAIMER OF WARRANTIES AND LIMITATION OF LIABILITIES

NEITHER EPRI, ANY MEMBER OF EPRI, ANY COSPONSOR, NOR ANY PERSON OR ORGANIZATION ACTING ON BEHALF OF ANY OF THEM:

(A) MAKES ANY WARRANTY OR REPRESENTATION WHATSOEVER, EXPRESS OR IMPLIED, (I) WITH RESPECT TO THE USE OF ANY INFORMATION, APPARATUS, METHOD, PROCESS OR SIMILAR ITEM DISCLOSED IN THIS REPORT, INCLUDING MERCHANTABILITY AND FITNESS FOR A PARTICULAR PURPOSE, OR (II) THAT SUCH USE DOES NOT INFRINGE ON OR INTERFERE WITH PRIVATELY OWNED RIGHTS, INCLUDING ANY PARTY'S INTELLECTUAL PROPERTY, OR (III) THAT THIS REPORT IS SUITABLE TO ANY PARTICULAR USER'S CIRCUMSTANCE; OR

(B) ASSUMES RESPONSIBILITY FOR ANY DAMAGES OR OTHER LIABILITY WHATSOEVER (INCLUDING ANY CONSEQUENTIAL DAMAGES, EVEN IF EPRI OR ANY EPRI REPRESENTATIVE HAS BEEN ADVISED OF THE POSSIBILITY OF SUCH DAMAGES) RESULTING FROM YOUR SELECTION OR USE OF THIS REPORT OR ANY INFORMATION, APPARATUS, METHOD, PROCESS OR SIMILAR ITEM DISCLOSED IN THIS REPORT.

6. EXPORT

The laws and regulations of the United States restrict the export and re-export of any portion of this report, and you agree not to export or re-export this report or any related technical data in any form without the appropriate United States and foreign government approvals.

7. CHOICE OF LAW

This agreement will be governed by the laws of the State of California as applied to transactions taking place entirely in California between California residents.

8. INTEGRATION

You have read and understand this agreement, and acknowledge that it is the final, complete and exclusive agreement between you and EPRI concerning its subject matter, superseding any prior related understanding or agreement. No waiver, variation or different terms of this agreement will be enforceable against EPRI unless EPRI gives its prior written consent, signed by an officer of EPRI.

TR-107412R1



Printed on
Recycled Paper
Printed in USA