

# VALVE ACCESSORIES

SAMSON



Limit Switches · Solenoid Valves  
Pneumatic Lock-up Valves · Supply Pressure Regulators  
Volume Boosters · Quick Exhaust Valves · Applications

**SMART IN FLOW CONTROL**

# OUR EXPERTISE FOR YOU

## Expertise in valve engineering



Founded in 1907, SAMSON has since become a worldwide leader in the manufacture of expertly engineered control valves, positioners and other valve accessories for all industrial processes.

SAMSON has over 50 subsidiaries, amongst them noted manufacturers of special valves, such as AIR TORQUE, CERA SYSTEM, LEUSCH, PFEIFFER, RINGO VÁLVULAS, SED, STARLINE and VETEC.

With our subsidiaries, we are represented in over 80 countries to assist our customers on all continents.

SAMSON provides you with valve engineering and customer service from a single source:

- We support you in planning new installations or overhauling and expanding existing plants.
- We assist you in selecting and configuring the right equipment to suit your control requirements.
- We are close at hand to support your life cycle management, from installation and start-up to maintenance and service.



## Valve accessories for a wide variety of requirements

Together with valve accessories, control valves serve as engineered solutions for special applications. SAMSON has been developing and manufacturing high-quality valves, actuators and valve accessories for over 100 years. Thanks to our experience and expertise as well as customer requirements, we have continuously developed the individual components and optimized their interaction. Our engineering experts actively work to find the best solution for our valve assemblies.

Linear and rotary valves require different mounting kits, for example to attach solenoid valves, limit switches or lock-up valves. SAMSON valve accessories are designed with interfaces which make them easy to mount and that are rugged in design.

Most of our valve accessories are available in different versions to allow their functions to be adapted to a wide variety of requirements, such as use in potentially explosive atmospheres. We offer valve accessories which meet explosion protection requirements with their national and international certification.

### **Functional safety**

All safety-related data of any SAMSON valve accessories suitable for use in safety-instrumented systems according to IEC 61508 are documented in safety manuals.

# LIMIT SWITCHES

## Functional principle and use



Limit switches are suitable for automation of on/off applications and issue an electric binary signal when the valve travel exceeds or falls below an adjusted limit. The signal can be used, for example for switching control signals, issuing visual and audible alarms or for connection to central control or alarm systems.

The installed limit contacts are either inductive, electric, pneumatic or software-based, depending on the device version.

The contacts, which can be overridden for the most part, can be used either as normally open contacts or normally closed contacts. SAMSON limit switches can contain up to three limit contacts, depending on the version.

**Attachment** – The limit switches can be attached to linear or rotary actuators or directly to pneumatic or electropneumatic positioners depending on the control valve assembly. The limit switch is linked axially over the shaft in rotary actuators or linked using a lever in linear actuators.

**Safety** – Valves are used to isolate or open pipelines in safety-instrumented systems. The Type 4747 Limit Switch can execute the safety function by performing the safety-related end position monitoring and emergency venting. An optionally integrated solenoid valve can be used for emergency venting. In this case, the limit switch discharges its pneumatic output to the atmosphere when the solenoid valve is de-energized, causing the mounted actuator to be vented.

The function is suitable for use in safety-instrumented systems. The Type 4747 can be used up to SIL 2 (single device) and SIL 3 (redundant configuration) observing the requirements of IEC 61511 and the required hardware fault tolerance.



**Explosion protection** – Particularly processes where a potentially explosive atmospheres can form require plant components that meet special explosion protection requirements.

For the use in explosive atmospheres, we offer limit switches with intrinsic safety (Ex i), in flameproof enclosures (Ex d) and non-sparking design (Ex nA).

Type	3738-20	3738-50	3768	3776	4740	4744	4746	4747
Without explosion protection	■	■	■	■	■		■	■
Intrinsic safety	■	■	■	■			■	■
Flameproof enclosure						■		■
Non-sparking equipment	■		■	■			■	■

**Communication** – SAMSON limit switches with communication capabilities can be integrated into process control and asset management systems. The Type 3738-50 Electronic Limit Switch supports FOUNDATION™ fieldbus and is efficiently powered by the fieldbus network. The Type 3776 Limit Switch has an optional AS-Interface module with bus connection for wire breakage or short-circuit monitoring.

**Diagnostics** – In safety-instrumented systems, it is essential that the valve responds on demand and fully opens to allow the medium to flow through it or closes to shut off the medium flow within a certain time. To check whether the valve can move on demand, the Type 3738 Electronic Limit Switch performs a partial stroke test.

# LIMIT SWITCHES



Type 4744



Type 4746  
Electric limit contacts



Type 4746  
Pneumatic limit contacts



Type 4747

## Limit switches without solenoid valve

Type		4744	4746	4747
Attachment	Direct attachment to SAMSON actuators			■
	NAMUR	■	■	■
	VDI/VDE 3845			■
	Direct attachment to positioners		Type 4763/4765	
Max. number of contacts		2	2	2
Type of protection		Ex d	Ex ia	Ex d, Ex i, Ex n
Safety function (SIL)			■ <sup>1)</sup>	■
Permissible ambient temperature <sup>2)</sup>		-20 to +75 °C	-20 to +100 °C	-40 to +80 °C
Low temperature range <sup>2)</sup>		-55 to +70 °C	-50 to +100 °C	-
Connecting thread		-	G/NPT	-
Cable entry		M20x1.5	M20x1.5	M20x1.5/½ NPT

<sup>1)</sup> Applies to the proximity switches used in the inductive version as stated in manufacturer's declaration HE-1088

<sup>2)</sup> Max. temperature range, restrictions possible depending on the version.  
The limits in the type examination certificate additionally apply to explosion-protected versions.



Type 3738



Type 3768



Type 3776



Type 4740

## Limit switches with optional solenoid valve

Type		3738	3768	3776	4740
Attachment	Direct attachment to SAMSON actuators		■	■	– <sup>1)</sup>
	NAMUR	■	■	■	
	VDI/VDE 3845	■	■	■	
	Direct attachment to positioners				
Max. number of contacts		3	2	3	2
Type of protection		Ex i, Ex n	Ex i, Ex n	Ex i, Ex n	–
Safety function (SIL)			■ <sup>2)</sup>	■	
Permissible ambient temperature <sup>3)</sup>		–25 to +80 °C	–20 to +80 °C	–20 to +80 °C	–20 to +65 °C
Low temperature range <sup>3)</sup>		–40 to +80 °C	–45 to +80 °C	–45 to +80 °C	–
Connecting thread		G/NPT	G/NPT	G/NPT	G
Cable entry		M20x1.5	M20x1.5	M20x1.5	M20x1.5

<sup>1)</sup> Attachment to Type 3353 Angle Seat Valve, Type 3354 Globe Valve, Type 3379 Pneumatic Actuator

<sup>2)</sup> Applies to the proximity switches used in the inductive version as stated in manufacturer's declaration HE-1088

<sup>3)</sup> Max. temperature range, restrictions possible depending on the version.  
The limits in the type examination certificate additionally apply to explosion-protected versions.

# SOLENOID VALVES

## Functional principle and use



Solenoid valves serve as switching elements for the opening and closing of the valve assembly or act as safety control circuits for connected valve accessories to form the interface between the electric control level and the pneumatic actuator.

SAMSON solenoid valves are characterized by their high level of operational reliability and minimal power consumption. The Type 3969 Solenoid Valve also operates without consuming air and is a particularly energy-efficient solution. Depending on the solenoid valve version, 3/2-way, 5/2-way, 5/3-way or 6/2-way functions can be implemented.

SAMSON solenoid valves are available with either Whitworth pipe threads (G) or threads according to national pipe thread standards (NPT).

**Attachment** – Numerous types of attachment are available for SAMSON solenoid valves. In addition to direct attachment to linear actuators according to IEC 60534-6 (NAMUR) and rotary actuators according to VDI/VDE 3845 or 3847, the solenoid valves can be mounted on rails or walls.

**Safety** – The solenoid valves meet high quality requirements and are suitable for use in safety-instrumented systems up to SIL 3 (redundant configuration) observing the requirements of IEC 61511 and the required hardware fault tolerance.

In safety-instrumented systems, solenoid valves are often used in redundant setups. In this way, if one solenoid valve fails, the fail-safe action of the actuator is still guaranteed by a second solenoid valve. SAMSON has designed a redundancy plate for this version to allow two solenoid valves to be connected in series or in parallel without any additional hook-up. The solenoid valves are mounted on the left and right side to the NAMUR interfaces of the redundancy plate.

**SAMSON modular design** – The accessories for SAMSON solenoid valves are designed according to the modular principle. Such accessories include various adapter plates, double-axial adapters and restrictor plates as well as special constructions. They allow the solenoid valves to be adapted to meet a wide variety of requirements.





**Explosion protection** – The switching function in the solenoid valves is performed by an electro-pneumatic binary converter, which has proven reliable in service a million times over. Thanks to

its low power consumption, the type of protection intrinsic safety (Ex i) is possible. Further available types of protection include flameproof enclosure (Ex d) and non-sparking equipment (Ex n).

Type	3963	3966	3967	3969
Without explosion protection	■	■	■	■
Intrinsic safety Ex i	■	■	■	■
Flameproof enclosure Ex d		■		
Non-sparking equipment Ex n	■	■	■	

## Emergency venting

The hook-up consists of a pneumatic actuator with positioner, limit switch and solenoid valve for emergency venting of the actuator. The signal issued by the limit switch when the valve travel exceeds or falls below an adjusted limit can be used to activate the solenoid valve.

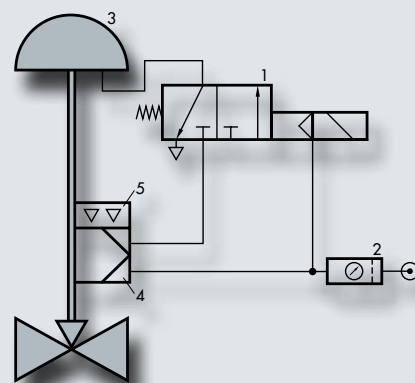

- 1 Solenoid valve
- 2 Supply pressure regulator
- 3 Control valve
- 4 Positioner
- 5 Limit switch

# SOLENOID VALVES



Type 3963



Type 3966



Type 3967



Type 3969

Type		3963	3966	3967	3969
Switching function	3/2	■	■	■	■
	5/2	■		■	
	6/2	■			
	5/3	■		■	
Attachment	Direct attachment to actuators <sup>1)</sup>	■	■	■	■
	Hooked up as required	■	■	■	■
	NAMUR	■	■	■	■
	VDI/VDE 3845	■	■	■	■
Type of protection		Ex i, Ex n	Ex i, Ex n, Ex d	Ex i, Ex n	Ex i
Safety function (SIL)		■		■	■
Flow coefficient $K_{vs}$		0.16 to 4.3	0.9	0.32 to 4.3	0.32 to 4.3
Supply pressure		Max. 6 bar	Max. 10 bar	Max. 10 bar	Max. 10 bar
Permissible ambient temperature <sup>2)</sup>		-20 to +80 °C	-20 to +80 °C	-20 to +80 °C	-20 to +80 °C
Low temperature range <sup>2)</sup>		-45 to +80 °C	-45 to +80 °C	-45 to +80 °C	-45 to +80 °C
Connecting thread		G/NPT	G/NPT	G/NPT	G/NPT

<sup>1)</sup> Mounting on a connection block with positioner for SAMSON Type 3277 Pneumatic Actuator

<sup>2)</sup> Max. temperature range, restrictions possible depending on the version.  
The limits in the type examination certificate additionally apply to explosion-protected versions.

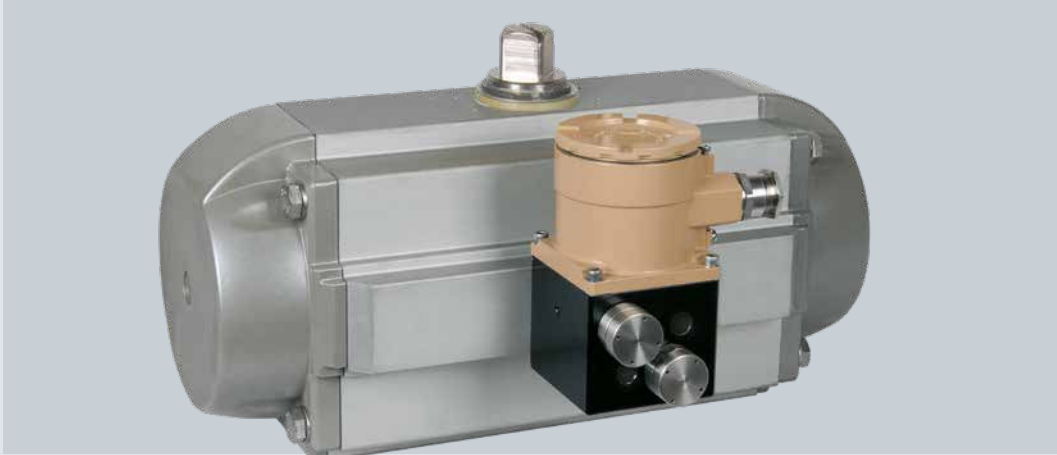

## Hook-ups

**On/off service** – On/off applications can be implemented by a solenoid valve as the single mounted device on the valve assembly. An additional external pilot supply is not required for this hook-up since the pilot supply is fed internally to the solenoid valve.

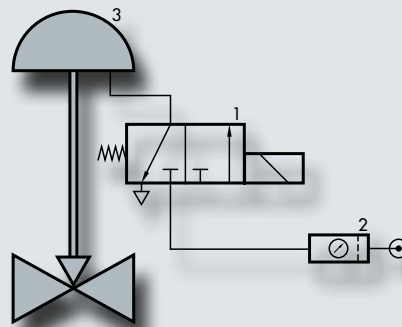

- 1 Solenoid valve
- 2 Supply pressure regulator
- 3 Control valve

**In combination with a positioner** – In combination with a positioner, the solenoid valve provides additional emergency shutdown to extend the control function of the valve assembly. In this case, the solenoid valve is connected directly upstream of the actuator.

In the event of emergency, the solenoid valve ensures that the actuator is vented and moves to the fail-safe position. In throttling service, an external pilot supply of the solenoid valve is always necessary.

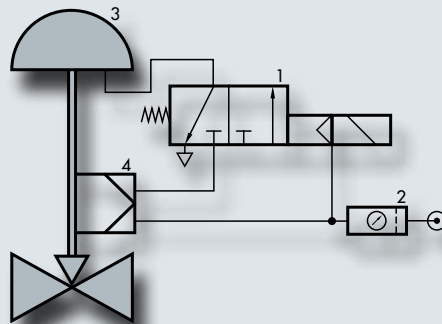

- 1 Solenoid valve
- 2 Supply pressure regulator
- 3 Control valve
- 4 Positioner

# LOCK-UP VALVES

## Functional principle and use



Lock-up valves are used to shut off the signal pressure line of pneumatic actuators. They shut off the line either when the air supply falls below an adjusted limit or in case of complete air supply failure. This causes the actuator to fail in place.

The SAMSON Type 3709 Pneumatic Lock-up Valve is available in various versions for different types of attachment and flow coefficients. All versions have an easily accessible adjustment screw for fine tuning the switching point.

All versions are available either in stainless steel or aluminum.

Type 3709	-01	-02	-04	-05	-06 <sup>1)</sup>	-07	-08 <sup>1)</sup>	-12 <sup>1)</sup>	-13 <sup>1)</sup>
Direct attachment to positioners	■								
Hooked up as required		■	■					■	
Attachment on a solenoid valve						■	■		
Attachment according to VDI/VDE 3845 (rotary actuators)				■	■	■	■		■
Single-acting	■	■	■	■	■	■	■		
Double-acting								■	■
Max. supply pressure (bar)	12	12	6	6	6	6	6	6	6
Flow coefficient $K_{Vs}$	0.2	0.2	4.3	2.0	4.3	2.0	4.3	4.3	4.3
Permissible ambient temperature	-25 to +80 °C		-40 to +80 °C						
Connecting thread	G/NPT								

<sup>1)</sup> On request



## Compact hook-ups

**Standard application** – The pneumatic lock-up valve is mounted between the positioner and actuator.

**Recommended models** – Type 3709-1 for direct attachment to the positioner. This version is particularly compact and uses minimum piping.

**In combination with a solenoid valve** – The required function determines in which sequence the devices are mounted on the valve assembly. The pneumatic lock-up valve is mounted between the actuator and solenoid valve in the example shown. In this case, the lock-up function has priority over the fail-safe action triggered by the solenoid valve.

**Recommended models** – Types 3709-7 and 3709-8 for compact sandwich-style attachment in combination with rotary actuators. The pneumatic lock-up valve is mounted between the solenoid valve and actuator without the need for any piping.

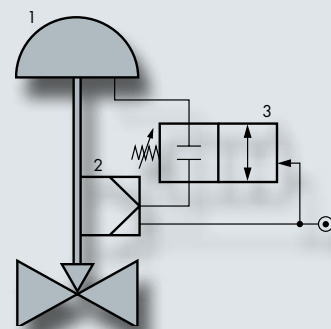

- 1 Actuator
- 2 Positioner
- 3 Pneumatic lock-up valve

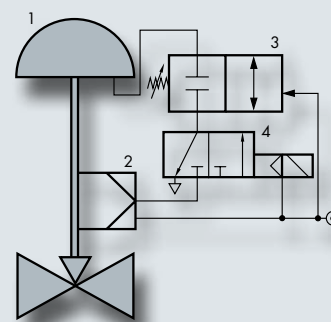

- 1 Actuator
- 2 Positioner
- 3 Pneumatic lock-up valve
- 4 Solenoid valve

# SUPPLY PRESSURE REGULATORS

## Functional principle and use



The Type 4708 Supply Pressure Regulator can be used in a wide variety of applications. The regulator is quick and easy to adjust at the adjustment screw. Low-temperature versions for use down to  $-50\text{ }^{\circ}\text{C}$  are available for some device versions.

Our supply pressure regulators can be equipped with a filter receptacle and a pressure gauge on the outlet side. The pressure gauges are available entirely made of stainless steel (therefore completely free of any copper alloy) or with a stainless steel housing and brass measuring element.

Supply pressure regulators are used to provide pneumatic measuring and control equipment with a constant supply pressure. They reduce and control the pressure of a compressed air network to the pressure adjusted at the set point adjuster.

The body is available either in aluminum or stainless steel.

Type	4708-1x	4708-45	4708-5x	4708-6x
Installation into the pipeline as required	■	■		
Direct attachment to positioners			■	
Direct attachment to SAMSON actuators				■
Supply pressure regulator with increased air capacity		■		
Supply pressure Max.	12 bar	12 bar	12 bar	12 bar
Mesh size of filter cartridge	20 $\mu\text{m}$ <sup>1)</sup>	15 $\mu\text{m}$ <sup>1)</sup>	20 $\mu\text{m}$ <sup>1)</sup>	20 $\mu\text{m}$ <sup>1)</sup>
Set point range	0.2 to 1.6 bar/0.5 to 6 bar			
Permissible ambient temperature <sup>2)</sup>	$-50$ to $+80\text{ }^{\circ}\text{C}$			
Connecting thread	G/NPT			

<sup>1)</sup> Also available with 5  $\mu\text{m}$  mesh size (e.g. for SIL applications)

<sup>2)</sup> Max. temperature range, restrictions possible depending on the version.



## Versatile in use

The wide variety of options for the Type 4708 makes it suitable for use in various fields of application:

### Supply pressure regulators with continuously adjustable set point range

- Types 4708-10 to -17: supply pressure regulators for installation in the pipeline as required
- Type 4708-45: supply pressure regulator with increased air capacity
- Types 4708-53 to -55: supply pressure regulators for direct attachment to various positioners
- Types 4708-62 and -64: supply pressure regulators for direct attachment to Type 3277 and Type 3372 Pneumatic Actuators
- Types 4708-65 and -66: Supply pressure regulators for direct attachment to Type 3379 Pneumatic Actuator

### Further versions

- Type 4708-82: manual/automatic switchover functioning as a pneumatic bypass for positioners
- Types 4708-83 to -87: compressed air filters



Type 4708-12

Type 4708-45

Type 4708-53

Type 4708-64



Type 4708-82 with cover

Type 4708-82 without cover

# VOLUME BOOSTERS

## Functional principle and use



Volume boosters are used together with positioners to increase the positioning speeds of pneumatic actuators. They influence the process to

vent or fill the actuator with air, which causes the control valve to open or close more quickly.

The Type 3755 Pneumatic Volume Booster features a linear characteristic and an ideal boost ratio. It can be quick and easily adapted to the specific application at the bypass screw which can be lead-sealed.

The low-temperature version can be used at ambient temperatures down to  $-55\text{ }^{\circ}\text{C}$ . Type 3755-2 is fitted with an additional flange with a threaded exhaust port to discharge the exhaust air through a pipe or to feed it back for purging of the actuator spring chamber. This version is available either in stainless steel or aluminum.

Type	3755-1	3755-2
Adjustable bypass restriction	■	■
Hooked up as required	■	■
Sintered polyethylene filter disk for noise reduction	■	
Flanged-on threaded exhaust port		■
Low-temperature version	■	■
$K_{vs}$ (exhaust and supply)	2.5	2.5
Pressure ratio: signal to output	1:1	
Permissible ambient temperature	Standard	$-40$ to $+80\text{ }^{\circ}\text{C}$
	Low-temperature version	$-55$ to $+60\text{ }^{\circ}\text{C}$
Connecting thread	G/NPT	



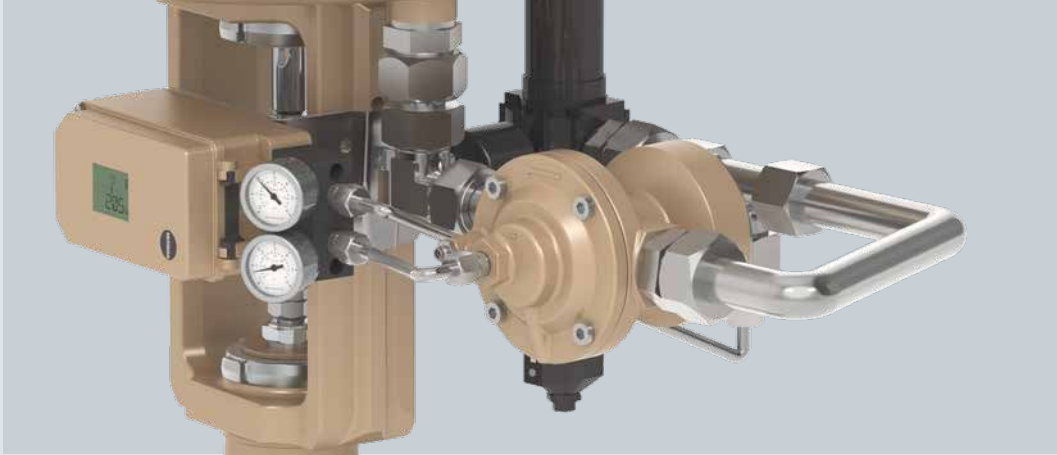

## Hook-ups

**Standard application** – Normally, the volume booster is mounted between the positioner and actuator. To filter the supply air and keep the supply pressure constant, the air is fed to the booster through a supply pressure regulator. This way, the volume booster supplies the actuator with an air flow output whose pressure corresponds exactly to the signal pressure of the positioner, except that it has a much higher volume.

**In combination with a solenoid valve** – A solenoid valve can be mounted between the volume booster and actuator. In this case, the solenoid valve must be large enough to use the full air capacity of the volume booster.

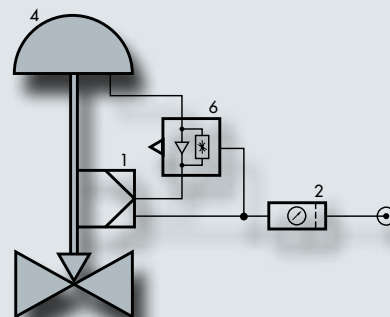

- 1 Positioner
- 2 Supply pressure regulator
- 4 Control valve (fail-close)
- 6 Pneumatic volume booster

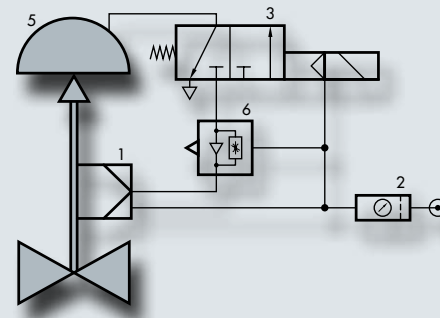

- 1 Positioner
- 2 Supply pressure regulator
- 3 Solenoid valve
- 5 Control valve (fail-open)
- 6 Pneumatic volume booster

# QUICK EXHAUST VALVES

## Functional principle and use



Quick exhaust valves are used to reduce the time required for venting pneumatic actuators.

The Type 3711 Quick Exhaust Valve features a particularly compact design and a high flow coefficient. The integrated restriction allows the response of the valve to be adjusted to meet the requirements of the application.

If required, the exhaust air can be discharged through a pipe and, for example fed back for purging of the actuator spring chamber.

Type 3711	
Operating pressure	0 to 7 bar
$K_{vs}$ (exhaust)	10.0 <sup>1)</sup>
Permissible ambient temperature	-40 to +80 °C
Permissible leakage at 6 bar	≤ 25 l/h
Connecting thread	G/NPT <sup>2)</sup>

<sup>1)</sup> Without silencer

<sup>2)</sup> With adapter

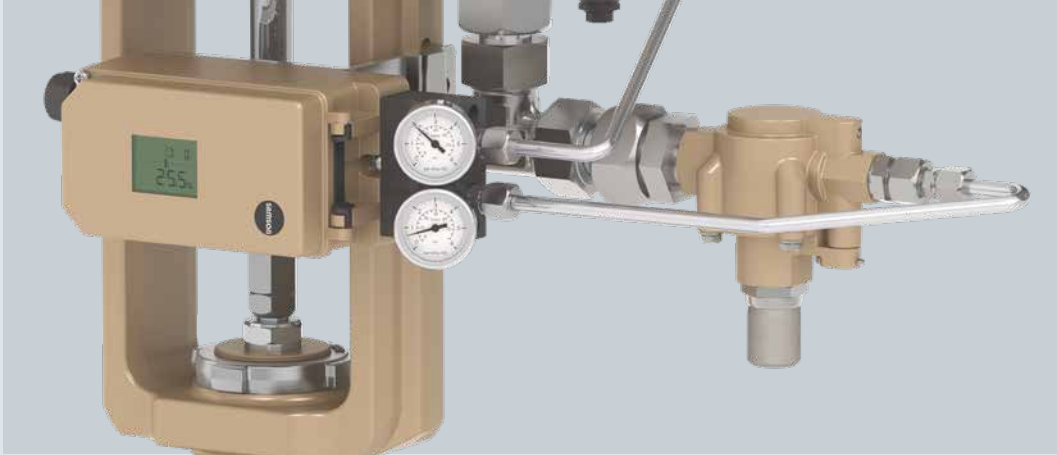

## Adjustable response behavior

The quick exhaust valve is mounted between the positioner or solenoid valve and the pneumatic actuator. It is used to accelerate the venting capacity to vent the pneumatic actuator more quickly.

The example shows a standard hook-up with activation by a positioner and an additional solenoid valve connected between the positioner and quick exhaust valve.

The integrated restriction allows the response behavior to be tuned optimally to adapt the Type 3711 Quick Exhaust Valve to individual valve assemblies and their control behavior. For example, opening the restriction causes the quick exhaust valve to intervene in the closed-loop control after large signal changes occur. This counteracts overshooting, especially in response to small signal changes. A cotter pin secures the restriction setting.

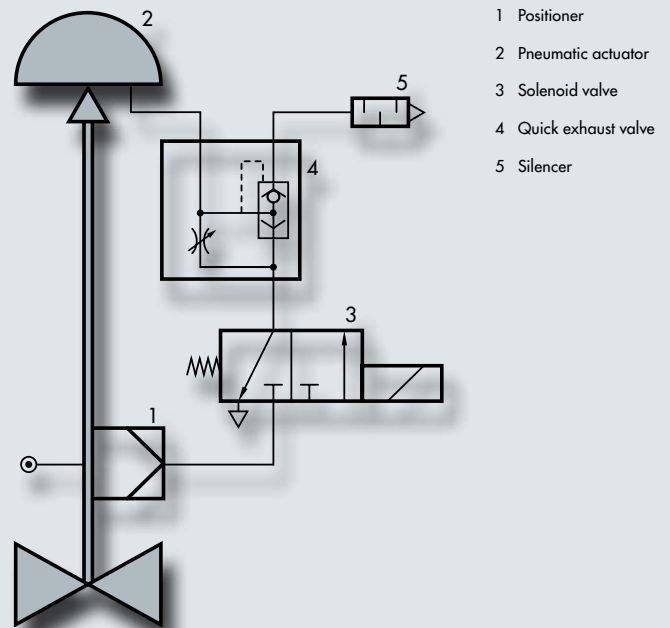

# APPLICATIONS

## Hook-ups

In addition to the wide variety of high-quality products in our program, we also offer control engineering for the entire valve assembly. You can benefit from our expertise.

Valve accessories are hooked up to achieve the required function of the valve assembly. At SAMSON, we have already implemented over 500 different hook-ups that have proven reliable in field use.

Our engineering specialists rely on proven compact hook-ups for standard applications to avoid complicated piping wherever possible. This results in cost-optimized solutions and the best possible control performance since signal transit times are minimized.

While a compact design is aimed for in standard applications, an absolutely reliable engineering to achieve the best possible interaction between all components is necessary for special applications and to meet complex requirements. Conditions, specifications and the features of the devices used are combined to form dependable valve assemblies.

To create assemblies that meet the control requirements, we can rely on the extensive product portfolio of SAMSON and its subsidiaries as well as specifically developed software tools to simulate the transit times and control behavior beforehand.

Test benches to verify the required properties on the mounted valves round off the engineering expertise provided by SAMSON.

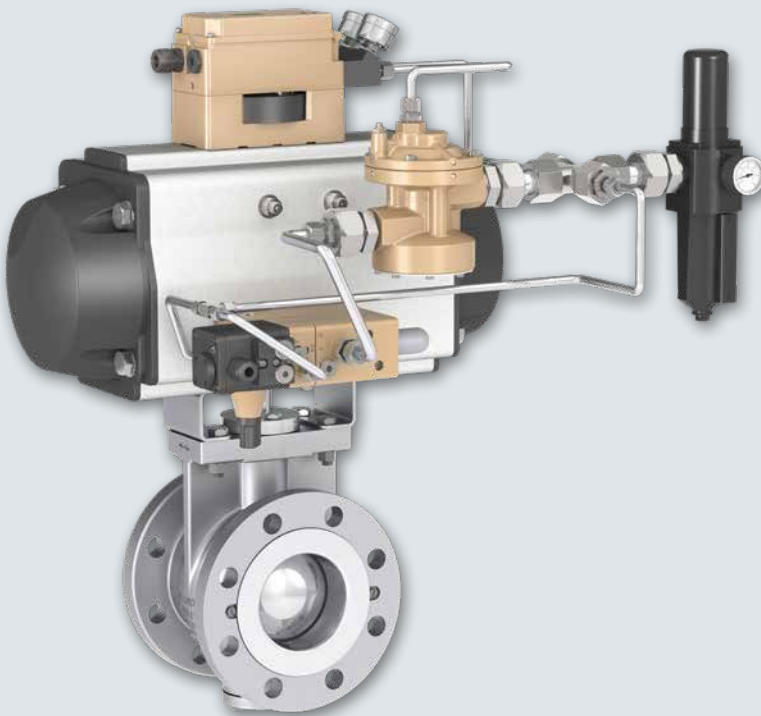

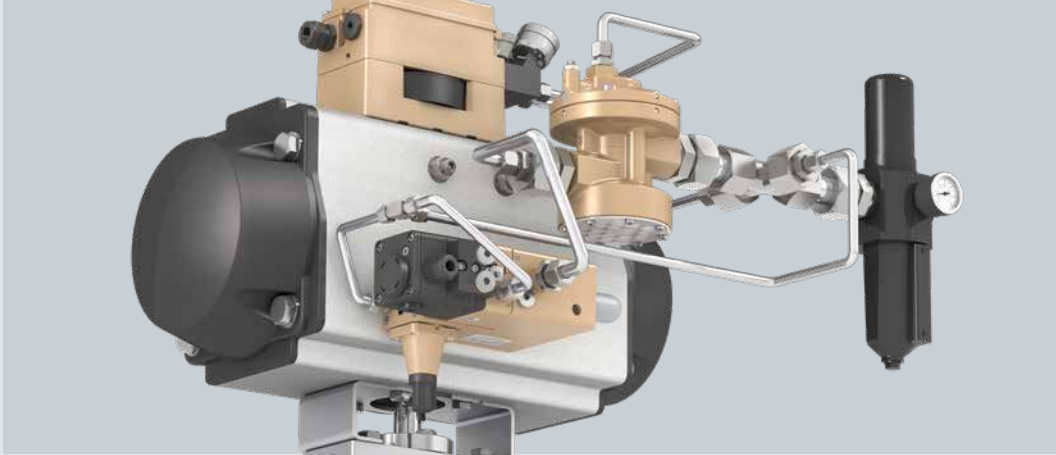

## Lock-up function with priority

The example shows a valve assembly for control, with quick-acting shut-off and fail-in-place functions. As the last device connected upstream of the actuator, the pneumatic lock-up valve takes priority. Regardless of the positioner's signal and the solenoid valve's position, the pneumatic lock-up valve causes the actuator to remain in its last position as soon as the supply pressure falls below a certain limit.

The opening and closing action is accelerated by the volume booster, which boosts the positioner's control signal accordingly. When using the Type 3755 Volume Booster, it supplies the actuator with an air flow output whose pressure corresponds exactly to the signal pressure of the positioner, except that it has a much higher volume.

The quick-acting shut-off function is performed by the solenoid valve, which is activated by the volume booster in the example. The supply pressure regulator provides the devices in the hook-up with a constant supply pressure.

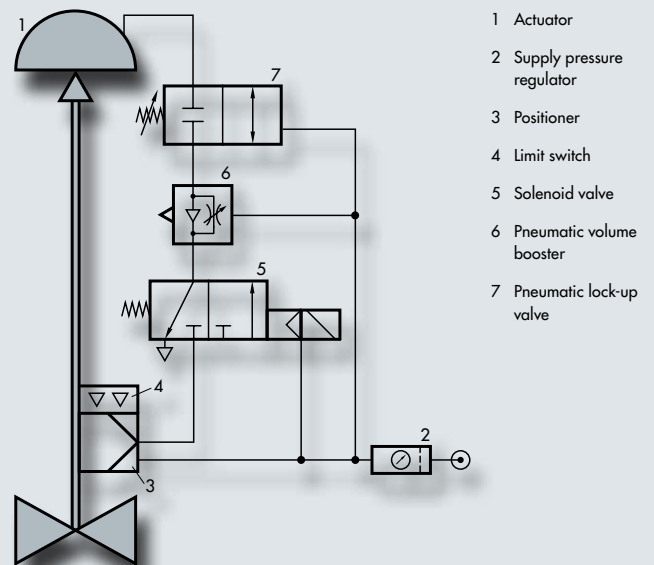

# APPLICATIONS

## Anti-surge valves

Anti-surge valves, which serve as safety equipment for compressors, must meet complex requirements.

Achieving a control valve assembly with excellent control properties and fast positioning times poses a special engineering challenge. For example, the valve must be able to move to its fail-safe position in under one second. In addition, requirements concerning controlled positioning times and control accuracy make it necessary to use valve accessories tailored to the application and their intricate hook-up. It is therefore no surprise that our anti-surge valves are predominantly customized one-off solutions.

To achieve the best possible control properties, we recommend using the Type 3755 Volume Booster.

**Compressors** are used to feed gases in chemical and petrochemical processes. A change in the operating conditions can cause dynamic instability, often referred to as surging. This critical state is characterized by a periodic reversal of the flow direction. Surging can damage or even destroy the compressor within a very short period of time. Anti-surge valves are used to protect the compressor against damage and malfunction.

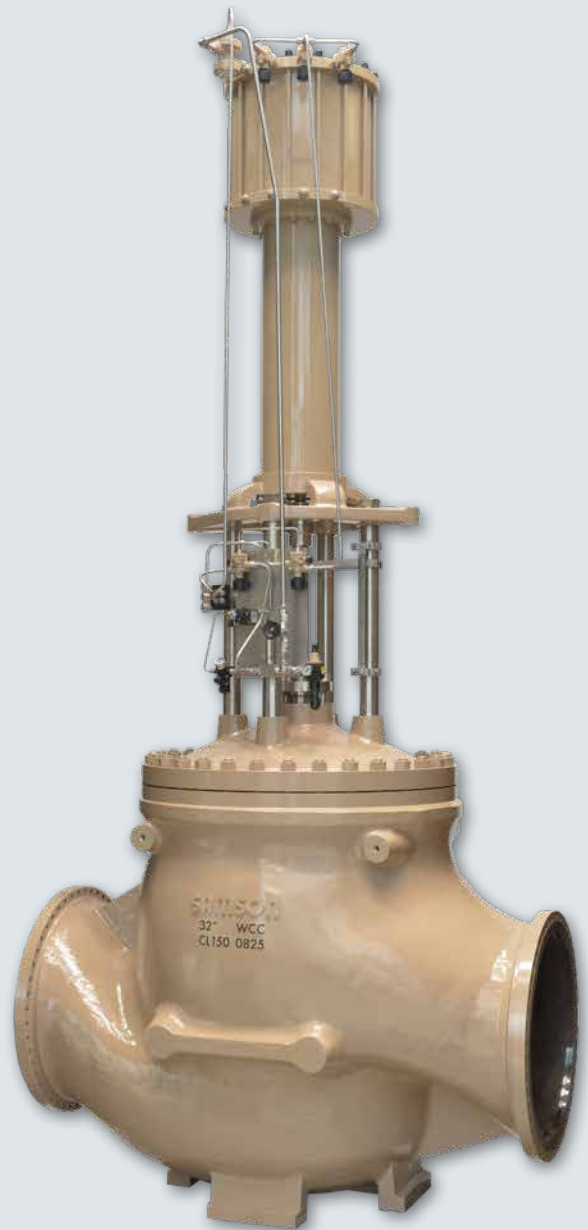



## Adjustable closing time

The example shows a valve assembly for control with adjustable closing time and quick opening function.

By using two volume boosters, the opening time of the control valve, in particular, is accelerated. The closing time can be adjusted within a certain range at a separate restriction.

The solenoid valve activates the two connected volume boosters to implement the quick opening function. When the solenoid valve is energized, the control valve is in closed-loop control: the positioner supplies both volume boosters with a control signal, which is boosted accordingly. The supply pressure regulator supplies a constant supply pressure.

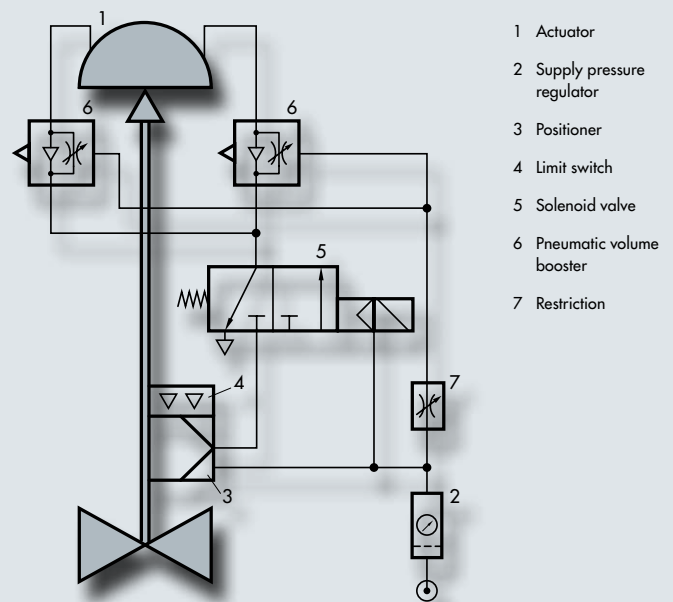

### Benefit from our know-how

- We optimally tune the entire valve assembly to various conditions.
- We adapt hook-ups to suit the requirements and valve size.
- We support you in finding the best control valve setup for your application.

# SAMSON AT A GLANCE



## STAFF

- Worldwide 4,500
- Europe 3,700
- Asia 600
- Americas 200
- Frankfurt am Main, Germany 2,000

## INDUSTRIES AND APPLICATIONS

- Chemicals and petrochemicals
- Food and beverages
- Pharmaceuticals and biotechnology
- Oil and gas
- Liquefied Natural Gas (LNG)
- Marine equipment
- Power and energy
- Industrial gases
- Cryogenic applications
- District energy and building automation
- Metallurgy and mining
- Pulp and paper
- Water technology
- Other industries

## PRODUCTS

- Valves
- Self-operated regulators
- Actuators
- Positioners and valve accessories
- Signal converters
- Controllers and automation systems
- Sensors and thermostats
- Digital solutions

## SALES SITES

- More than 50 subsidiaries  
in over 40 countries
- More than 200 representatives

## PRODUCTION SITES

- SAMSON Germany, Frankfurt, established in 1916  
Total plot and production area: 150,000 m<sup>2</sup>
- SAMSON France, Lyon, established in 1962  
Total plot and production area: 23,400 m<sup>2</sup>
- SAMSON Turkey, Istanbul established in 1984  
Total plot and production area: 11,053 m<sup>2</sup>
- SAMSON USA, Baytown, TX, established in 1992  
Total plot and production area: 9,200 m<sup>2</sup>
- SAMSON China, Beijing, established in 1998  
Total plot and production area: 10,138 m<sup>2</sup>
- SAMSON India, Pune district, established in 1999  
Total plot and production area: 18,000 m<sup>2</sup>
- SAMSON Russia, Rostov-on-Don, established in 2015  
Total plot and production area: 5,000 m<sup>2</sup>
- SAMSON AIR TORQUE, Bergamo, Italy  
Total plot and production area: 27,684 m<sup>2</sup>
- SAMSON CERA SYSTEM, Hermsdorf, Germany  
Total plot and production area: 14,700 m<sup>2</sup>
- SAMSON KT-ELEKTRONIK, Berlin, Germany  
Total plot and production area: 1,060 m<sup>2</sup>
- SAMSON LEUSCH, Neuss, Germany  
Total plot and production area: 18,400 m<sup>2</sup>
- SAMSON PFEIFFER, Kempen, Germany  
Total plot and production area: 35,400 m<sup>2</sup>
- SAMSON RINGO, Zaragoza, Spain  
Total plot and production area: 18,270 m<sup>2</sup>
- SAMSON SED, Bad Rappenau, Germany  
Total plot and production area: 10,370 m<sup>2</sup>
- SAMSON STARLINE, Bergamo, Italy  
Total plot and production area: 26,409 m<sup>2</sup>
- SAMSON VDH PRODUCTS, the Netherlands
- SAMSON VETEC, Speyer, Germany  
Total plot and production area: 27,090 m<sup>2</sup>

## SAMSON AKTIENGESELLSCHAFT

Weismuellerstrasse 3 · 60314 Frankfurt am Main, Germany  
Phone: +49 69 4009-0 · Fax: +49 69 4009-1507  
E-mail: [samson@samsongroup.com](mailto:samson@samsongroup.com)  
Internet: [www.samsongroup.com](http://www.samsongroup.com)