

Performance Sheet			
Class		150LB	
Shell Test		3.0	
Water Test	Positive Seal Test	1.1	MPa
	Reverse Seal Test		
Air Test	Positive Seal Test	0.6	
	Reverse Seal Test		
Suitable Temperature		-29~120℃	
Suitable Medium		Water, Steam, Oil etc	

- Technical Standard
1. Design conform to API 609
 2. Face to face conform to API 609
 3. Flange dimension conform to ASME B16.5
 4. Test and inspect conform to API 598

12	Clamp Ring	ASTM A182 F316
11	Sealing Ring	ASTM A276 316+PTFE
10	Seat	Surfacing 316
9	Yoke	CS
8	Packing Gland	ASTM A216 WCB
7	Packing	PTFE
6	Upper Shaft	ASTM A564 630
5	Disc	ASTM A351 CF8M
4	Pin	ASTM A182 F316
3	Lower Shaft	ASTM A564 630
2	Body	ASTM A216 WCB
1	Lower Cover	ASTM A105
No	Parts Name	Parts Material

NPS	DN	L	ϕD	$\phi D1$	$\phi D2$	C	f	n- ϕd	4-M
12"	300	178	$\phi 485$	$\phi 431.8$	$\phi 381$	32.2	2	8- $\phi 26$	4-M24

Drawing NO:		BUTTERFLY VALVE	
D043F-150LB		150LB	
DRAWING BY	CHECKED BY	APPROVED BY	Date
D.Y.Z.	M.Z.H.	M.Z.H.	2021.05.12

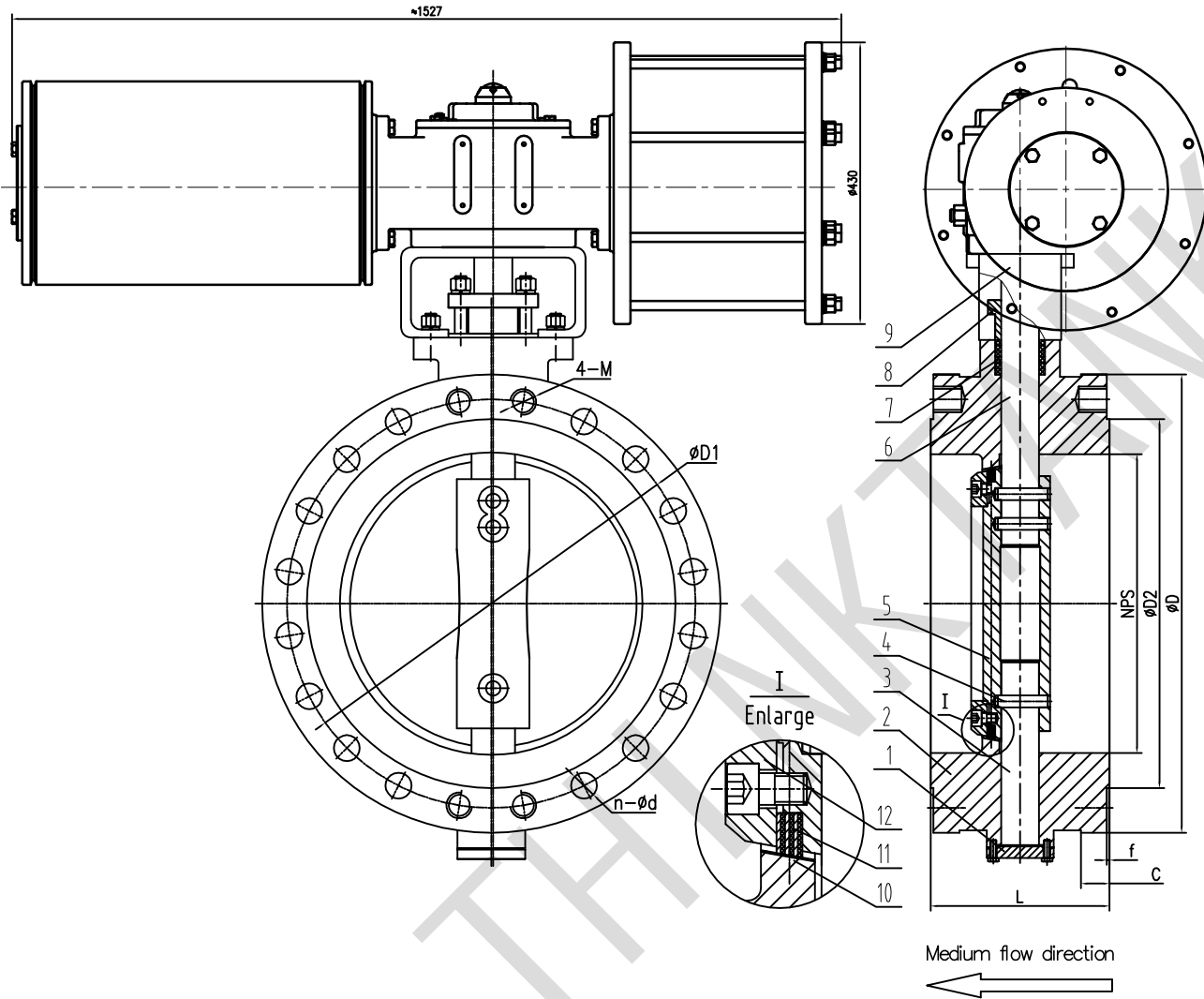

Performance Sheet			
Class		150LB	
Shell Test		3.0	
Water Test	Positive Seal Test	1.1	
	Reverse Seal Test	/	
Air Test	Positive Seal Test	0.6	
	Reverse Seal Test	/	
Suitable Temperature		-29~120℃	
Suitable Medium		Water, Steam, Oil etc	

- Technical Standard
1. Design conform to API 609
 2. Face to face conform to API 609
 3. Flange dimension conform to ASME B16.5
 4. Test and inspect conform to API 598

12	Clamp Ring	ASTM A182 F316
11	Sealing Ring	ASTM A276 316+PTFE
10	Seat	Surfacing 316
9	Yoke	CS
8	Packing Gland	ASTM A216 WCB
7	Packing	PTFE
6	Upper Shaft	ASTM A564 630
5	Disc	ASTM A351 CF8M
4	Pin	ASTM A182 F316
3	Lower Shaft	ASTM A564 630
2	Body	ASTM A216 WCB
1	Lower Cover	ASTM A105
No	Parts Name	Parts Material

NPS	DN	L	ØD	ØD1	ØD2	C	f	n-Ød	4-M
20"	500	229	Ø700	Ø635	Ø584.2	43.3	2	16-Ø33	4-M30

Drawing NO:		BUTTERFLY VALVE	
D043F-150LB		150LB	
DRAWING BY	CHECKED BY	APPROVED BY	Date
D.Y.Z.	M.Z.H.	M.Z.H.	2021.05.12

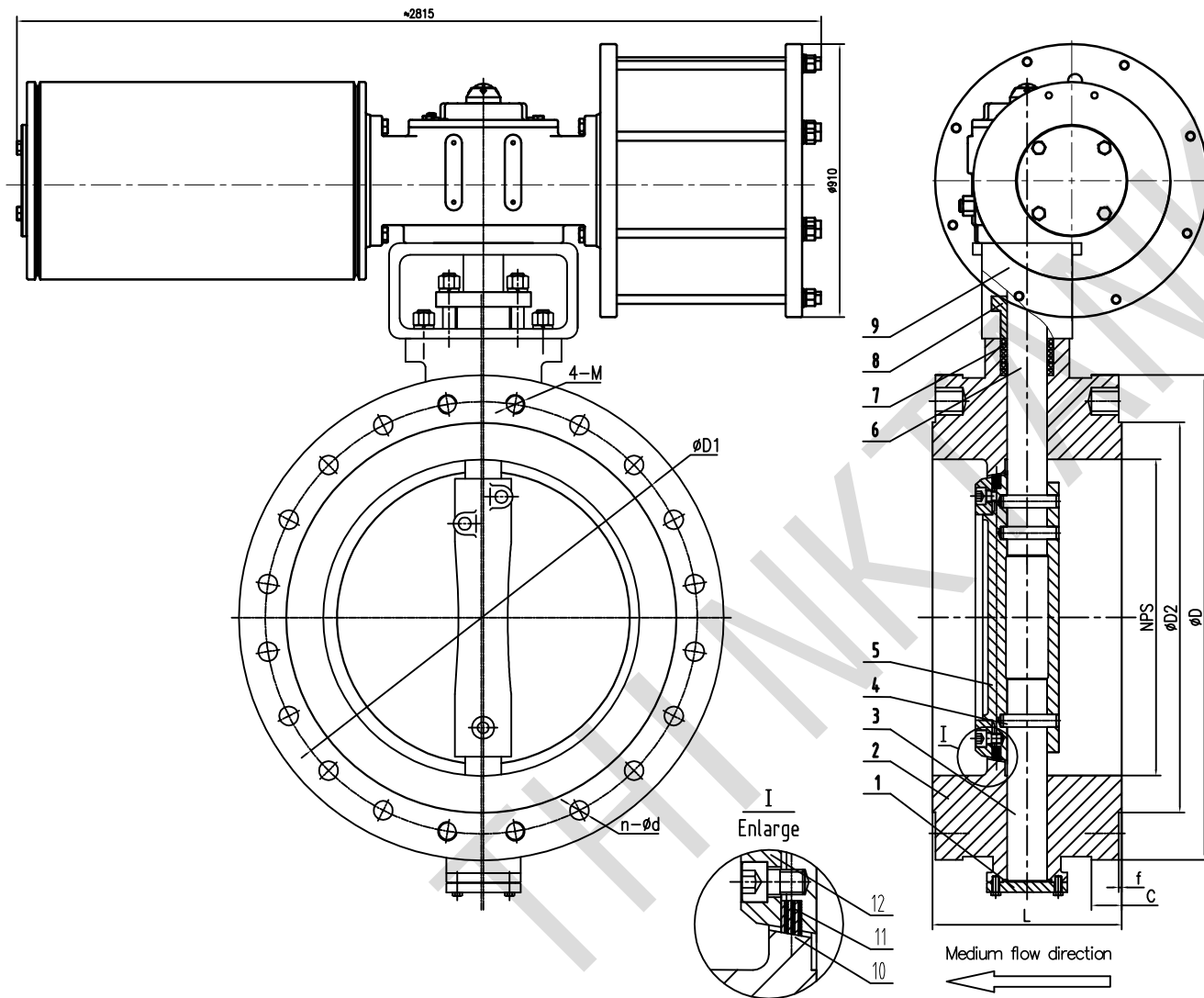

Performance Sheet			
Class		150LB	
Shell Test		3.0	
Water Test	Positive Seal Test	1.1	MPa
	Reverse Seal Test		
Air Test	Positive Seal Test	0.6	
	Reverse Seal Test		
Suitable Temperature		-29~120℃	
Suitable Medium		Water, Steam, Oil etc	

- Technical Standard
1. Design conform to API 609
 2. Face to face conform to API 609
 3. Flange dimension conform to ASME B16.47 A
 4. Test and inspect conform to API 598

12	Clamp Ring	ASTM A182 F316L
11	Sealing Ring	ASTM A276 316L+PTFE
10	Seat	ASYM A351 CF3M
9	Yoke	CS
8	Packing Gland	ASYM A351 CF3M
7	Packing	PTFE
6	Upper Shaft	ASTM A564 630
5	Disc	ASYM A351 CF3M
4	Pin	ASTM A182 F316L
3	Lower Shaft	ASTM A564 630
2	Body	ASYM A351 CF3M
1	Lower Cover	ASTM A182 F316L
No	Parts Name	Parts Material

Drawing NO:		BUTTERFLY VALVE	
D043F-150LB		150LB	
DRAWING BY	CHECKED BY	APPROVED BY	Date
D.Y.Z.	M.Z.H.	M.Z.H.	2021.05.12

NPS	DN	L	ϕD	$\phi D1$	$\phi D2$	C	f	$n-\phi d$	4-M
48"	1200	470	$\phi 1510$	$\phi 1422.4$	$\phi 1359$	108.4	2	40- $\phi 42$	4-M39